



Thinking in solutions

Milling Cutter Bodies

Tooling systems and application consulting for the milling of complex 2.5 and 3D geometries



The New Catalog of Indexable Insert Systems from Pokolm

Dear customer,

This catalog provides you will full documentation on the current indexable insert system product range available from Pokolm.

The POKOLM catalog is just as well-designed as our tooling systems, since it is structured primarily according to the various usage types. Even the product overview clearly shows which types of machining and which material groups the individual cutter types can be used for, and which sizes and connection types are available.

Another user-friendly feature is that matching cutting inserts, accessories, and cutting and expanded application data are provided directly after the individual cutter types - this eliminates the need to search for this information and reduces work time. A new feature in this catalog is that information on the speeds for different cutting materials is even more detailed than in previous editions.

In addition to our proven series, the product portfolio also lists all new developments. This ensures that you always find the optimal tool system in premium quality for your specific application. Our highly trained application engineers are also happy to assist you in developing optimal, customized solutions and concepts.

We are happy to be of service and look forward to hearing from you!

Your Pokolm team

Benefit from our track record of success

Improving means always reflecting on the competition as well as on our own products and services, identifying potential areas of optimization, and above all developing innovations that represent true progress and advancement. In milling technology, lighter weight, significantly faster machines result in fundamental changes that make new cutters for higher feed rates essential, with a much lower depth of cut closer to the contour. Our company founder, F.-J. Pokolm, helped shape this key step in the development of milling cutter bodies, with a wide range of innovations that are now considered standard. Today, for instance, milling cutter bodies and cutting inserts in metric dimensions simplify calculations of relevant values, when compared to previously used inch measurements. The embedded insert seat is another Pokolm innovation that can be traced back to the spirit of invention and practical experience of the company's founder. The patented **DUOPLUG®** system offers significantly better holding forces and the highest concentricity in the industry, for a perfect screw-shrink connection between the tool and arbor. One current milestone in milling technology are **SPINWORX®** round plate routers with self-rotating cutting inserts.

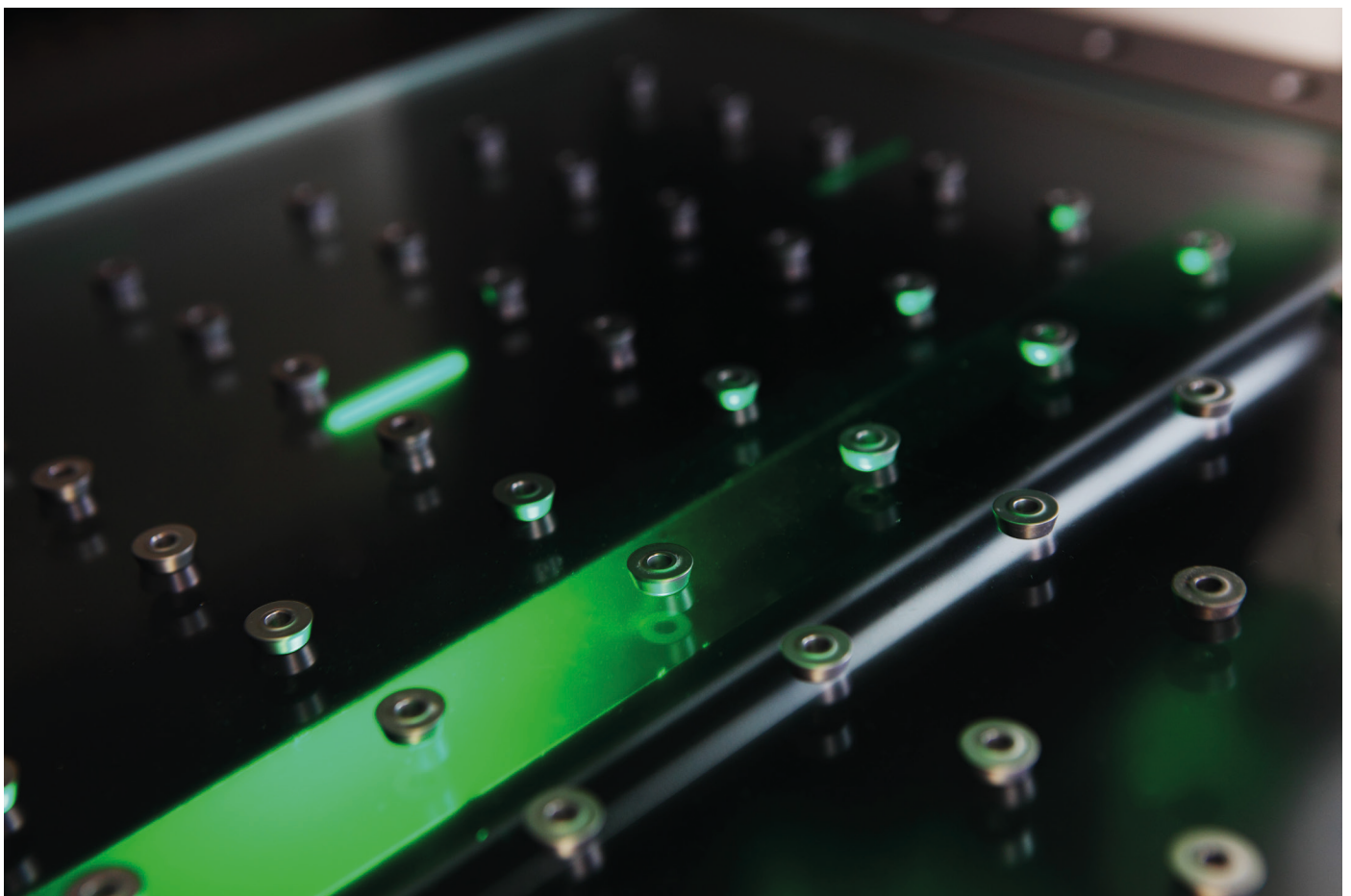

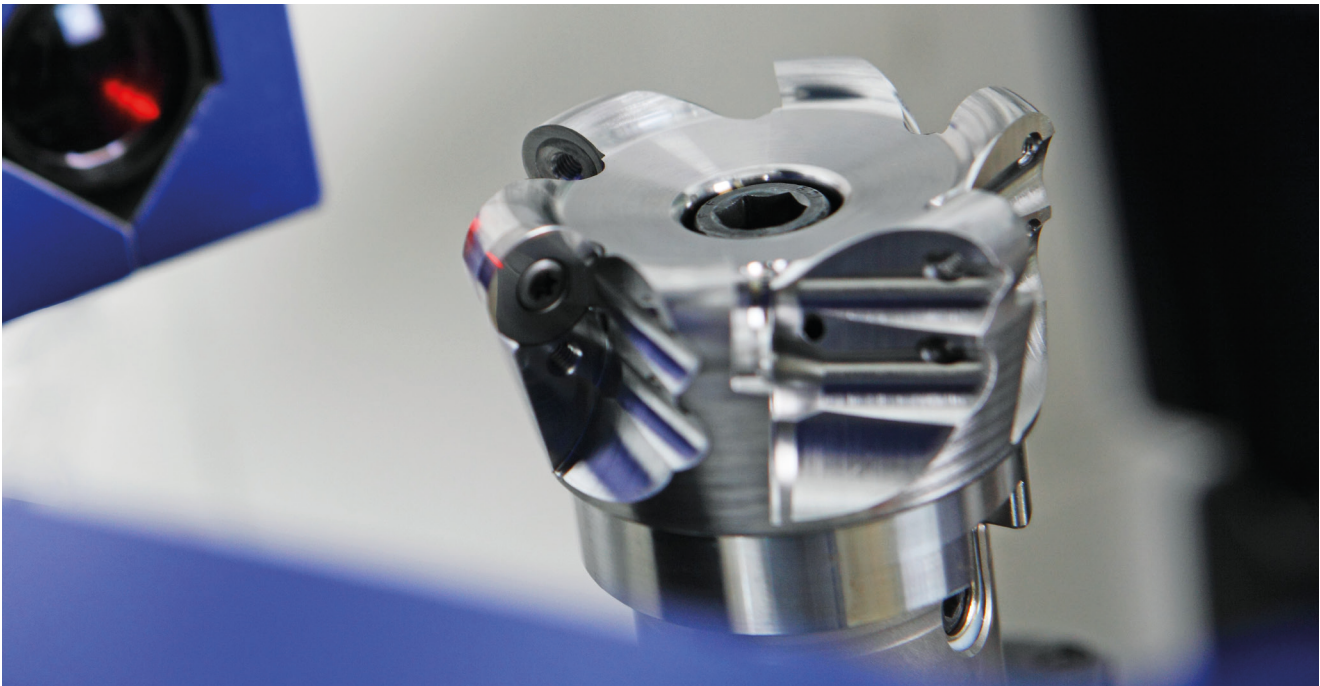

At the same time, the **SPINWORX®** tool system, which includes cutter bodies, cutting inserts, and retaining pins, clearly shows how perfectly Pokolm components are designed to work together – the result of many years of experience and wide-ranging expertise.

In addition, the highest commitment to quality and precision in development and series production, both in-house and by our suppliers, serves as an essential foundation for this success.

Successful practitioners choose premium tools from Pokolm – a choice that pays. Our tools offer Pokolm customers a key competitive advantage, thanks to the combination of excellent products and outstanding consulting from our technical sales force, fully and specifically tailored to each individual customer.



THINKING IN SOLUTIONS

Food technology



Medical technology



Tool/mold construction



Turbine construction



 **pokolm**

Airplane construction



Energy technology



Mechanical engineering



Individual designs for any application

From intricate medical technology to high-powered racing applications – our services are used in a wide range of different industries. The demands placed on our products are as diverse as they are challenging. But they all have one thing in common: the highest level of precision, quality, and expertise is always essential. It does not matter whether we are producing huge components for aviation or a highly specialized tool for the woodworking industry.

With such a wide variety of products, direct contact with our customers is essential. This is the only way we can understand precisely what specific challenges are at play. Our highly trained technical sales representatives can often provide assistance on site, and address individual requirements flexibly with custom solutions. This kind of service is what makes us experts in our industry.

Process optimization, guaranteed

Standing still is a step backwards. That is why we are continuously developing our product portfolio. This is the only way we can remain a technological leader in the field. It is also the only way you can benefit from our innovations and patents, to secure your competitive advantage for the long term.



DUOPLUG®, SPINWORX® and other patents

Order and info hotline

 Pokolm Frästechnik GmbH & Co. KG



+49 5247 9361-0



info@pokolm.com



7 :30 AM - 6:00 PM (weekdays)



Order before 5:00 PM
for same-day shipping!



The new customer portal

More service. More convenience. Around the clock.

- Place orders with just a few clicks
- Submit inquiries digitally and easily
- Available 24/7 – access anytime



pokolm.com/portal



Diversity in the highest quality

The intelligent POKOLM tool system offers the optimal tool for any need – from arbors to milling cutter bodies or solid carbide cutters to cutting inserts in various designs, grades, and coatings. Competent consulting by our technical field service, first class service, a comprehensive range of accessories and training courses for our customers in the POKOLM Academy create a unique, full-service concept. With all these services and more, we support your long-term success throughout every step of the process chain.

Milling cutter bodies for every application

Face mills, e.g.

- ⑥ MIRROWORX® M
- ⑧ MIRROWORX® S
- ⑩ PLANWORX®

Copy end mill, e.g.

- ④ SPINWORX®
- ⑫ ROUND INSERT CUTTERS

Cutters for NF machining, e.g.

- ⑮ VDGT

Rhombic milling cutters, e.g.

- ① FINWORX®
- ⑭ XDHW / XDHT

Sharp corner and slot milling cutters, e.g.

- ② SLOTWORX® L
- ⑦ SLOTWORX® VF
- ⑯ QUADWORX® XL

Ball nose/toric end mills, e.g.

- ⑨ WAVEWORX®
- ⑪ UNIWORX®

High-feed cutters, e.g.

- ③ SLOTWORX HP® M
- ⑤ SLOTWORX HP® S
- ⑬ UNIWORX® PLUS
- ⑰ QUADWORX® XL

The complete spectrum of Pokolm products for cutting technology



Milling cutter bodies



Arbor and adapter systems



Accessories



Indexable inserts



Spindle systems
Shrink technology

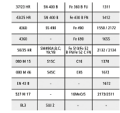

Detailed technical expertise



Solid carbide end mills



Specialty products



Qualified service

THINKING IN SOLUTIONS

poko m

Overview of milling cutter bodies



Table of contents

	Page
Product overview	12
Face mills	25 - 33
Sharp corner and slot milling cutters	35 - 61
Copy end mills	63 - 121
Rhombic milling cutters	123 - 135
Cutters for NF machining	137 - 147
Ball and toric end mills	149 - 157
Bull end / high feed cutters	159 - 196
Accessories	197 - 201
Technical information	202 - 217
Assembly instructions	218 - 222
Order form	223
Index	224 - 229
Notes	230 - 233
Quick finder	234

Milling cutter bodies - Product overview

Cutters	Connection type	Page	Machining types	Material group ISO 513															
				P	M	K	N	S	H										
Face mills																			
PLANWORX®		25																	
Ø 40 - 250 mm		26																	
MIRROWORX®		29																	
Size S - Ø 16 - 35 mm		30																	
Size M - Ø 42 - 100 mm		32																	
Sharp corner and slot milling cutters - k90°																			
SLOTWORX®		35																	
Size M - Ø 16 - 52 mm		38																	
Size L - Ø 25 - 100 mm		42																	
QUADWORX® -k90°		47																	
Size XL Ø 32 - 100 mm		48																	
SLOTWORX® VF		51																	
Size M - Ø 16 - 42 mm		52																	
SQUAREWORX®		55																	
Ø 25 - 66 mm K=90°		57																	
Ø 16 - 63 mm K=45°		58																	
SQUAREWORX® Porcupine cutter		59																	
Size M - Ø 40 - 66 mm K=90°		59																	
Copy end mills - k0°-90°																			
SPINWORX®		63																	
r3.5 - Ø 16 - 35 mm, 7° positive		65																	
r5 - Ø 20 - 52 mm, 7° positive		68																	
r6 - Ø 24 - 100 mm, 7° positive		72																	
r8 - Ø 32 - 125 mm, 7° positive		76																	
r10 - Ø 100 - 160 mm, 7° positive		80																	
Round insert cutters																			
r3.5 - Ø 12 - 25 mm, s		84																	
r3.5 - Ø 15 - 42 mm, s 2.38 mm		87																	
r5 - Ø 20 - 42 mm, neutral		91																	
r5 - Ø 25 - 52 mm, 7° positive		96																	
r5 - Ø 20 - 35 mm, CBN, neutral		101																	
r6 - Ø 42 - 80 mm, 7° positive, shim		103																	
r6 - Ø 24 - 80 mm, neutral, 7° positive		107																	
r8 - Ø 52 - 100 mm, 7° positive, shim		112																	
r8 - Ø 32 - 160 mm, neutral, 7° positive		115																	
r10 - Ø 40 - 160 mm, neutral, 7° positive		119																	

Machining types

- Angled plunging
- Chamfer milling
- Face milling
- Helical milling
- Vertical plunging
- Slot milling
- Sharp corner milling
- Copy end milling
- Pocket milling

Connection types

- Shell-type milling cutter body
- DUOPLUG®
- Threaded shank end mill body
- Weld on surface
- Plain shank

Cutters	Connection type	Page	Machining types	Material group ISO 513											
				P	M	K	N	S	H						
Rhombic milling cutter - k95°															
FINWORX®		123													
Ø 16 - 42 mm r1		124		▽	▽	▽	▽	▽	-	▽					
XDHW 06 XDHT 06		127													
Ø 16 - 42 mm r1		128		▽	▽	▽	▽	▽	-	▽					
Ø 16 - 35 mm r2		131		▽	▽	▽	▽	▽	-	▽					
XDHW 10		133													
Ø 25 - 80 mm r1		133		▽	▽	▽	▽	▽	-	▽					
Cutters for NF machining															
VDGT - r1		137													
Ø 15 - 42 mm r1		138		-	-	-	-	-	▽	-	-	-	-	-	-
Ø 15 - 42 mm r1		140		-	-	-	-	-	▽	-	-	-	-	-	-
VCGT - r3		143													
Ø 32 - 80 mm r3		144		-	-	-	-	-	▽	-	-	-	-	-	-
Ø 32 - 125 mm r3		146		-	-	-	-	-	▽	-	-	-	-	-	-
Ball nose / toric end mills															
WAVEWORX®		149													
Ø 16 mm - 32 mm		150		-	-	-	-	-	▽	-	-	-	-	-	-
UNIWORX®		153													
Ø 8 mm - 20 mm		154		-	-	-	-	-	▽	▽	▽	▽	▽	-	▽
Bull end / high feed cutters															
UNIWORX® PLUS		159													
diam 10 - 20 mm - r 0.5 r 1.0		160		▽	▽	▽	▽	▽	▽	▽	▽	▽	▽	▽	▽
Ø 10 - 20 mm - HF		163		▽	▽	▽	▽	▽	▽	▽	▽	▽	▽	▽	▽
High feed cutter															
SLOTWORX® HP		167													
HP Size S - Ø 10 - 32 mm		168		▽	▽	▽	▽	▽	▽	▽	▽	▽	▽	▽	▽
HP size M - Ø 16 - 52 mm		172		▽	-	▽	-	▽	-	▽	-	▽	-	▽	-
SLOTWORX® K15° (HSC)		175													
HF size M - Ø 16 - 52 mm		176		▽	▽	▽	▽	▽	▽	▽	▽	▽	▽	▽	▽
FOURWORX® HP		181													
Size S - Ø 16 - 42 mm		182		▽	▽	▽	▽	▽	▽	▽	▽	▽	▽	▽	▽
QUADWORX®		187													
Size M - Ø 22 - 52 mm		188		▽	▽	▽	▽	▽	▽	▽	▽	▽	▽	▽	▽
Size L - Ø 35 - 80 mm		191		▽	▽	▽	▽	▽	▽	▽	▽	▽	▽	▽	▽
Size XL - Ø 32 - 100 mm		194		▽	▽	▽	▽	▽	▽	▽	▽	▽	▽	▽	▽

<2/2

Primary application

Roughing
 Pre-finishing
 Finishing

Secondary application

Roughing
 Pre-finishing
 Finishing

Efficiency for higher profitability

The comprehensive analysis and individual consultation of our highly qualified technical field service are focused fully on your specific process application – and always with one goal in mind: To lower costs and increase productivity.

Our goal: Lower costs

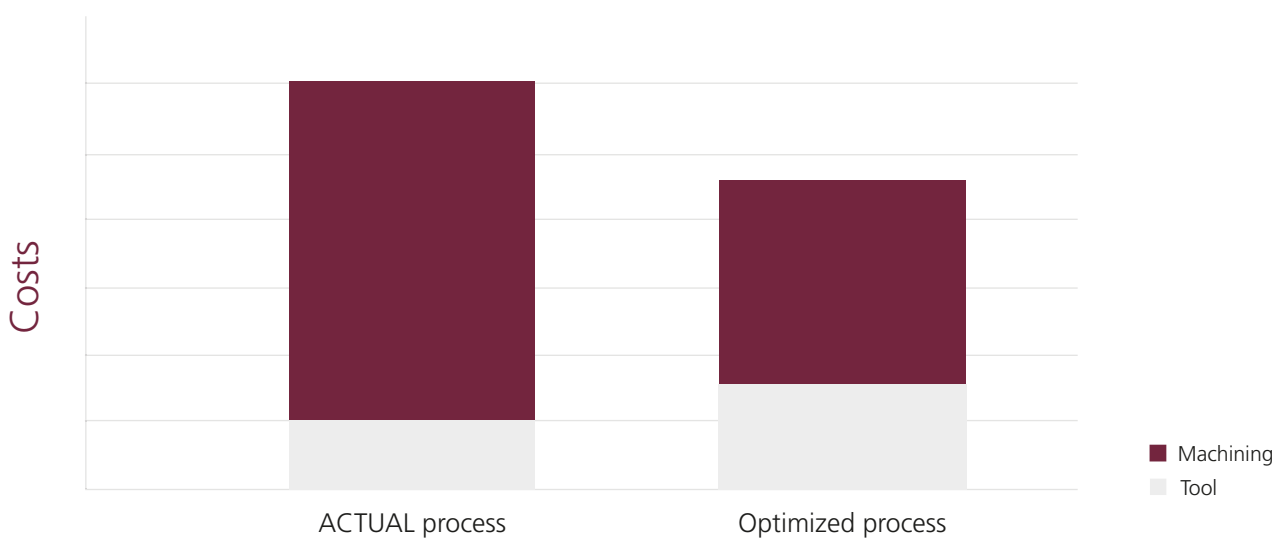

Our approach: Process optimization

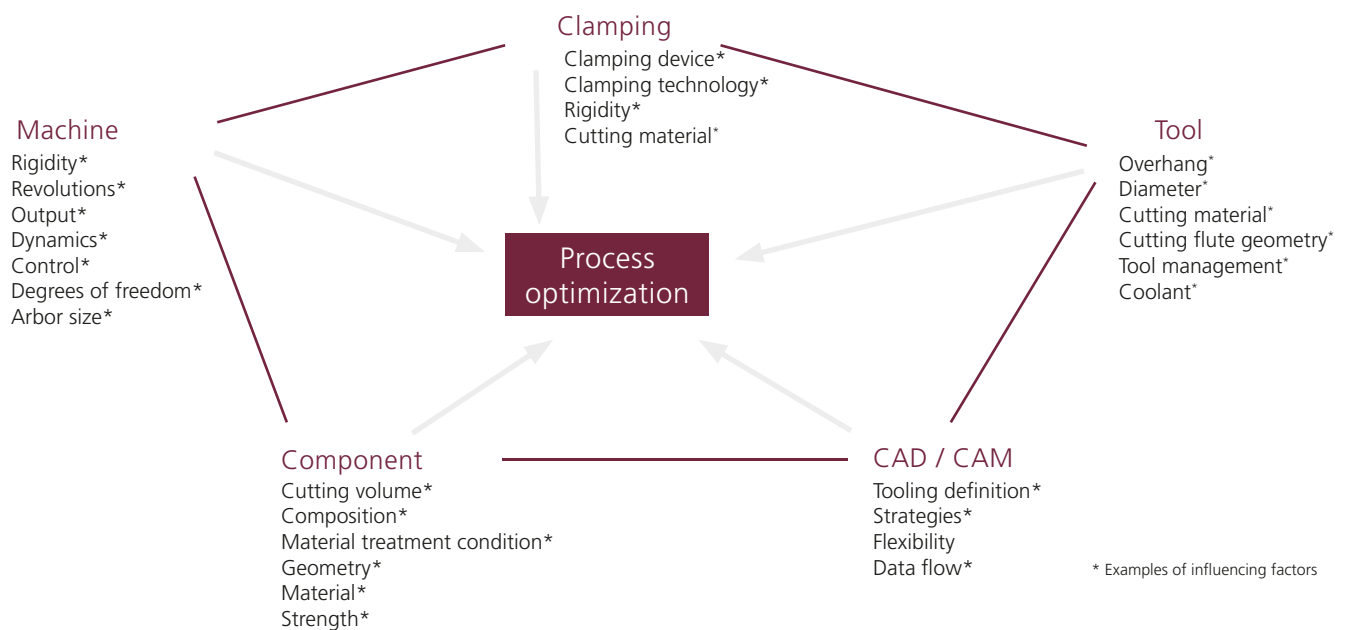

Your center for expertise: the Pokolm Academy

First class products are one thing. But the foundation for creating tooling systems that are more profitable, faster and more powerful is: KNOWLEDGE

That is why we created the POKOLM Academy for you. There, the focus is on actively finding new solutions, transmitting knowledge, and securing your competitive advantage for the long term.

Ongoing education is key to mastering the challenges of the market.

At the POKOLM Academy, we offer you professional workshops, seminars, and training sessions that convey a deep level of product expertise. This is an important key for your success.



Added value through knowledge

From metallurgy to tools and their coatings, to milling strategies for CNC cutters and programmers – proven experts and professionals present their expertise in the Academy, giving you and your employees a decisive advantage in knowledge over the competition.

The Pokolm tool system

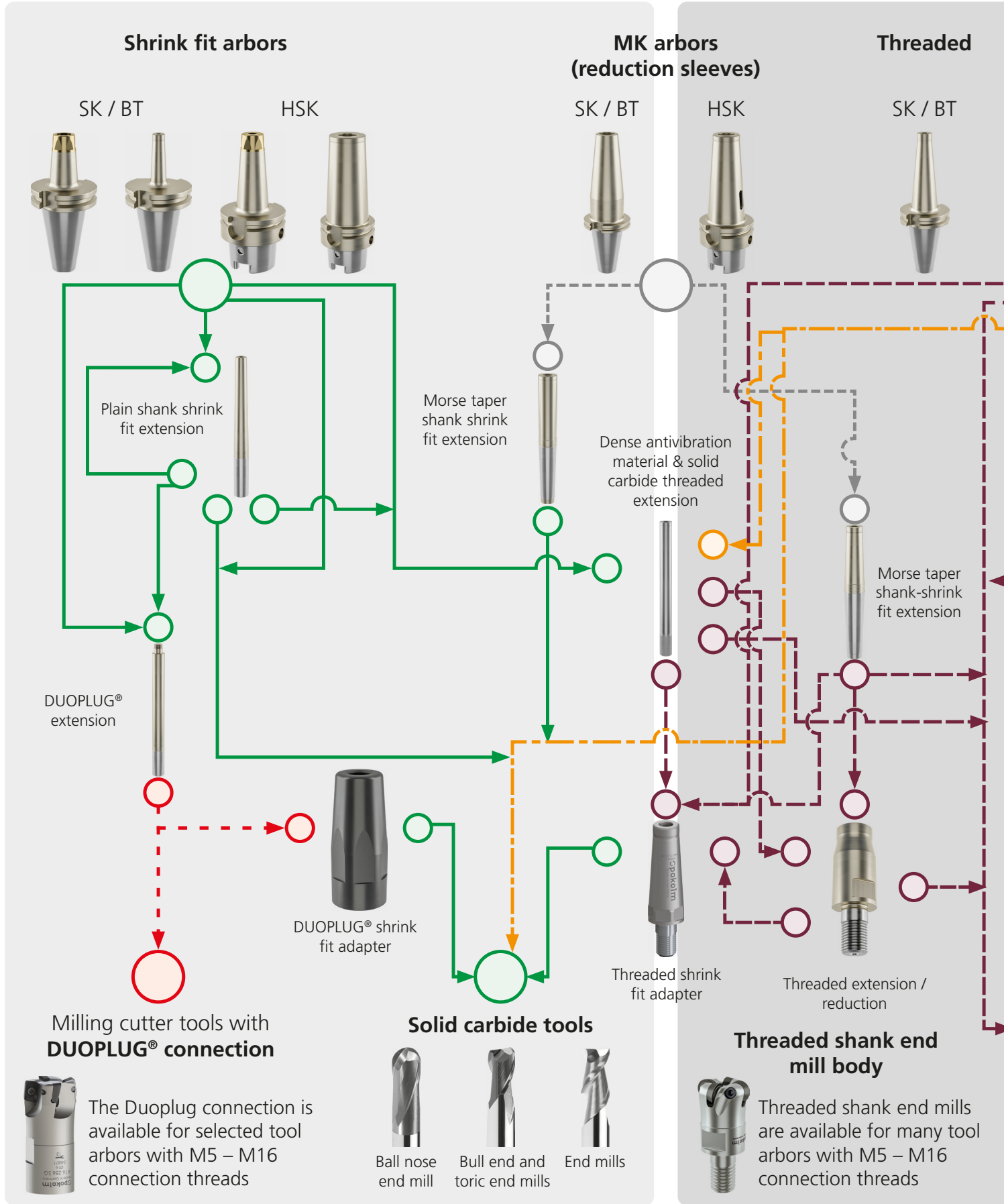

——— Shrink fit connection
- - - - - Morse taper connection
- - - - - Threaded connection

- · - · - · Shell-type connection
- - - - - ER collet connection
- · - · - · DuoPlug®-connection

Arbors

HSK



ER collet arbors

SK / BT



HSK



Arbor for shell type milling cutters

SK / BT



HSK



Flat contact surface

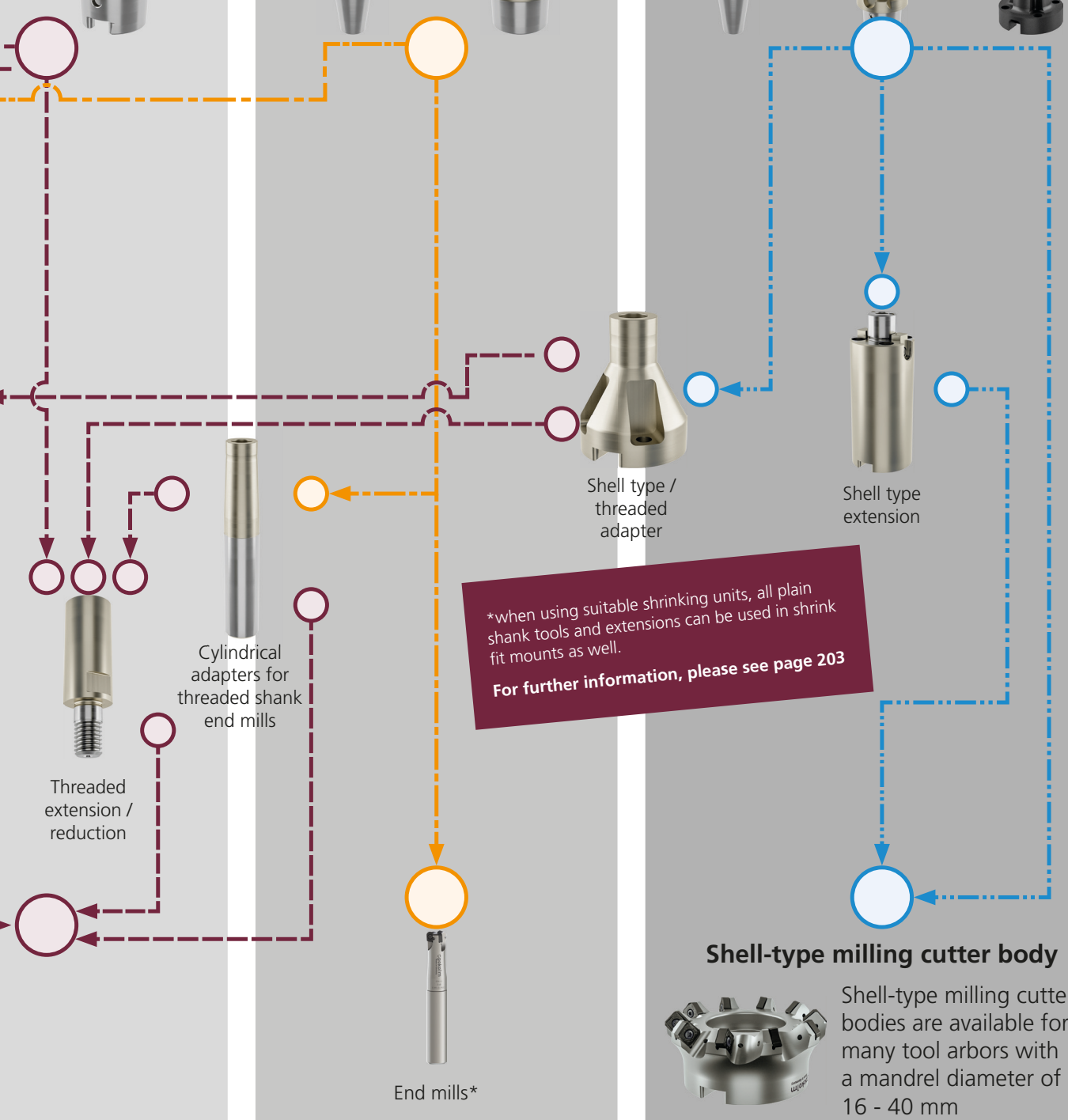

*when using suitable shrinking units, all plain shank tools and extensions can be used in shrink fit mounts as well.
For further information, please see page 203

Shell-type milling cutter body

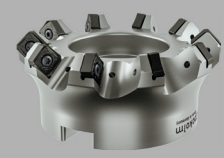

Shell-type milling cutter bodies are available for many tool arbors with a mandrel diameter of 16 - 40 mm

Technology comparison

Threaded connection vs. Pokolm DuoPlug® connection

What sets the systems apart:

Pokolm threaded connection – the powerful standard

Pokolm threaded connection

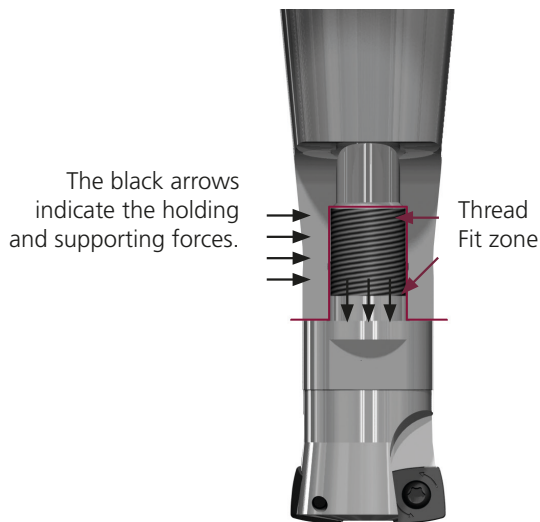

Benefits

- no undercut, avoiding a predetermined breaking point
- high-precision fit zone, and high-precision contact surface
- higher tensile strength and thermal stability by using custom materials with specialized hard coating
- for hundreds of tool changes
- optimized chamfer design on the milling arbors

Your benefits

- universal use for roughing and finishing operations
- high durability and red hardness
- lower tool costs thanks to longer service life
- significant increase in stability due to larger contact surface

Ideal applications

- standard option for milling operations in short and medium machining depths
- specifically for deep machining situations without vertical walls

The standard threaded connection is produced with the highest tolerances using state of the art technology. Structural optimizations of the tool and arbor significantly improve the performance capabilities of the Pokolm thread connection system.

The patented DuoPlug® system – the perfect improvement

Pokolm-DuoPlug® = shrink grip and screw fit

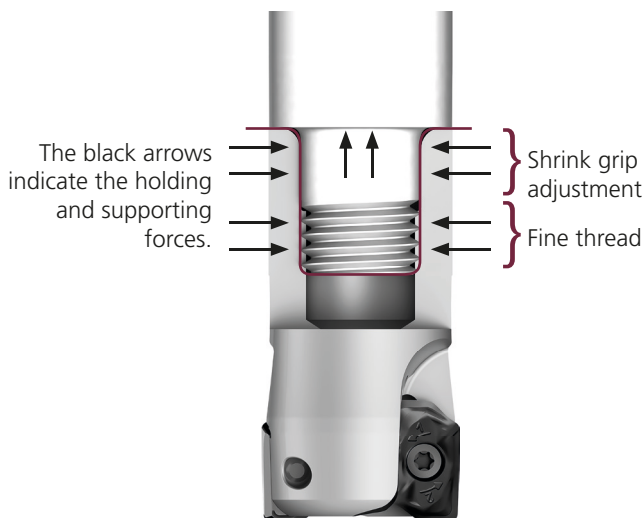

Benefits

- highest precision and concentricity
- optimal stability
- absolutely backlash-free tolerance fit seat thanks to shrink grip connection
- extremely precise and reproducible tool seat
- significantly better holding force than common threaded systems
- higher tensile strength and thermal stability by using custom materials with specialized hard coating

Your benefits

- increased process reliability
- longer tool life
- significant reduction in vibrations with long overhangs
- facilitates the highest precision in finishing operations
- high availability for the tool system and improved process reliability
- improved performance in roughing operations
- high durability and red hardness

Ideal applications

- high-precision finishing operations
- finishing and roughing work with long overhangs
- machining situations on vertical walls thanks to extremely narrow arbor system

The Pokolm **DuoPlug®** system offers optimal stability with the highest precision and concentricity. As a supplement to common screw-fitting tools, the holding forces between the tool and arbor system act over the full surface of the entire shrink grip connection, and large portions of the shrink grip thread. See the assembling instructions for the **DuoPlug®** in the "Technical Data" section for further information.

It's a fact:

DuoPlug® perfects threaded connections with significantly better holding force and the highest precision, at extremely narrow dimensions.

Milling cutter bodies



Well embedded: For a variety of cutting advantages.

In milling cutter body systems from POKOLM, precisely tailored tools and indexable inserts complement one another in a comprehensive product range that covers well over 90% of machining situations, in particular in tool and mold building.



The specially developed, patented insert seat provides optimal hold for cutting inserts in the tool arbor, facilitating high feed rates and longer tool lives through outstanding stability.



We offer specially designed tools with unique indexable insert geometries and an optimized smooth coating for machining non-ferrous metals and non-metals.



Tools with neutral or different positive adjustments offer optimal machining conditions for a wide range of different materials and machines.



State of the art technology: Almost all tools in the Pokolm tool system are equipped with an internal coolant supply.



The patented Pokolm DuoPlug® connection system eliminates looseness to the arbor and achieves high-precision surfaces in finishing, combined with high holding forces for requirements at extreme cutting performance in roughing.



2-point contact milling tools can be used with a plunging angle of 90°.



Safety in roughing. The shim acts both as protection and to dampen vibrations. This product feature also delivers process reliability and has a positive influence on smooth running performance.



Optimized geometries, carbide grades, specially developed for the properties of rust, acid, and heat resistant stainless steels, guarantee outstanding cutting results.

For more information on the special features of individual Pokolm tool systems, please see the following pages.

Technology overview

Milling cutter bodies

Improved economic efficiency

7 increments for round indexable inserts and numerous geometries and sizes – combined with many different axial angles in the cutter body – offer optimal conditions for almost any conceivable application.

Different axial angles for every requirement:



A negative basic shape delivers improved tooth stability and maximum smooth-running performance



A neutral geometry is outstanding for hard machining, and delivers maximum contour precision



Positive arbors, combined with cutting inserts with a hollow cavity, are highly suitable for less powerful machines and RSH materials



Technology overview

Milling cutter bodies

Optimal force distribution

The patented embedding of the indexable inserts in the carrier tool optimally dissipates the axial and radial cutting forces that occur, since the cutting insert is not held only by the Torx screw, but instead is supported in the carrier tool. This means the cutting pressure does not act solely on the cutting insert, but is also conducted into the milling body.

Compared to open insert seats, embedding the cutting insert also allows for stronger teeth, thereby significantly improving the stability of the tools. This makes it possible to achieve higher tool lives and feed rates. Additional double clamps also offer excellent hold under extreme conditions.

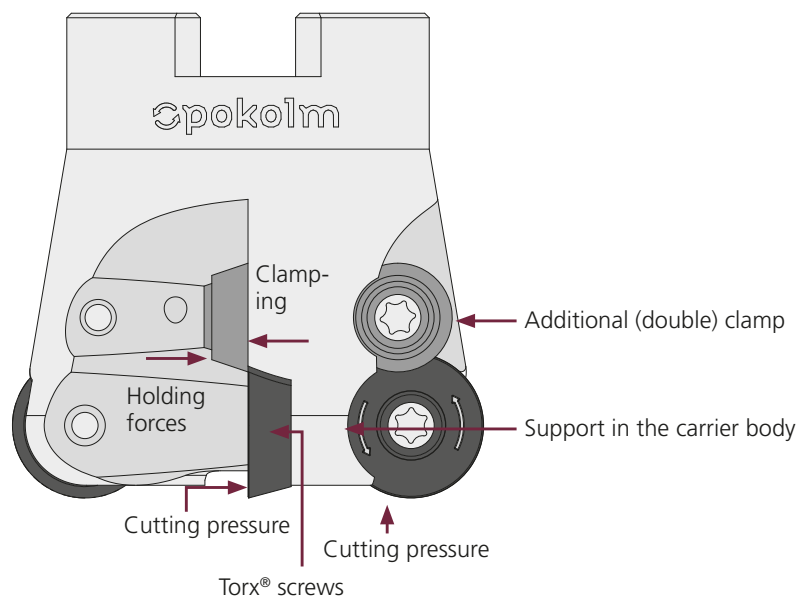

Reduced wear

The chip rooms are specially designed to achieve easy machining processes and save material. Precisely matched coolant channels in the tools and arbors deliver the coolant directly to the cutting flute, even under difficult cutting conditions.

Specialized materials and special hard coatings offer higher tensile strength and thermal stability, and make Pokolm tools and arbor systems unbeatable in terms of durability and service life.

Indexable inserts

The complete product range

Pokolm's product portfolio stands out for its broad diversity and well-designed range of indexable inserts.

Perfectly tailored to our tool system, with a large selection of grades, geometries, and different applications, they provide the optimal solution for any application:

Diameters from 5-20 mm, different shapes, materials, and coatings allow for any custom combination alongside a wide range of carrier tools and patented embedding.

All Pokolm indexable inserts are based on tested, practical applications from our customers, and are developed continuously in response to new challenges.

This ongoing and innovative development process, and intensive cooperation with our suppliers and coating partners, ensures we always supply state of the art quality.

THINKING IN SOLUTIONS



Face mills

PLANWORX® face mills

Highly economical with great machining depth and fantastic smooth-running design

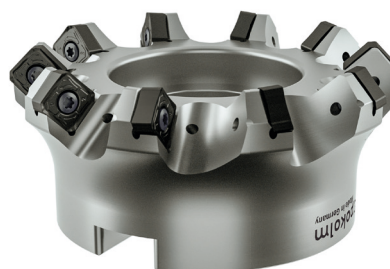

Properties

- negative, and therefore extremely stable base form
- eight reliably usable cutting flutes
- easy cutting thanks to highly positive indexable insert geometry
- uneven division for less vibration
- coolant bore for media up to tool diameter 125 mm
- outstanding smooth-running design
- adjustment angle Kappa ~45°

Sizes	Page
Ø 40 - 250 mm	26

Machining types

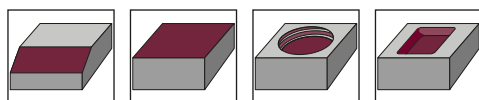

Connection types

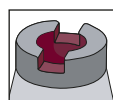

Practical video
PLANWORX® in
1.0570 /
1015 / St 52 - 3



Cutting materials

Coating grade	ISO application						Application data (mm)		Cutting flute length	Thickness	Radius
	P	M	K	N	S	H	f _z	a _p	l (mm)	s (mm)	r (mm)
P40 PVSR	▽	-	-	-	-	-	0.08 - 0.55	0.1 - 6.0	13	5.4	0.8
K10 PVTi	-	-	▽	-	-	-	0.1 - 0.55	0.1 - 6.0	13	5.4	0.8
M40 PVST	-	▽	-	-	▽	-	0.08 - 0.3	0.1 - 4.0	13	5.4	0.8

PLANWORX®

Ø 40 - 250 mm



Milling cutter bodies	Part no.	d ₁	l	r	l ₃	l ₂	d	d ₂	d ₃	z
-----------------------	----------	----------------	---	---	----------------	----------------	---	----------------	----------------	---

Shell-type milling cutter body										
	4 40 331	40	13	0.8	42	6.7	53.5	22	40	4
	5 50 331	50	13	0.8	52	6.7	63.5	27	48	5
	6 63 331	63	13	0.8	52	6.7	76.5	27	60	6
	8 80 331	80	13	0.8	52	6.7	93.5	32	70	8
	10 100 331	100	13	0.8	52	6.7	113.5	40	90	10
	12 125 331	125	13	0.8	52	6.7	138.5	40	90	12
	14 160 331*	160	13	0.8	52	6.7	173.5	40	120	14
	16 200 331*	200	13	0.8	52	6.7	213.5	60	160	16
	20 250 331*	250	13	0.8	52	6.7	263.5	60	160	20

The accessories shown here must be used for all sizes!	Accessories	40 505 P	Torx screw	> Page 197
		15 500 P	Torx wrench (Torx Plus)	> Page 198
		SG25	TORQUE CliX-S grip	> Page 199
		TG55	TORQUE CliX-T grip	> Page 199
		DM38	Torque adapter 3.8 Nm	> Page 199
		TP15-R	6-pack bits (Torx Plus)	> Page 200

Indexable inserts	Part no.	DIN designation	Quality	Coating	l	s	r	M
-------------------	----------	-----------------	---------	---------	---	---	---	---

	05 31 842	SNMX 135408 ER	P40	PVSR	13	5.4	0.8	M 4
	05 31 862	SNMX 135408 ER	K10	PVTi	13	5.4	0.8	M 4
	05 31 8096	SNMX 135408 ER	M40	PVST	13	5.4	0.8	M 4

Application data (fz / ap)

Material							
Coating grade	Feed rate/Depth of cut	Steel	Stainless steel	Cast iron	NF metal and non-metals	High-temperature resistant alloys	Hardened materials
P40 PVSR	f _z (mm) a _p (mm)	0.08-0.55 0.1-6	-	-	-	-	-
K10 PVTi	f _z (mm) a _p (mm)	-	-	0.1-0.55 0.1-6	-	-	-
M40 PVST	f _z (mm) a _p (mm)	-	0.08-0.3 0.1-4	-	-	0.08-0.2 0.1-3	-

*Tools do not have an internal coolant supply

Spindle speed (V_c in m/min)

Material							
Coating grade	Application	Steel	Stainless steel	Cast iron	NF metal and non-metals	High-temperature resistant alloys	Hardened materials
P40 PVSR	Roughing Semi-Finish Finish	▼100 200 300 ▼100 200 300 -	-	-	-	-	-
K10 PVTi	Roughing Semi-Finish Finish	-	-	▼150 175 200 ▼150 175 200 ▼150 200 250	-	-	-
M40 PVST	Roughing Semi-Finish Finish	-	▼80 130 180 ▼100 155 210 ▼120 185 250	-	-	▼30 55 80 ▼40 65 90 ▼60 90 120	-

Expanded application data

Full axial plunge		Full oblique plunge			Circular milling		
Arbor Ø d1	X_{max} mm	Arbor Ø d1	α°	y mm	Arbor Ø d1	D_{min} mm	D_{max} mm
40-125	4	40	<11	29.5	40	89.5	93.5
160-250	-	50	<8	39.5	50	109.5	113.5
		63	<6.5	52.5	63	135.5	139.5
		80	<4	69.5	80	169.5	173.5
		100	<3.5	89.5	100	209.5	213.5
		125	<2.5	114.5	125	259.5	263.5
		160	<2	149.5	160	329.5	333.5
		200	<1	189.5	200	409.5	413.5
		250	<1	239.5	250	509.5	513.5



MIRROWORX®
Finishing face mills

Mirroworx
Made in Germany

MIRROWORX® Finishing face mills

Mill instead of grind – smooth surfaces with outstanding affordability



Properties

- surface qualities of $R_z < 2.5 \mu\text{m}$, completely eliminating the grinding process
- unique smooth-running design
- fine adjustment regulates axial run-out down to the μm
- also suitable for unstable components
- all three cutting flutes can be used reliably

Sizes	Page
S: $\varnothing 16 - 35 \text{ mm}$	30
M: $\varnothing 42 - 100 \text{ mm}$	32

Practical video
MIRROWORX®
in 1.2312



Machining types

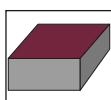

Connection types

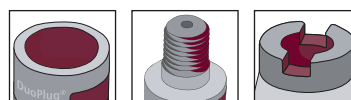

Cutting materials

Coating grade	ISO application						Application data (mm)		Cutting flute length	Thickness	Radius
	P	M	K	N	S	H	f_z	a_p	l (mm)	s (mm)	r (mm)
S: HSC 05 PVTi HSC 05 PVTiH	▼	▼	▼	▼	▼	▼	0.1 - 1.5	0.02 - 0.2	8.2	3	0.5
M: HSC 05 PVTi	▼	▼	▼	▼	▼	▼	0.2 - 2.0	0.05 - 0.25	14.32	4	–

MIRROWORX®

Size S - Ø 16 - 35 mm



Characteristics:

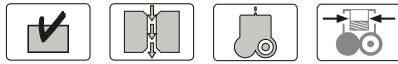

Milling cutter bodies	Part no.	d ₁	l	r	l ₃	l ₂	l ₁	d ₂	d ₃	z
-----------------------	----------	----------------	---	---	----------------	----------------	----------------	----------------	----------------	---

DuoPlug®

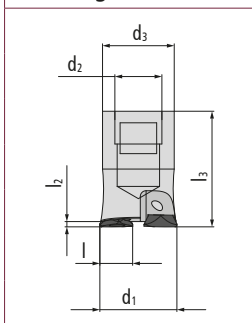

1 16 283 SG	16	8.2	0.5	25	1	–	M 10	15	1
2 20 283 SG	20	8.2	0.5	27	1	–	M 12	18.6	2
2 25 283 SG	25	8.2	0.5	32	1	–	M 16	23.5	2

Threaded shank end mill body

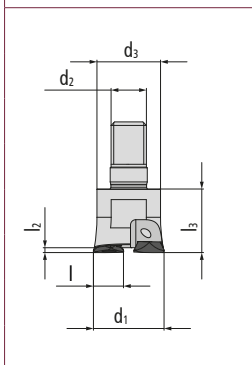

1 16 283	16	8.2	0.5	18	1	–	M 8	13.8	1
2 20 283	20	8.2	0.5	18	1	–	M 10	18	2
2 25 283	25	8.2	0.5	22.5	1	–	M 12	21	2
2 30 283	30	8.2	0.5	28	1	–	M 12	29	2
2 32 283	32	8.2	0.5	28	1	–	M 16	29	2
2 35 283	35	8.2	0.5	28	1	–	M 16	29	2

The accessories shown here must be used for all sizes!

Accessories

25 500	Torx screw	> Page 197
07 500	Torx wrench	> Page 198
SG25	TORQUE CliX-S grip	> Page 199
TG55	TORQUE CliX-T grip	> Page 199
DM09	Torque adapter 0.9 Nm	> Page 199
T07-R	6-pack bits (Torx)	> Page 200

Indexable inserts

Part no.	DIN designation	Quality	Coating	l	s	r	M
----------	-----------------	---------	---------	---	---	---	---

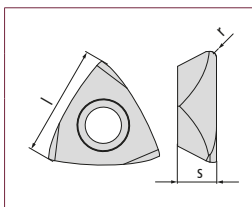

03 83 835	TOHX 063005 ER	HSC 05	PVTi	8.2	3	0.5	M 2.5
03 83 836	TOHX 063005 ER	HSC 05	PVTiH	8.2	3	0.5	M 2.5

Application data (fz / ap)

Material							
Coating grade	Feed rate/ Depth of cut	Steel	Stainless steel	Cast iron	NF metal and non-metals	High-temperature resistant alloys	Hardened materials
HSC 05 PVTi	f _z (mm) a _p (mm)	0.2-1 0.02-0.15	0.1-0.8 0.02-0.1	0.2-1 0.02-0.15	0.1-1.5 0.02-0.2	0.1-0.7 0.02-0.1	0.1-1 0.02-0.15
HSC 05 PVTiH	f _z (mm) a _p (mm)	0.2-1 0.02-0.15	0.1-0.8 0.02-0.1	0.2-1 0.02-0.15	0.1-1.5 0.02-0.2	0.1-0.7 0.02-0.1	0.1-1 0.02-0.15

Spindle speed (Vc in m/min)

Material							
Coating grade	Application	Steel	Stainless steel	Cast iron	NF metal and non-metals	High-temperature resistant alloys	Hardened materials
HSC 05 PVTi	Roughing	–	–	–	–	–	–
	Semi-Finish	–	–	–	–	–	–
	Finish	▼150 275 400	▼100 150 200	▼200 275 350	▼100 450 800	▼40 70 100	▼100 175 250
HSC 05 PVTiH	Roughing	–	–	–	–	–	–
	Semi-Finish	–	–	–	–	–	–
	Finish	▼150 275 400	▼100 150 200	▼200 275 350	▼200 500 800	▼40 70 100	▼100 175 250

MIRROWORX®

Size M - Ø 42 - 100 mm

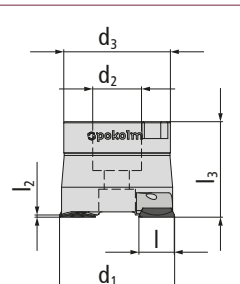

Milling cutter bodies	Part no.	d ₁	l	r	l ₃	l ₂	l ₁	d ₂	d ₃	z
-----------------------	----------	----------------	---	---	----------------	----------------	----------------	----------------	----------------	---

Shell-type milling cutter body											
	2 42 384	42	14.32	–	43	1	–	16	35	2	
	Accessories	GWSTPS8ISK		Setscrew with hexagon socket				> Page 198			
	2 52 384	52	14.32	–	43	1	–	22	48	2	
	2 66 384	66	14.32	–	53	1	–	27	60	2	
	2 80 384	80	14.32	–	53	1	–	27	60	2	
	2 100 384	100	14.32	–	53	1	–	32	70	2	

The accessories shown here must be used for all sizes!	Accessories	35 500 L	Torx screw	> Page 197
		45 500 L	Torx screw	> Page 197
		15 500	Torx wrench	> Page 198
		20 500	Torx wrench	> Page 198
		SG25	TORQUE CliX-S grip	> Page 199
		TG55	TORQUE CliX-T grip	> Page 199
		DM25	Torque adapter 2.5 Nm	> Page 199
		T15-R	6-pack bits (Torx)	> Page 200

Indexable inserts	Part no.	DIN designation	Quality	Coating	l	s	r	M
-------------------	----------	-----------------	---------	---------	---	---	---	---

	04 84 835	TEHX 16T3 ZF	HSC 05	PVTi	14.32	4	–	M 3.5
---	-----------	--------------	--------	------	-------	---	---	-------

	04 84 835 EC	TEHX 16T3 ZF	HSC 05	PVTi	14.32	4	–	M 3.5
---	--------------	--------------	--------	------	-------	---	---	-------

Application data (fz / ap)

Material							
Coating grade	Feed rate/ Depth of cut	Steel	Stainless steel	Cast iron	NF metal and non-metals	High-temperature resistant alloys	Hardened materials
HSC 05 PVTi	f _z (mm) a _p (mm)	0.5-2 0.05-0.2	0.5-1 0.05-0.1	0.5-2 0.05-0.2	0.5-2 0.05-0.25	0.2-1 0.05-0.1	0.2-1 0.05-0.1

Spindle speed (Vc in m/min)

Material							
Coating grade	Application	Steel	Stainless steel	Cast iron	NF metal and non-metals	High-temperature resistant alloys	Hardened materials
HSC 05 PVTi	Roughing Semi-Finish Finish	– – ▼ 150 275 400	– – ▼ 100 150 200	– – ▼ 200 275 350	– – ▼ 100 450 800	– – ▼ 40 70 100	– – ▼ 35 143 250

THINKING IN SOLUTIONS



Sharp corner and slot milling cutters

SLOTWORX® sharp corner and slot milling cutters

With state of the art cutting flute geometry for universal applications



Properties

- universal applications: roughing and finishing steel, aluminum, graphite, plastic, hardened materials, cast iron and stainless as well as high-temperature resistant materials
- optimized coolant flow to the cutting flute
- integrated finishing chamfer achieves outstanding surface qualities
- Bull ends of 0.4 - 5 mm

Sizes	Page
S: Ø 10 - 32 mm	36
M: Ø 16 - 52 mm	38
L: Ø 25 - 100 mm	42

Machining types

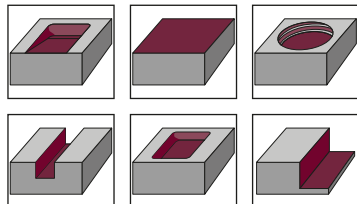

Connection types

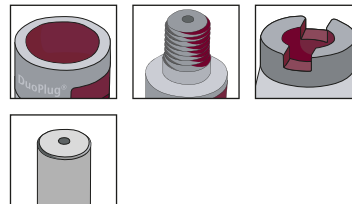

Practical video
 SLOTWORX® M / zero length
 DuoPlug SK50 / 1.2344 ESU
 48 HRC / X40CrMoV









Cutting materials

Size	ISO application						Application data (mm)		Cutting flute length	Sizes, radii (mm), qualities						
	P	M	K	N	S	H	f_z	a_p	l (mm)	0.4	0.8	1.0	2.0	3.0	4.0	5.0
HP-S	▼	▼	▼	▼	▼	▼	0.05 - 0.3	0.3 - 2.0	6.2	-	HSC05	-	-	-	-	-
M	▼	▼	▼	▼	▼	▼	0.05 - 0.35	0.1 - 9.0	10	K10	K10, HSC05, P40, M40, M35	K10, HSC05, P40, PKD, M40	K10, M40	K10, M40	K10, M40	-
L	▼	▼	▼	▼	▼	-	0.08 - 0.5	0.1 - 14	15	-	-	K10, P40, M40	K10, M40	K10, M40	K10, M40	K10, M40

SLOTWORX® K90°

SLOTWORX® - size S - Ø 10 - 32 mm



Characteristics:      

Milling cutter bodies	Part no.	d ₁	l	r	l ₃	l ₂	l ₁	d ₂	d ₃	z
-----------------------	----------	----------------	---	---	----------------	----------------	----------------	----------------	----------------	---

DuoPlug®

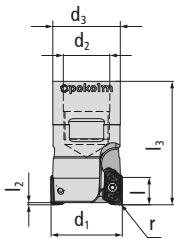

3 12 266 SG	12	6.2	0.8	28	0.7	-	M 7	10.8	3
4 16 266 SG	16	6.2	0.8	31	0.7	-	M 10	15	4
5 20 266 SG	20	6.2	0.8	33	0.7	-	M 12	18.6	5
5 25 266 SG	25	6.2	0.8	35	0.7	-	M 16	23.5	5

Threaded shank end mill body

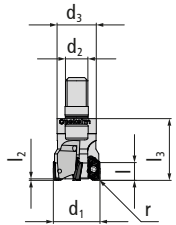

2 10 266 M6	10	6.2	0.8	22.5	0.7	-	M 6	9.75	2
3 12 266 M6	12	6.2	0.8	22.5	0.7	-	M 6	11.5	3
4 16 266	16	6.2	0.8	27.5	0.7	-	M 8	13.8	4
5 20 266	20	6.2	0.8	27.5	0.7	-	M 10	18	5
5 25 266	25	6.2	0.8	32	0.7	-	M 12	21	5
7 32 266	32	6.2	0.8	32	0.7	-	M 16	29	7

End mills

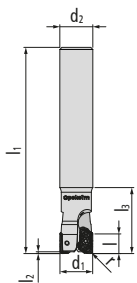

2 30 10 166 G	10	6.2	0.8	30	0.7	70	10	9.75	2
3 36 12 166 G	12	6.2	0.8	36	0.7	81	12	11.5	3
4 48 16 166 G	16	6.2	0.8	48	0.7	96	16	15.5	4

The accessories shown here must be used for all sizes!

Accessories

21 500 P	Torx screw	> Page 197
06 500 P	Torx wrench (Torx Plus)	> Page 198
SG25	TORQUE CliX-S grip	> Page 199
TG55	TORQUE CliX-T grip	> Page 199
DM06	Torque adapter 0.6 Nm	> Page 199
TP06-R	6-pack bits (Torx Plus)	> Page 200

Indexable inserts	Part no.	DIN designation	Quality	Coating	l	s	r	M
	02 66 835 R08	XCHT 062208 SR	HSC 05	PVTi	6.2	2.2	0.8	M 2
	02 66 835 R08 D	XCHT 062208 SR	HSC 05	PVDiaN	6.2	2.2	0.8	M 2

Application data (fz / ap)

Material							
Coating grade	Feed rate/ Depth of cut	Steel	Stainless steel	Cast iron	NF metal and non-metals	High-temperature resistant alloys	Hardened materials
HSC 05 PVTi	f _z (mm) a _p (mm)	0.05-0.3 0.3-2	0.05-0.25 0.3-2	0.05-0.3 0.3-2	-	0.05-0.25 0.3-2	0.05-0.25 0.3-2
HSC 05 PVDiaN	f _z (mm) a _p (mm)	-	-	-	0.05-0.3 0.3-2	-	-

Spindle speed (Vc in m/min)

Material							
Coating grade	Application	Steel	Stainless steel	Cast iron	NF metal and non-metals	High-temperature resistant alloys	Hardened materials
HSC 05 PVTi	Roughing	-	-	-	-	-	-
	Semi-Finish	-	-	-	-	-	-
	Finish	▽150 275 400	▽100 150 200	▽200 275 350	-	▽40 70 100	▽35 143 250
HSC 05 PVDiaN	Roughing	-	-	-	-	-	-
	Semi-Finish	-	-	-	-	-	-
	Finish	-	-	-	▽200 500 800	-	-

Expanded application data

Full axial plunge		Full oblique plunge			Circular milling		
Arbor Ø d1	X _{max} mm	Arbor Ø d1	α°	y mm	Arbor Ø d1	D _{min} mm	D _{max} mm
10-32	0.7	10	<2.5	4	10	13	20
		12	<2	6	12	17	24
		16	<1.6	10	16	25	32
		20	<1.2	14	20	33	39
		25	<1	19	25	43	49
		32	<1	26	32	57	63

SLOTWORX® K90°

SLOTWORX® - size M - Ø 16 - 52 mm



Characteristics:

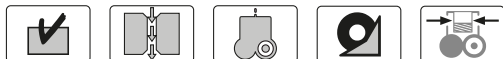

Milling cutter bodies	Part no.	d ₁	l	r	l ₃	l ₂	l ₁	d ₂	d ₃	z
-----------------------	----------	----------------	---	---	----------------	----------------	----------------	----------------	----------------	---

DuoPlug®

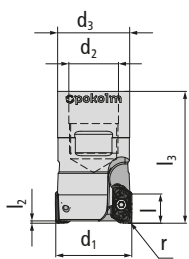

2 16 267 SG	16	10	0.8-2	38	2.5	-	M 10	15	2
2 20 267 SG	20	10	0.4-2	40	2.5	-	M 12	18.6	2
3 25 267 SG	25	10	0.4-2	43	2.5	-	M 16	23.5	3

Accessories

25 505 KP

Screw for Slotworx M Ø16;20;25

> Page 197

Threaded shank end mill body

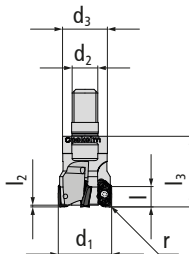

2 16 267	16	10	0.4-2	29	2.5	-	M 8	13.8	2
2 20 267	20	10	0.4-2	29	2.5	-	M 10	18	2
3 20 267	20	10	0.4-2	29	2.5	-	M 10	18	3
3 25 267	25	10	0.4-2	33	2.5	-	M 12	21	3
4 25 267	25	10	0.4-2	33	2.5	-	M 12	21	4

Accessories

25 505 KP

Screw for Slotworx M Ø16;20;25

> Page 197

4 32 267	32	10	0.4-2	43	2.5	-	M 16	29	4
5 32 267	32	10	0.4-2	43	2.5	-	M 16	29	5
5 42 267	42	10	0.4-2	43	2.5	-	M 16	29	5

Accessories

25 505 P

Screw for Slotworx M Ø 32;42;52

> Page 197

End mills

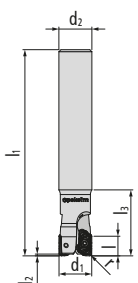

2 32 16 167 G	16	10	0.4-2	32	2.5	165	16	-	2
3 40 20 167 G	20	10	0.4-2	40	2.5	165	20	-	3
3 50 25 167 G	25	10	0.4-2	50	2.5	225	25	-	3
4 50 25 167 G	25	10	0.4-2	50	2.5	225	25	-	4

Accessories

25 505 KP

Screw for Slotworx M Ø16;20;25

> Page 197

Milling cutter bodies	Part no.	d_1	l	r	l_3	l_2	l_1	d_2	d_3	z
-----------------------	----------	-------	-----	-----	-------	-------	-------	-------	-------	-----

Shell-type milling cutter body

	5 42 367	42	10	0.4-2	43	2.5	–	16	35	5	
	6 52 367	52	10	0.4-2	53	2.5	–	22	40	6	
Accessories	25 505 P	Screw for Slotworx M Ø 32;42;52						> Page 197			

The accessories shown here must be used for all sizes!	Accessories	08 500 P	Torx wrench (Torx Plus)	> Page 198
		SG25	TORQUE CLIX-S grip	> Page 199
		TG55	TORQUE CLIX-T grip	> Page 199
		DM10	Torque adapter 1.0 Nm	> Page 199
		T10-R	6-pack bits (Torx [®])	> Page 200

<2/2

Indexable inserts	Part no.	DIN designation	Quality	Coating	l	s	r	M
-------------------	----------	-----------------	---------	---------	-----	-----	-----	-----

	04 67 820 R04	XDHT 10T304 FR	K10	Polished	10	3.58	0.4	M 2.5
	04 67 820 R08	XDHT 10T308 FR	K10	Polished	10	3.58	0.8	M 2.5
	04 67 837 R08	XDMT 10T308 ER	HSC 05	PVFN	10	3.58	0.8	M 2.5
	04 67 848 R08	XDMT 10T308 ER	P40	PVGO	10	3.58	0.8	M 2.5
	04 67 896 R08	XDMT 10T308 ER	M40	PVST	10	3.58	0.8	M 2.5
	04 67 8099 R08	XDMT 10T308 ER	M35	PCTC	10	3.58	0.8	M 2.5
	04 67 820	XDHT 10T310 ER	K10	Polished	10	3.58	1	M 2.5
	04 67 837	XDMT 10T310 ER	HSC 05	PVFN	10	3.58	1	M 2.5
	04 67 844	XDHT 10T310 ER	P40	PVGO	10	3.58	1	M 2.5
	04 67 848	XDMT 10T310 ER	P40	PVGO	10	3.58	1	M 2.5
	04 67 860	XDHT 10T310 ER	K10	PVTi	10	3.58	1	M 2.5
	04 67 860 D	XDHT 10T310 ER	K10	PVDiaN	10	3.58	1	M 2.5
	04 67 894	XDHT 10T310 ER	PKD	uncoated	10	3.58	1	M 2.5
	04 67 896	XDMT 10T310 ER	M40	PVST	10	3.58	1	M 2.5
	04 67 820 R20	XDHT 10T320 FR	K10	Polished	10	3.58	2	M 2.5
	04 67 896 R20	XDMT 10T320 ER	M40	PVST	10	3.58	2	M 2.5
	04 67 820 R30	XDHT 10T330 FR	K10	Polished	10	3.58	3	M 2.5
	04 67 896 R30	XDMT 10T330 ER	M40	PVST	10	3.58	3	M 2.5
	04 67 820 R40	XDHT 10T340 FR	K10	Polished	10	3.58	4	M 2.5
	04 67 896 R40	XDMT 10T340 ER	M40	PVST	10	3.58	4	M 2.5

Application data (fz / ap)

Material							
Coating grade	Feed rate/ Depth of cut	Steel	Stainless steel	Cast iron	NF metal and non-metals	High-temperature resistant alloys	Hardened materials
r=0.4 mm							
K10 Polished	f _z (mm) a _p (mm)	–	–	–	0.08-0.35 0.1-9	–	–
r=0.8 mm							
K10 Polished	f _z (mm) a _p (mm)	–	–	–	0.08-0.35 0.1-9	–	–
HSC 05 PVFN	f _z (mm) a _p (mm)	0.05-0.25 0.1-5	–	0.05-0.25 0.1-4	–	–	0.08-0.25 0.1-5
P40 PVGO	f _z (mm) a _p (mm)	0.05-0.25 0.1-6	0.05-0.25 0.1-3	0.05-0.25 0.1-6	–	0.05-0.25 0.1-3	–
M40 PVST	f _z (mm) a _p (mm)	0.05-0.25 0.1-6	0.08-0.35 0.1-9	–	–	0.08-0.25 0.1-9	–
M35 PCTC	f _z (mm) a _p (mm)	–	0.08-0.35 0.1-9	–	–	0.08-0.25 0.1-9	–
r=1 mm							
K10 Polished	f _z (mm) a _p (mm)	–	–	–	0.08-0.35 0.1-9	–	–
HSC 05 PVFN	f _z (mm) a _p (mm)	0.05-0.25 0.1-5	–	0.05-0.25 0.1-4	–	–	0.08-0.25 0.1-5
P40 PVGO	f _z (mm) a _p (mm)	0.05-0.25 0.1-6	0.05-0.25 0.1-3	0.05-0.25 0.1-6	–	0.05-0.25 0.1-3	–
K10 PVTi	f _z (mm) a _p (mm)	–	–	–	0.08-0.35 0.1-9	0.08-0.12 0.1-3	0.08-0.15 0.1-1
K10 PVDiaN	f _z (mm) a _p (mm)	–	–	–	0.08-0.35 0.1-9	–	–
PKD uncoated	f _z (mm) a _p (mm)	–	–	–	0.08-0.2 0.1-4	–	–
M40 PVST	f _z (mm) a _p (mm)	0.05-0.25 0.1-6	0.08-0.35 0.1-9	–	–	0.08-0.25 0.1-9	–
r=2 mm							
K10 Polished	f _z (mm) a _p (mm)	–	–	–	0.08-0.35 0.1-9	–	–
M40 PVST	f _z (mm) a _p (mm)	–	0.08-0.35 0.1-9	–	–	0.08-0.25 0.1-9	–
r=3 mm							
K10 Polished	f _z (mm) a _p (mm)	–	–	–	0.08-0.35 0.1-9	–	–
M40 PVST	f _z (mm) a _p (mm)	–	0.08-0.35 0.1-9	–	–	0.08-0.25 0.1-9	–
r=4 mm							
K10 Polished	f _z (mm) a _p (mm)	–	–	–	0.08-0.35 0.1-9	–	–
M40 PVST	f _z (mm) a _p (mm)	–	0.08-0.35 0.1-9	–	–	0.08-0.25 0.1-9	–

Spindle speed (Vc in m/min)

Material							
Coating grade	Application	Steel	Stainless steel	Cast iron	NF metal and non-metals	High-temperature resistant alloys	Hardened materials
K10 Polished	Roughing	–	–	–	▽100 450 800	–	–
	Semi-Finish	–	–	–	▽100 450 800	–	–
	Finish	–	–	–	▽100 450 800	▽40 70 100	–
HSC 05 PVFN	Roughing	▽120 160 200	–	▽100 150 200	–	–	▽80 150 220
	Semi-Finish	▽120 160 200	–	▽100 150 200	–	–	▽40 130 220
	Finish	–	–	–	–	–	▽40 130 220
P40 PVGO	Roughing	▽100 150 200	▽90 110 130	▽110 130 150	–	▽60 80 100	–
	Semi-Finish	▽100 150 200	▽90 110 130	▽110 130 150	–	▽60 80 100	–
	Finish	▽160 205 250	▽110 135 160	▽120 150 180	–	▽80 100 120	–
M40 PVST	Roughing	▽80 140 200	▽80 130 180	–	–	▽30 55 80	–
	Semi-Finish	▽100 150 200	▽100 155 210	–	–	▽40 65 90	–
	Finish	–	▽120 185 250	–	–	▽60 90 120	–
M35 PCTC	Roughing	–	▽110 155 200	–	–	▽30 65 100	–
	Semi-Finish	–	▽120 175 230	–	–	▽40 75 110	–
	Finish	–	▽160 220 280	–	–	▽60 100 140	–
K10 PVTi	Roughing	–	–	–	▽100 450 800	–	–
	Semi-Finish	–	–	–	▽100 450 800	–	–
	Finish	–	–	–	▽100 450 800	▽35 68 100	▽35 143 250
K10 PVDiaN	Roughing	–	–	–	▽100 450 800	–	–
	Semi-Finish	–	–	–	▽100 450 800	–	–
	Finish	–	–	–	▽100 450 800	–	–
PKD uncoated	Roughing	–	–	–	▽200 400 600	–	–
	Semi-Finish	–	–	–	▽400 600 800	–	–
	Finish	–	–	–	▽600 800 1000	–	–

Expanded application data

Full axial plunge		Full oblique plunge			Circular milling		
Arbor Ø d1	X _{max} mm	Arbor Ø d1	α°	y mm	Arbor Ø d1	D _{min} mm	D _{max} mm
16-52	2.5	16	<24.5	5.3	16	21.3	32
		20	<14.5	9.3	20	29.3	40
		25	<8	14.3	25	39.3	50
		32	<5	21.3	32	53.3	64
		42	<3	31.3	42	73.3	84
		52	<2.5	41.3	52	93.3	104

SLOTWORX® K90°

SLOTWORX® - size L - Ø 25 - 100 mm



Characteristics:

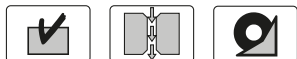

Milling cutter bodies	Part no.	d_1	l	r	l_3	l_2	l_1	d_2	d_3	z	
Threaded shank end mill body											
	2 25 268	25	15	1-3	35	3	–	M 12	21	2	
	3 32 268	32	15	1-3	43	3	–	M 16	29	3	
	4 40 268	40	15	1-3	43	3	–	M 16	29	4	
	4 42 268	42	15	1-3	43	3	–	M 16	29	4	
Shell-type milling cutter body											
	4 40 368	40	15	1-3	43	3	–	16	35	4	
	4 42 368	42	15	1-3	43	3	–	16	35	4	
	5 50 368	50	15	1-3	53	3	–	22	40	5	
	5 52 368	52	15	1-3	53	3	–	22	40	5	
	6 63 368	63	15	1-3	53	3	–	27	48	6	
	6 66 368	66	15	1-3	53	3	–	27	48	6	
	7 80 368	80	15	1-3	53	3	–	27	60	7	
	9 100 368	100	15	1-3	53	3	–	32	70	9	
<p>The accessories shown here must be used for all sizes!</p>	Accessories	35 500	Torx screw						> Page 197		
		15 500	Torx wrench						> Page 197		
		SG25	TORQUE CliX-S grip						> Page 199		
		TG55	TORQUE CliX-T grip						> Page 199		
		DM25	Torque adapter 2.5 Nm						> Page 199		
		T15-R	6-pack bits (Torx)						> Page 200		

Indexable inserts	Part no.	DIN designation	Quality	Coating	l	s	r	M
	05 68 820	XDHT 155210 FR	K10	Polished	15	5.2	1	M 3.5
	05 68 848	XDMT 155210 ER	P40	PVGO	15	5.2	1	M 3.5
	05 68 862	XDMT 155210 ER	K10	PVTi	15	5.2	1	M 3.5
	05 68 896	XDMT 155210 ER	M40	PVST	15	5.2	1	M 3.5
	05 68 820 R20	XDHT 155230 FR	K10	Polished	15	5.2	2	M 3.5
	05 68 896 R20	XDMT 155220 ER	M40	PVST	15	5.2	2	M 3.5
	05 68 820 R30	XDHT 155230 FR	K10	Polished	15	5.2	3	M 3.5
	05 68 896 R30	XDMT 155230 ER	M40	PVST	15	5.2	3	M 3.5
	05 68 820 R40	XDHT 155240 FR	K10	Polished	15	5.2	4	M 3.5
	05 68 896 R40	XDMT 155240 ER	M40	PVST	15	5.2	4	M 3.5
	05 68 820 R50	XDHT 155250 FR	K10	Polished	15	5.2	5	M 3.5
	05 68 896 R50	XDMT 155250 ER	M40	PVST	15	5.2	5	M 3.5

Application data (fz / ap)

Material							
Coating grade	Feed rate/ Depth of cut	Steel	Stainless steel	Cast iron	NF metal and non-metals	High-temperature resistant alloys	Hardened materials
K10 Polished	f _z (mm) a _p (mm)	–	–	–	0.08-0.35 0.1-14	–	–
P40 PVGO	f _z (mm) a _p (mm)	0.1-0.5 0.2-14	–	0.1-0.5 0.2-14	–	–	–
K10 PVTi	fz (mm) ap (mm)	0.1-0.4 4-14	–	0.1-0.4 0.2-14	–	–	–
M40 PVST	f _z (mm) a _p (mm)	–	0.08-0.5 0.1-14	–	–	0.08-0.25 0.1-14	–

Spindle speed (Vc in m/min)

Material							
Coating grade	Application	Steel	Stainless steel	Cast iron	NF metal and non-metals	High-temperature resistant alloys	Hardened materials
K10 Polished	Roughing Semi-Finish Finish	–	–	–	▼100 450 800 ▼100 450 800 ▼100 450 800	–	–
P40 PVGO	Roughing Semi-Finish Finish	▼100 150 200 ▼100 150 200 ▼160 205 250	–	▼110 130 150 ▼110 130 150 ▼120 150 180	–	–	–
K10 PVTi	Roughing Semi-Finish Finish	▼130 170 210 ▼150 185 220 –	–	▼150 175 200 ▼150 175 200 ▼150 200 250	–	–	–
M40 PVST	Roughing Semi-Finish Finish	–	▼80 130 180 ▼100 155 210 ▼120 185 250	–	–	▼30 55 80 ▼40 65 90 ▼60 90 120	–

Expanded application data

Full axial plunge

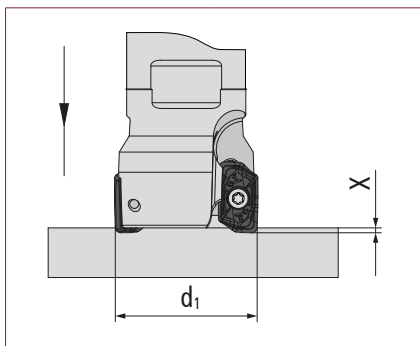

Arbor
Ø d1

X_{max}
mm

25-100

3

Full oblique plunge

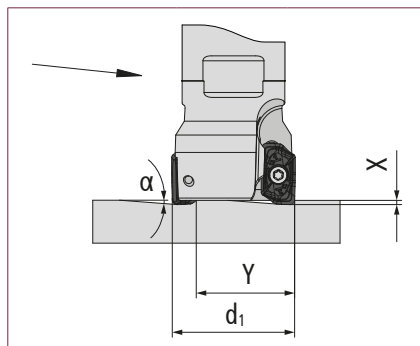

Arbor
Ø d1

α°

y
mm

25

<8.3

17

32

<5.9

24

40

<4.4

32

42

<4.2

34

50

<3.3

42

52

<3.2

44

63

<2.5

55

66

<2.4

58

80

<1.9

72

100

<1.5

92

Circular milling

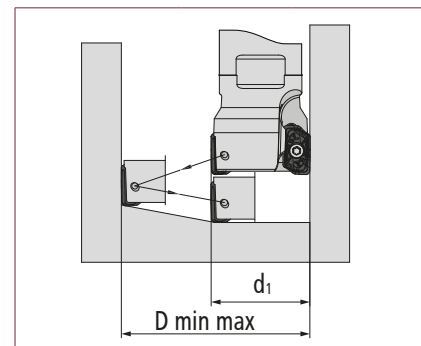

Arbor
Ø d1

D_{min}
mm

D_{max}
mm

25

42

50

32

56

64

40

72

80

42

76

84

50

92

100

52

96

104

63

118

126

66

124

132

80

152

160

100

192

200



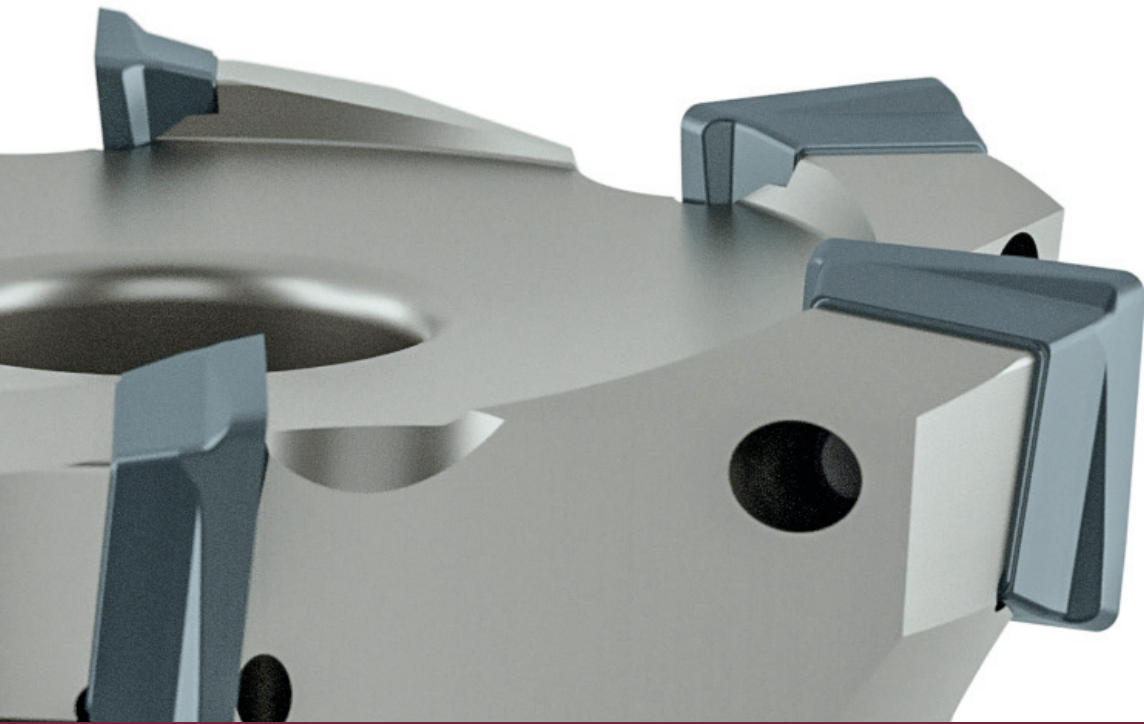

QUADWORX®XL sharp corner and slot milling cutters

made in germany
OKOIM

QUADWORX®XL sharp corner and slot milling cutters

squaring the insert - excellent affordability for universal use



Properties

- universal use as a sharp corner and slot milling cutter
- very high material removal rates and extremely easy cutting for more machine capacity
- 4 cutting flutes / cutting insert for highly economical use
- torsion eliminated by positioning the cutting inserts over a second flank and 90° contact
- maximum process reliability in interrupted cuts thanks to secure positioning of the inserts
- cutter bodies with the designation RF are equally divided and have a hook of 5°

Sizes	Page
XL: Ø 32 - 100 mm	48

Machining types

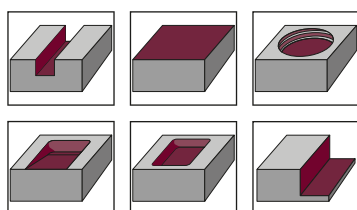

Connection types

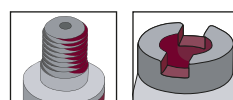

Cutting materials

Size	ISO application						Application data (mm)		Length (mm)	Bull end (mm)	Quality / coating
	P	M	K	N	S	H	f_z	a_p	l	r	
XL				-		-	0.05 - 0.5	0.05 - 8	13	1	P40 PVGO P25 PVGO M40 PVST

QUADWORX® XL - K90°

Size XL - Ø 32 - 100 mm



Milling cutter bodies	Part no.	d ₁	l	r	l ₃	l ₂	l ₁	d ₂	d ₃	z
-----------------------	----------	----------------	---	---	----------------	----------------	----------------	----------------	----------------	---

Threaded shank end mill body

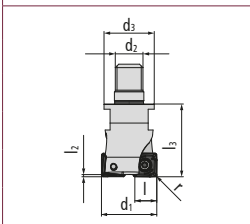

2 32 251	32	13	1	42	1.5	–	M 16	29	2
3 35 251	35	13	1	42	1.5	–	M 16	29	3

Shell-type milling cutter body

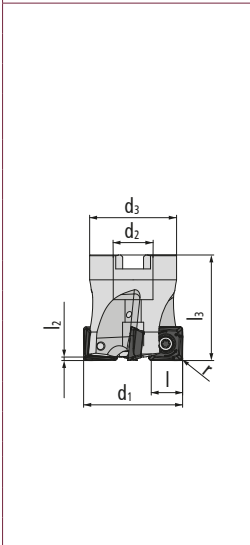

4 40 351	40	13	1	42.5	2.5	–	16	35	4	
4 42 351	42	13	1	42.5	2.5	–	16	35	4	
Accessories	GWSTPS8ISK		Setscrew with hexagon socket				> Page 198			
4 50 351	50	13	1	50	2.5	–	22	40	4	
5 50 351	50	13	1	50	2.5	–	22	40	5	
5 50 351 RF	50	13	1	50	2.5	–	22	40	5	
5 52 351	52	13	1	50	2.5	–	22	48	5	
5 52 351 RF	52	13	1	50	2.5	–	22	48	5	
6 63 351	63	13	1	53	2.5	–	27	48	6	
6 63 351 RF	63	13	1	53	2.5	–	27	48	6	
6 66 351	66	13	1	53	2.5	–	27	48	6	
6 66 351 RF	66	13	1	53	2.5	–	27	48	6	
6 80 351	80	13	1	53	2.5	–	27	60	6	
8 80 351	80	13	1	53	2.5	–	27	60	8	
7 100 351	100	13	1	53	2.5	–	32	70	7	
9 100 351	100	13	1	53	2.5	–	32	70	9	
Accessories	40 505 K		Torx screw				> Page 197			

The accessories shown here must be used for all sizes!

Accessories

15 500 P	Torx wrench (Torx Plus)	> Page 197
40 505 K	Torx screw	> Page 197
SG25	TORQUE CliX-S grip	> Page 199
TG55	TORQUE CliX-T grip	> Page 199
DM38	Torque adapter 3.8 Nm	> Page 199
TP15-R	6-pack bits (Torx Plus)	> Page 200

Indexable inserts	Part no.	DIN designation	Quality	Coating	l	s	r	M
-------------------	----------	-----------------	---------	---------	---	---	---	---

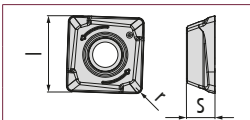

05 51 848	SDMT 135010 SN	P40	PVGO	13	5	1	M 4
05 51 858	SDMT 135010 SN	P25	PVGO	13	5	1	M 4
05 51 896	SDMT 135010 EN	M40	PVST	13	5	1	M 4

Application data (fz / ap)

Material							
Coating grade	Feed rate/ Depth of cut	Steel	Stainless steel	Cast iron	NF metal and non-metals	High-temperature resistant alloys	Hardened materials
P40 PVGO	f _z (mm) a _p (mm)	0.1-0.5 0.2-8	-	0.1-0.5 0.2-8	-	-	-
P25 PVGO	f _z (mm) a _p (mm)	0.1-0.5 0.2-8	-	0.1-0.5 0.2-8	-	-	-
M40 PVST	f _z (mm) a _p (mm)	-	0.05-0.3 0.1-6	-	-	0.05-0.25 0.05-6	-

Speed (Vc in m/min)

Material							
Coating grade	Application	Steel	Stainless steel	Cast iron	NF metal and non-metals	High-temperature resistant alloys	Hardened materials
P40 PVGO	Roughing	▽100 150 200	-	▽110 130 150	-	-	-
	Semi-Finish	▽100 150 200	-	▽110 130 150	-	-	-
	Finish	▽160 205 250	-	▽120 150 180	-	-	-
P25 PVGO	Roughing	▽110 165 220	-	▽120 145 170	-	-	-
	Semi-Finish	▽120 185 250	-	▽130 150 170	-	-	-
	Finish	▽150 225 300	-	▽135 193 250	-	-	-
M40 PVST	Roughing	-	▽80 130 180	-	-	▽30 55 80	-
	Semi-Finish	-	▽100 155 210	-	-	▽40 65 90	-
	Finish	-	▽120 185 250	-	-	▽60 90 120	-

Expanded application data

Full axial plunge		Full oblique plunge			Circular milling		
Arbor Ø d1	X _{max} mm	Arbor Ø d1	α°	y mm	Arbor Ø d1	D _{min} mm	D _{max} mm
32-35	1.5	32	<9	8.8	32	40.8	62
40-100	2.5	35	<7.0	11.8	35	46.8	68
		40	<6.5	16.8	40	56.8	78
		42	<5.8	18.8	42	60.8	82
		50	<4.1	26.8	50	76.8	98
		52	<3.7	28.8	52	80.8	102
		63	<2.6	39.8	63	102.8	124
		66	<2.4	42.8	66	108.8	130
		80	<1.8	56.8	80	136.8	158
		100	<1.2	72.8	100	176.8	198

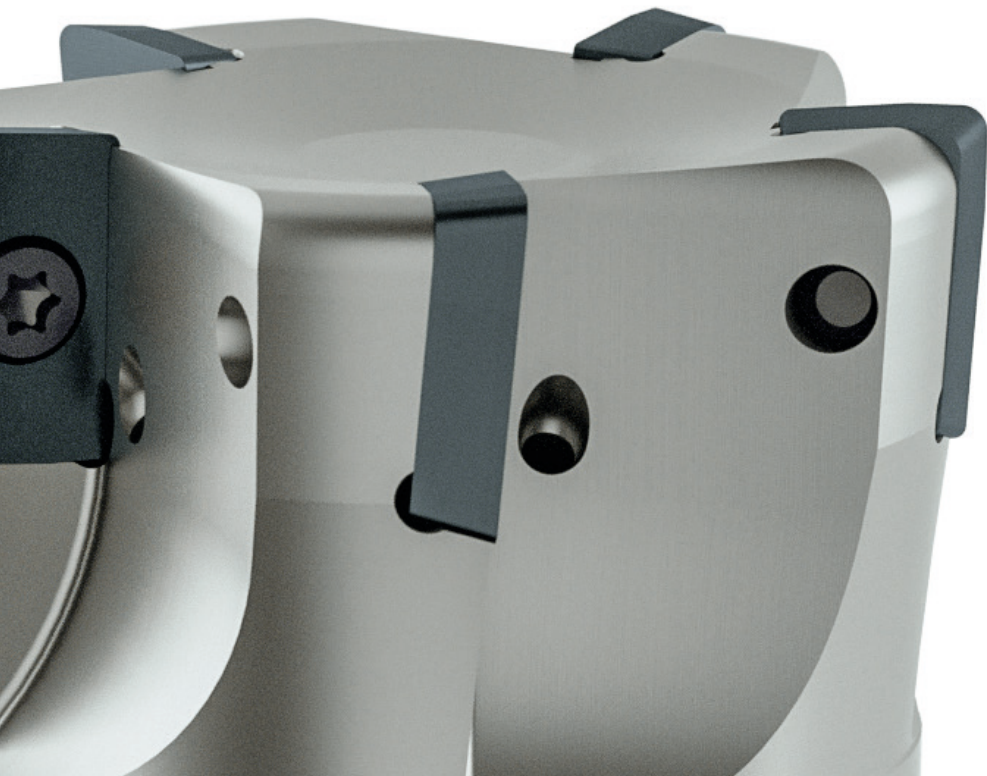

SLOTWORX® VF sharp
corner and slot milling cutters



SLOTWORX® VF Finishing cutter

Ø 16 - 42 mm | Size M

Properties

- finishing wall or floor surfaces
- large number of teeth for excellent feed rate
- available as threaded or DuoPlug® interface
- R 0.8 on the indexable insert reduces cutting pressure
- in addition, an indexable insert with R2 was developed
- newly designed cutter body with addition of R+ is suitable for use of both indexable inserts R0.8 and R2



Sizes	Page
Ø 16 - 42 mm	52

Machining types

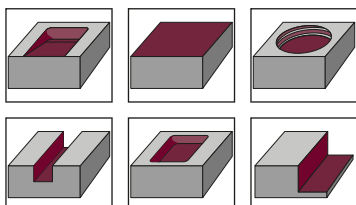

Connection types

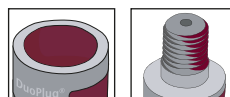

Cutting materials

Coating grade	ISO application						Application data (mm)		Cutting flute length	Thickness	Radius
	P	M	K	N	S	H	f _z	a _p	l (mm)	s (mm)	r (mm)
HSC 05 PPTi	▼	▼	▼	▼	▼	▼	0.05 - 0.3	0.5 - 2.8	9.52	2.38	0.8
HSC 05 PPTi	▼	▼	▼	▼	▼	▼	0.05 - 0.3	0.5 - 2.8	9.52	2.38	2.0

SLOTWORX® VF

Ø 16 - 42 mm | Size M

New

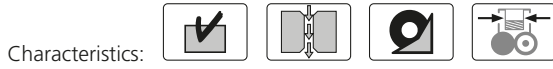

Milling cutter bodies	Part no.	d ₁	l	r	l ₃	l ₂	l ₁	d ₂	d ₃	z
-----------------------	----------	----------------	---	---	----------------	----------------	----------------	----------------	----------------	---

DuoPlug®

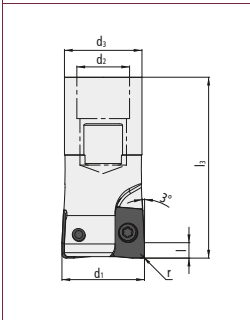

VF09-016-D10-02-R+	16	3	0.8	35	–	–	M 10	15	2
VF09-020-D12-03-R+	20	3	0.8	37.5	–	–	M 12	18.6	3
VF09-025-D16-04-R+	25	3	0.8	42	–	–	M 16	23.5	4

Threaded shank end mill body

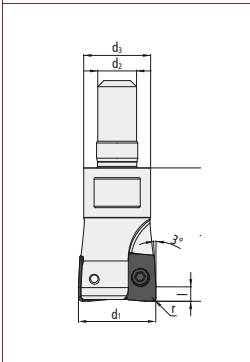

VF09-016-E08-02-R+	16	3	0.8	27.5	–	–	M 8	13.8	2
VF09-020-E10-03-R+	20	3	0.8	27.5	–	–	M 10	18	3
VF09-025-E12-04-R+	25	3	0.8	32.5	–	–	M 12	21	4
VF09-032-E16-05-R+	32	3	0.8	32.5	–	–	M 16	29	5
VF09-035-E16-06-R+	35	3	0.8	32.5	–	–	M 16	29	6
VF09-042-E16-07-R+	42	3	0.8	32.5	–	–	M 16	29	7

The accessories shown here must be used for all sizes!

Accessories

25 500	Torx screw	> Page 197
07 500	Torx wrench	> Page 198
SG25	TORQUE CLIX-S grip	> Page 199
TG55	TORQUE CLIX-T grip	> Page 199
DM09	Torque adapter 0.9 Nm	> Page 199
T07-R	6-pack bits (Torx)	> Page 200

Indexable inserts	Part no.	DIN designation	Quality	Coating	l	s	r	M
-------------------	----------	-----------------	---------	---------	---	---	---	---

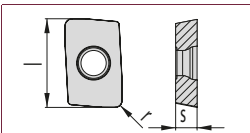

VF09-8035-R08-LH-2	BPHX 090308 PER-1,5	HSC 05	PPTi	9.52	2.38	0.8	M 2.5
VF09-8035-R20-LH-2	BPHX 090320 PER	HSC 05	PPTi	9.52	2.38	2.0	M 2.5

Application data (fz / ap)

Material							
Coating grade	Feed rate/ Depth of cut	Steel	Stainless steel	Cast iron	NF metal and non-metals	High-temperature resistant alloys	Hardened materials
HSC 05 PPTi	f _z (mm) a _p (mm)	0.05-0.2 0.5-2.8	0.05-0.12 0.5-2	0.05-0.15 0.5-2.5	0.05-0.3 0.3-2	0.05-0.12 0.5-2	0.05-0.17 0.5-2.5

Spindle speed (Vc in m/min)

Material							
Coating grade	Application	Steel	Stainless steel	Cast iron	NF metal and non-metals	High-temperature resistant alloys	Hardened materials
HSC 05 PPTi	Roughing Semi-Finish Finish	– – ▼135 225 450	– – ▼110 165 220	– – ▼160 225 290	– – ▼200 500 800	– – ▼60 110 160	– – ▼120 180 250

Note: The indexable insert "VF09-8035-R20-LH-2" with radius R2 can only be used in cutter bodies with the addendum of R+!
Indexable inserts with a radius R0.8 can also be used in cutter bodies with the addendum R+.

SQUAREWORX® SHARP CORNER, SLOT AND CHAMFER MILLING WITH JUST ONE CUTTING INSERT

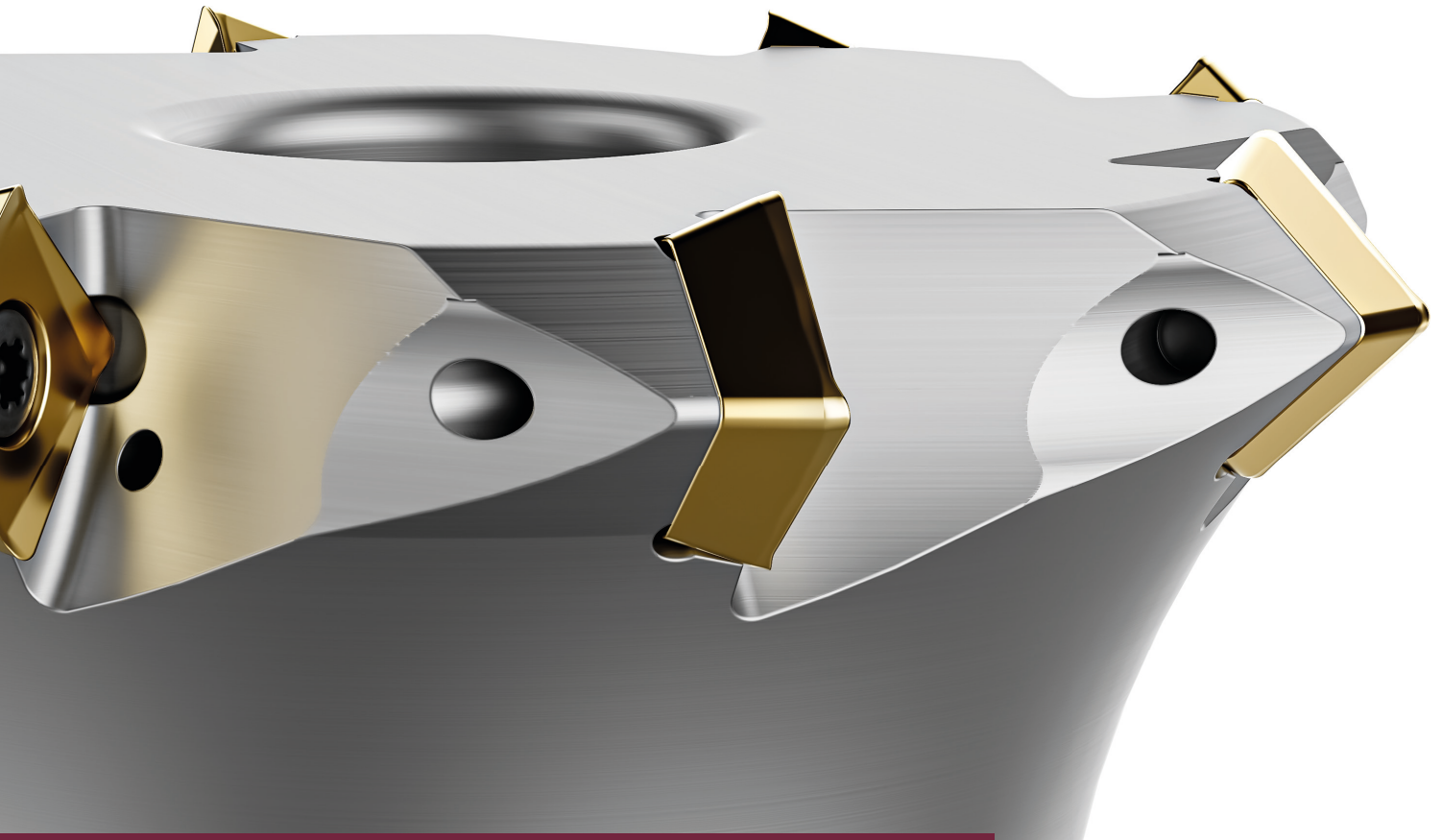

SQUAREWORX®

Sharp corner, slot
and chamfer mills

pokolm
made in Germany

SQUAREWORX®

One for two

Sharp corner, slot and chamfer milling with just one cutting insert and two carriers



Properties

- Tool K=90°: precise sharp corner, slot and slab milling, embedded cutting inserts
- Tool K=45°: forwards and backwards chamfering, as well as deburring to $a_p=5$ mm
- Low storage costs thanks to just one cutting insert for both tool geometries
- 4 usable cutting flutes per insert, low costs for each cutting flute
- 15° relief, bull end =0.8 mm
- Large no. of teeth ensures high feed rates
- For roughing, cutting and finishing
- Inserts for almost any material: peripheral grinding, very sharp inserts for non-ferrous materials; sintered inserts for all other materials

Sizes	Page
Diameter 25 - 66 K= 90°	57
Diameter 16 - 63 K= 45°	58

Machining types

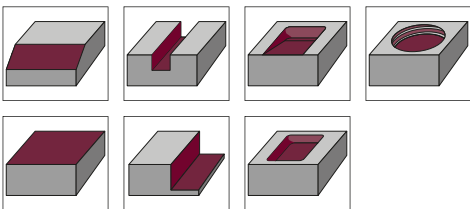

Connection types

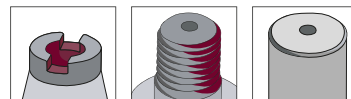

Cutting materials

Practical video SQUAREWORX®

More product videos are available at:
youtube.de/pokolmknowhow



Coating grade	ISO application						Application data (mm)		Cutting flute length	Thickness	Radius
	P	M	K	N	S	H	f_z	a_p	l (mm)	s (mm)	r (mm)
P40 PPGO	▲	▲	▲	-	▲	-	0.05 - 0.3	0.1 - 5	9	3.97	0.8
K10 PCSR	▲	-	▲	-	-	-	0.05 - 0.2	0.1 - 5	9	3.97	0.8
M35 PCTC	-	▲	-	-	▲	-	0.05 - 0.25	0.1 - 5	9	3.97	0.8
M40 PPST	▲	▲	-	-	▲	-	0.04 - 0.25	0.1 - 5	9	3.97	0.8
K10 Polished	-	-	-	▲	-	-	0.05 - 0.35	0.1 - 5	9	3.97	0.8

SQUAREWORX® in detail

One cutting insert for two carriers

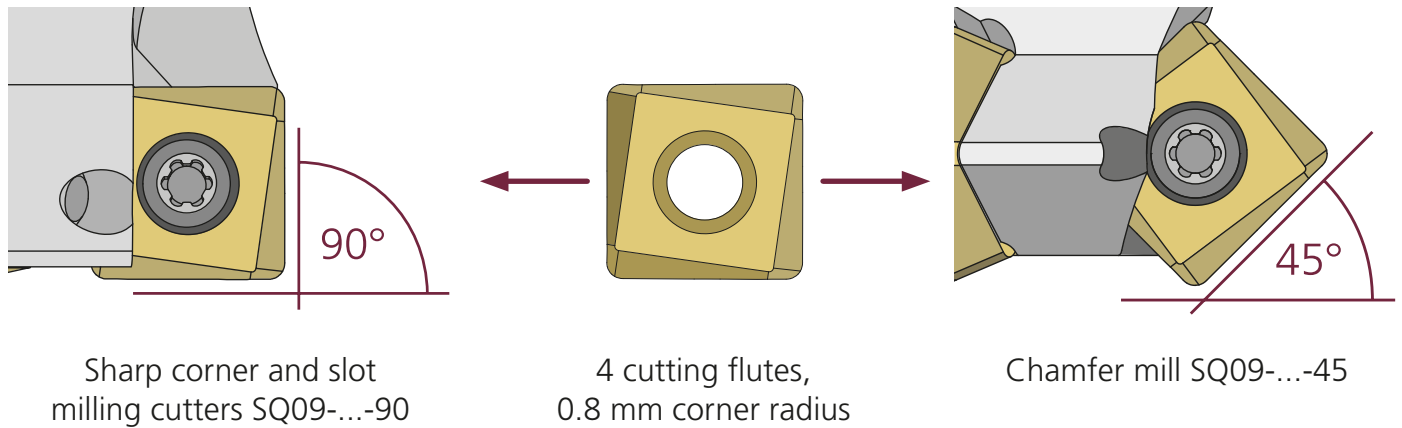

SQUAREWORX - order number key

Tool cutter body:

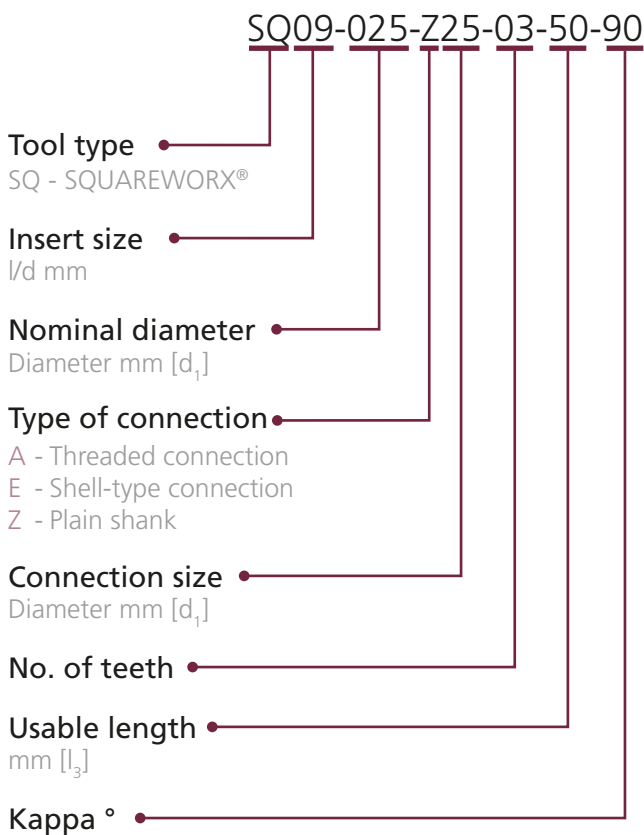

Inserts

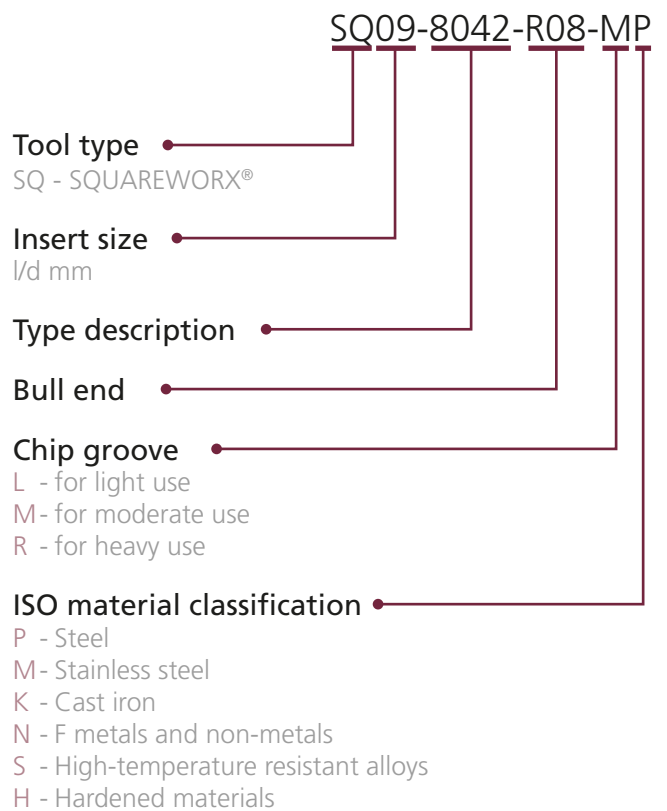

SQUAREWORX®

Size M | Sharp corner and slot milling cutters - K=90°



Characteristics:

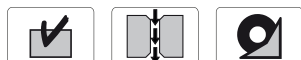

Milling Cutter Bodies	Part no.	d_1	l	r	l_3	l_2	l_1	d_2	d_3	z
-----------------------	----------	-------	-----	-----	-------	-------	-------	-------	-------	-----

End mills

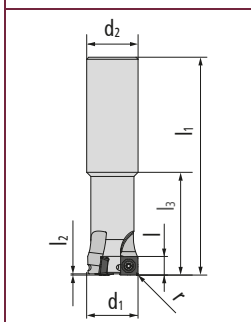

SQ09-025-Z25-03-50-90	25	9	0.8	50	1	-	25	24	3
-----------------------	----	---	-----	----	---	---	----	----	---

Threaded shank end mill body

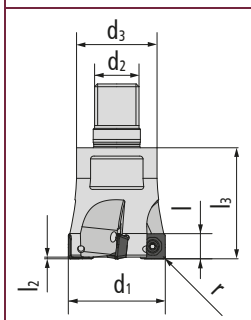

SQ09-025-E12-03-90	25	9	0.8	35	1	-	M 12	21	3
SQ09-032-E16-04-90	32	9	0.8	40	1	-	M 16	29	4
SQ09-035-E16-04-90	35	9	0.8	40	1	-	M 16	29	4
SQ09-040-E16-05-90	40	9	0.8	40	1	-	M 16	29	5
SQ09-042-E16-05-90	42	9	0.8	40	1	-	M 16	29	5

Shell-type milling cutter body

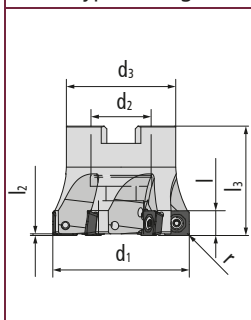

SQ09-040-A16-05-90	40	9	0.8	40	1	-	16	35	5
SQ09-042-A16-05-90	42	9	0.8	40	1	-	16	35	5
SQ09-050-A22-06-90	50	9	0.8	40	1	-	22	40	6
SQ09-052-A22-06-90	52	9	0.8	40	1	-	22	40	6
SQ09-063-A27-07-90	63	9	0.8	50	1	-	27	48	7
SQ09-066-A27-07-90	66	9	0.8	50	1	-	27	48	7

The accessories shown here must be used for all sizes!

Accessories

30 505 P	Torx screw	> Page 197
08 500 P	Torx wrench (Torx Plus)	> Page 198
SG25	TORQUE CLIX S-grip	> Page 199
TG55	TORQUE CLIX T-grip	> Page 199
DM15	Torque adapter 1.5 Nm	> Page 199
TP08-R	6-pack bits (Torx Plus)	> Page 200

SQUAREWORX®

Size M | Chamfer mill - K=45°



Milling Cutter Bodies	Part no.	d_1	l	r	l_3	l_2	l_1	d_2	d_3	z
-----------------------	----------	-------	-----	-----	-------	-------	-------	-------	-------	-----

End mills

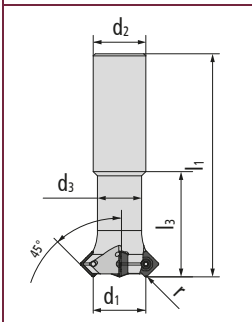

SQ09-016-Z16-03-32-45	16	9	0.8	32	1.2	-	16	13.8	3
SQ09-020-Z20-03-40-45	20	9	0.8	40	1.2	-	20	18	3
SQ09-025-Z25-04-50-45	25	9	0.8	50	1.2	-	25	21	4

Threaded shank end mill body

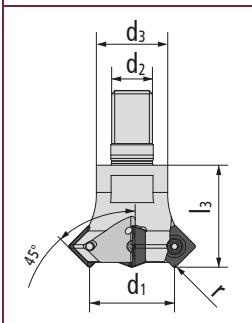

SQ09-016-E10-03-45	16	9	0.8	25	1.2	-	M 10	18	3
SQ09-020-E12-03-45	20	9	0.8	30	1.2	-	M 12	21	3
SQ09-025-E12-04-45	25	9	0.8	30	1.2	-	M 12	21	4
SQ09-035-E16-05-45	35	9	0.8	40	1.2	-	M 16	29	5

Shell-type milling cutter body

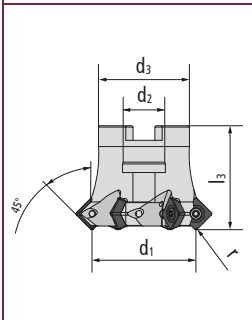

SQ09-040-A16-06-45	40	9	0.8	40	1.2	-	16	35	6
SQ09-050-A22-07-45	50	9	0.8	40	1.2	-	22	40	7
SQ09-063-A27-08-45	63	9	0.8	50	1.2	-	27	48	8

The accessories shown here must be used for all sizes!	Accessories	30 505 P	Torx screw	> Page 197
		08 500 P	Torx wrench (Torx Plus)	> Page 198
		SG25	TORQUE CLIX S-grip	> Page 199
		TG55	TORQUE CLIX T-grip	> Page 199
		DM15	Torque adapter 1.5 Nm	> Page 199
		TP08-R	6-pack bits (Torx Plus)	> Page 200

SQUAREWORX® PORCUPINE CUTTER

Size M | K=90°

Characteristics:

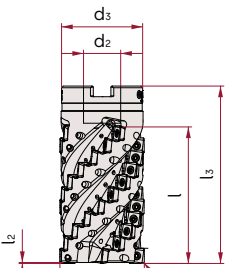

Milling Cutter Bodies	Part no.	d ₁	l	r	l ₃	l ₂	d ₂	d ₃	z	ges. z
-----------------------	----------	----------------	---	---	----------------	----------------	----------------	----------------	---	--------

Porcupine cutter										
	231607	40	44.2	0.8	70	1	16	38	3	18
	231608	40	65.6	0.8	90	1	16	38	3	27
	231609	50	51.2	0.8	75	1	22	48	4	28
	231610	50	80.8	0.8	105	1	22	48	4	44
	231611	66	72.8	0.8	92	1	27	60	5	50
	231612	66	101.4	0.8	120	1	27	60	5	70

<p>The accessories shown here must be used for all sizes!</p>	<p>Accessories</p>	30 505 P	Torx screw	> Page 197
		08 500 P	Torx wrench (Torx Plus)	> Page 198
		SG25	TORQUE CLIX S-grip	> Page 199
		TG55	TORQUE CLIX T-grip	> Page 199
		DM15	Torque adapter 1.5 Nm	> Page 199
		TP08-R	6-pack bits (Torx Plus)	> Page 200

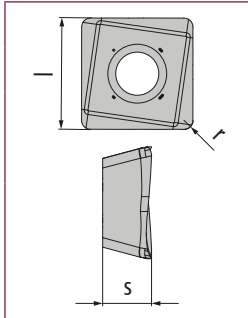
Indexable Inserts	Part no.	DIN designation	Quality	Coating	l	s	r	M
								
	SQ09-8048-R08-MP	SDKT 09T308 SR	P40	PPGO	9	3.97	0.8	M 3
	SQ09-8062-R08-MK	SDKT 09T308 SR	K10	PCSR	9	3.97	0.8	M 3
	SQ09-8099-R08-MS	SDKT 09T308 SR	M35	PCTC	9	3.97	0.8	M 3
	SQ09-8096-R08-MM	SDKT 09T308 SR	M40	PPST	9	3.97	0.8	M 3
	SQ09-8020-R08-MN	SDHT 09T308 FR	K10	Polished	9	3.97	0.8	M 3

Application data (fz / ap)

Material							
Coating grade	Feed rate/ Depth of cut	Steel	Stainless steel	Cast iron	NF metal and non-metals	High- temperature resistant alloys	Hardened materials
P40 PPGO	f _z (mm)	0.05 - 0.3	0.05- 0.17	0.05 - 0.2	–	0.04 - 0.13	–
	a _p (mm)	0.1 - 5	0.1 - 5	0.1 - 5	–	0.1 - 4	–
K10 PCSR	f _z (mm)	0.05 - 0.2	–	0.05 - 0.2	–	–	–
	a _p (mm)	0.1 - 2.5	–	0.1 - 5	–	–	–
M35 PCTC	f _z (mm)	–	0.05 - 0.25	–	–	0.05 - 0.25	–
	a _p (mm)	–	0.1 - 5	–	–	0.1 - 5	–
M40 PPST	f _z (mm)	0.05 - 0.25	0.04 - 0.25	–	–	0.04 - 0.15	–
	a _p (mm)	0.1 - 5	0.1 - 5	–	–	0.1 - 5	–
K10 Polished	f _z (mm)	–	–	–	0.05 - 0.35	–	–
	a _p (mm)	–	–	–	0.1 - 5	–	–

Spindle speed (Vc in m/min)

Material							
Coating grade	Application	Steel	Stainless steel	Cast iron	NF metal and non-metals	High- temperature resistant alloys	Hardened materials
P40 PPGO	Roughing	▽ 100 150 200	▽ 90 110 130	▽ 110 130 150		▽ 60 80 100	
	Semi-Finish	▽ 100 150 200	▽ 90 110 130	▽ 110 130 150		▽ 60 80 100	
	Finish	–	–	–		–	–
K10 PCSR	Roughing	–	–	▽ 140 180 220	–	–	–
	Semi-Finish	▽ 100 180 260	–	▽ 160 190 220	–	–	–
	Finish	–	–	▽ 160 190 220	–	–	–
M35 PCTC	Roughing	–	▽ 110 155 200	–	–	▽ 30 65 100	–
	Semi-Finish	–	▽ 120 175 230	–	–	▽ 40 75 110	–
	Finish	–	▽ 160 220 280	–	–	▽ 60 100 140	–
M40 PPST	Roughing	▽ 80 140 200	▽ 80 130 180	–	–	▽ 30 55 80	–
	Semi-Finish	▽ 100 150 200	▽ 1100 155 210	–	–	▽ 40 65 90	–
	Finish	–	▽ 120 185 250	–	–	▽ 60 90 120	–
K10 Polished	Roughing	–	–	–	▽ 100 450 800	–	–
	Semi-Finish	–	–	–	▽ 100 450 800	–	–
	Finish	–	–	–	▽ 100 450 800	–	–

Expanded application data

Full axial plunge		Full oblique plunge			Circular milling		
Arbor Ø d1	X _{max} mm	Arbor Ø d1	α°	y mm	Arbor Ø d1	D _{min} mm	D _{max} mm
25 - 32	0.5	25	<2.00	12.2	25	37.2	48
35	0.4	32	<1.50	19.2	32	51.2	62
40 - 63	0.3	35	<1.00	22.2	35	57.2	68
		40	<0.60	27.2	40	67.2	78
		42	<0.55	29.2	42	71.2	82
		50	<0.45	37.2	50	87.2	98
		52	<0.40	39.2	52	91.2	102
		63	<0.30	50.2	63	113.2	124
		66	<0.30	53.2	66	119.2	130

THINKING IN SOLUTIONS

100 22 710.01
467108
HSC

Spokolm
Made in Germany

Copy end mills



SPINWORX® innovative copy end mill system

For lightly manned production with self-turning cutting inserts



Properties

- 100% use of the complete cutting flute
- minimized set-up times, no manual re-locating of the inserts is necessary
- much longer tool life and chip volume without stopping the production process
- optimally suited for roughing and remaining material machining
- reduced chip compression leads to lower power consumption, which also protects your machine spindle

Sizes	Page
r 3.5 Ø 16 - 35 mm	65
r 5 Ø 20 - 52 mm	68
r 6 Ø 24 - 100 mm	72
r 8 Ø 32 - 125 mm	76
r 10 Ø 100 - 160 mm	80

Machining types

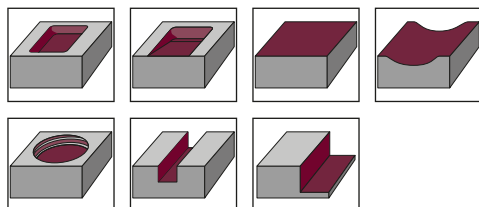

Connection types

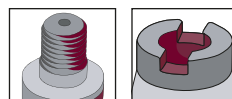

Practical video
SPINWORX® in 1.2738 /
tool life 13 hours /
40CrMnNiMo8-6-4



Cutting materials

Size	ISO application						d (mm)	Geometry / quality					
	P	M	K	N	S	H		0	1	3	4	6	7
r3.5	▼	▼	▼	▼	▼	▼	7	-	-	B	C, E, F	-	B
r5	▼	▼	▼	▼	▼	▼	10	-	-	B	C, E, F	-	B
r6	▼	▼	▼	▼	▼	▼	12	-	-	B	C, E, F	-	B
r8	▼	▼	▼	▼	▼	▼	16	-	-	B	C, E, F	-	B
r10	▼	▼	▼	▼	▼	▼	20	-	-	-	C, E, F	-	B

SPINWORX® copy end mill

Optimized cutter body tool contour

The geometry of SPINWORX® tools facilitates optimal chip removal, in particular when machining pockets and grooves. In addition, the rounded outer contour effectively prevents chips sticking to the tool.

The cutter body base material is the decisive factor

Spinworx cutter body tools are made of a high-quality base material in order to ensure extremely long tool run times with one set of cutting inserts.

Insert seat

The large transition radius of the seats in SPINWORX® tools prevents an increased notching effect from the start. Another advantage is that the base of the tooth cannot break off due to overload.

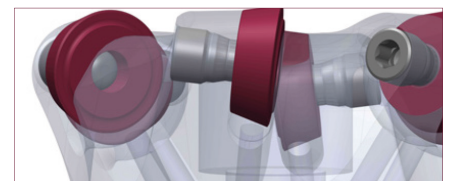
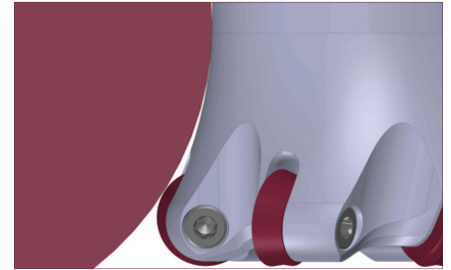

The self-rotating insert

One key component of the SPINWORX® tool system are self-rotating inserts, which are optimally matched to the cutter bodies. Here as well, the special design features ensure the reliable long-term function of these components. Cutting materials with and without chip groove and different cutting flute geometries are available to handle a wide range of applications.

Pin/insert combination

The cylindrical contact surface of the insert has an exactly defined percentage of contact area. The cylindrical part of the pin secures the additional support in the cutter body tool.

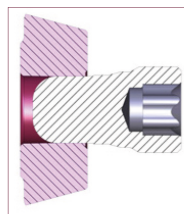

The race

All SPINWORX® inserts are equipped with a race. This ensures constant rotation, and supports the characteristics of the embedded insert seat.

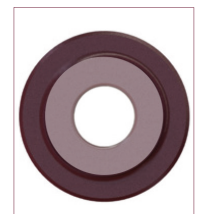

Order number key

Tool cutter body: **DR10-025-E12-03**

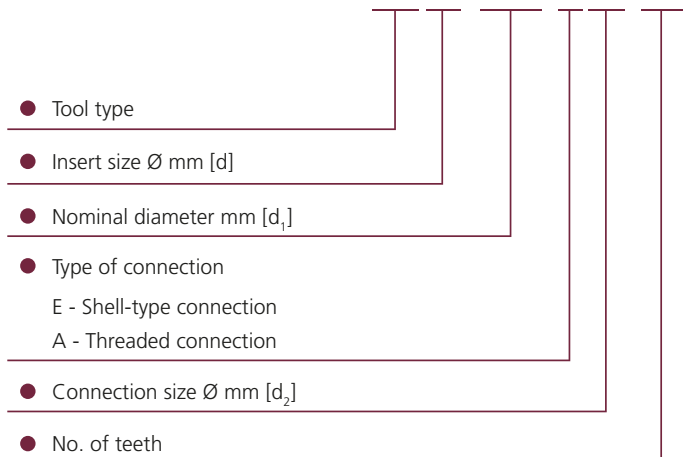

Inserts: **DR 10 - 8 C 4**

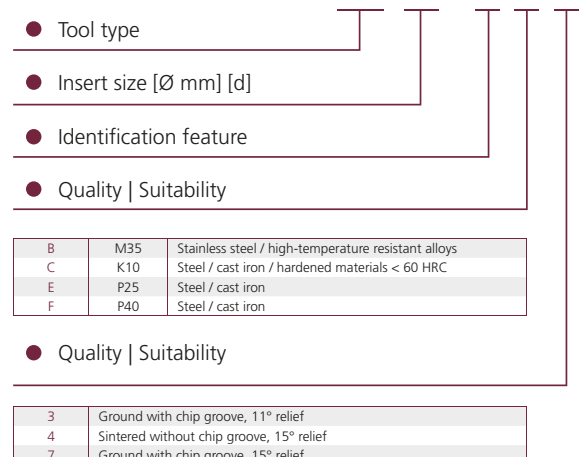

SPINWORX®

r3.5 - Ø 16 - 35 mm, 7° positive



Characteristics:

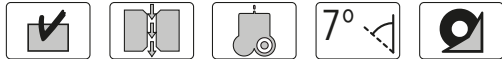

Milling cutter bodies	Part no.	d ₁	d	r	l ₃	l ₂	l ₁	d ₂	d ₃	z
-----------------------	----------	----------------	---	---	----------------	----------------	----------------	----------------	----------------	---

Threaded shank end mill body

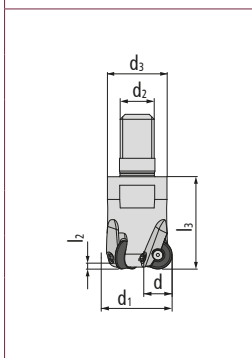

DR07-016-E08-02	16	7	3.5	28.5	1.2	–	M 8	13.8	2
DR07-020-E10-05	20	7	3.5	28.5	1.2	–	M 10	18	5
DR07-025-E12-06	25	7	3.5	28.5	1.2	–	M 12	21	6
DR07-030-E12-07	30	7	3.5	28.5	1.2	–	M 12	21	7
DR07-035-E16-08	35	7	3.5	28.5	1.2	–	M 16	29	8

The accessories shown here must be used for all sizes!

Accessories

SG25	TORQUE CliX-S grip	> Page 199
TG55	TORQUE CliX-T grip	> Page 199
DM04	Torque adapter 0.4 Nm	> Page 199
T06-R	6-pack bits (Torx)	> Page 200
Z 00043	HTC ceramic paste WS 600 005	> Page 200

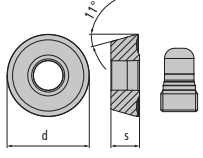
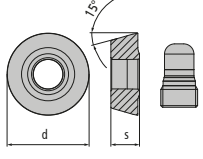
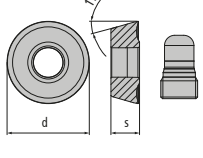
Indexable inserts	Part no.	DIN designation	Quality	Coating	d	s	r	M
	DR07-8B3	RORM 0727 M0EN	B3	–	7	2.7	3.5	–
	DR07-8C4	RDRA 0727 M0SN	C4	–	7	2.7	3.5	–
	DR07-8E4	RDRA 0727 M0SN	E4	–	7	2.7	3.5	–
	DR07-8F4	RDRA 0727 M0SN	F4	–	7	2.7	3.5	–
	DR07-8B7	RDRM 0727 M0EN	B7	–	7	2.7	3.5	–
								

Application data (fz / ap)

Material							
Coating grade	Feed rate/ Depth of cut	Steel	Stainless steel	Cast iron	NF metal and non-metals	High-temperature resistant alloys	Hardened materials
B3	f _z (mm) a _p (mm)	–	0.1-0.5 0.1-0.75	–	–	0.1-0.4 0.1-1	–
C4	f _z (mm) a _p (mm)	0.1-0.4 0.1-0.5	–	0.1-0.3 0.1-0.7	–	–	0.1-0.15 0.1-0.2
E4	f _z (mm) a _p (mm)	0.1-0.4 0.1-0.5	–	0.1-0.3 0.1-0.4	–	–	–
F4	f _z (mm) a _p (mm)	0.1-0.5 0.1-0.8	–	0.1-0.3 0.1-0.7	–	–	–
B7	f _z (mm) a _p (mm)	–	0.1-0.5 0.1-0.75	–	–	0.1-0.4 0.1-1	–

Spindle speed (Vc in m/min)

Material							
Coating grade	Application	Steel	Stainless steel	Cast iron	NF metal and non-metals	High-temperature resistant alloys	Hardened materials
B3	Roughing Semi-Finish Finish	–	▽110 155 200 ▽120 175 230 –	–	–	▽30 65 100 ▽40 75 110 –	–
C4	Roughing Semi-Finish Finish	▽90 150 210 ▽110 165 220 –	–	▽150 195 240 ▽140 205 270 –	–	–	– ▽35 108 180 –
E4	Roughing Semi-Finish Finish	▽100 175 250 ▽100 200 300 –	–	▽130 165 200 –	–	–	–
F4	Roughing Semi-Finish Finish	▽100 175 250 ▽100 200 300 –	–	▽110 130 150 ▽140 180 220 –	–	–	–
B7	Roughing Semi-Finish Finish	–	▽110 155 200 ▽120 175 230 –	–	–	▽30 65 100 ▽40 75 110 –	–

Expanded application data

Full axial plunge		Full oblique plunge			Circular milling		
Arbor Ø d1	X _{max} mm	Arbor Ø d1	α°	y mm	Arbor Ø d1	D _{min} mm	D _{max} mm
16-35	1.2	16	<16.0	4	16	20	30
		20	<8.5	8	20	28	38
		25	<5.0	13	25	38	48
		30	<3.5	18	30	48	58
		35	<3.0	23	35	58	68

SPINWORX®

r5 - Ø 20 - 52 mm, 7° positive



Characteristics:

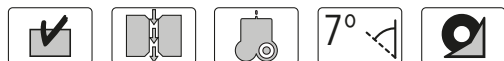

Milling cutter bodies	Part no.	d ₁	d	r	l ₃	l ₂	l ₁	d ₂	d ₃	z
-----------------------	----------	----------------	---	---	----------------	----------------	----------------	----------------	----------------	---

Threaded shank end mill body

	DR10-020-E10-02	20	10	5	29	2.5	–	M 10	18	2
	DR10-025-E12-03	25	10	5	32.5	1.5	–	M 12	21	3
	DR10-025-E12-04	25	10	5	32.5	1.5	–	M 12	21	4
	DR10-030-E12-04	30	10	5	33	2.5	–	M 12	21	4
	DR10-030-E16-04	30	10	5	43	2.5	–	M 16	29	4
	DR10-032-E16-04	32	10	5	43	2.5	–	M 16	29	4
	DR10-032-E16-05	32	10	5	43	2.5	–	M 16	29	5
	DR10-035-E16-05	35	10	5	43	2.5	–	M 16	29	5
	DR10-035-E16-06	35	10	5	43	2.5	–	M 16	29	5
	DR10-042-E16-06	42	10	5	43	2.5	–	M 16	29	6

Shell-type milling cutter body

	DR10-040-A16-05	40	10	5	43	2.5	–	16	35	5
	DR10-042-A16-05	42	10	5	43	2.5	–	16	35	5
	DR10-042-A16-06	42	10	5	43	2.5	–	16	35	6
	DR10-050-A22-07	50	10	5	52	2.5	–	22	40	7
	DR10-052-A22-07	52	10	5	52	2.5	–	22	40	7
	DR10-052-A22-08	52	10	5	52	2.5	–	22	40	8

The accessories shown here must be used for all sizes!

Accessories

SG25	TORQUE CLIX-S grip	> Page 199
TG55	TORQUE CLIX-T grip	> Page 199
DM10	Torque adapter 1.0 Nm	> Page 199
T10-R	6-pack bits (Torx)	> Page 200
Z 00043	HTC ceramic paste WS 600 005	> Page 200

Indexable inserts	Part no.	DIN designation	Quality	Coating	d	s	r	M
	DR10-8B3	RORM 1035 M0EN	B3	–	10	3.5	5	–
	DR10-8C4	RDRA 1035 M0SN	C4	–	10	3.5	5	–
	DR10-8E4	RDRA 1035 M0SN	E4	–	10	3.5	5	–
	DR10-8F4	RDRA 1035 M0SN	F4	–	10	3.5	5	–
	DR10-8B7	RDRM 1035 M0EN	B7	–	10	3.5	5	–
	DR10-80B7	RDRM 1035 M0EN	B7	–	10	3.5	5	–

Application data (fz / ap)

Material							
Coating grade	Feed rate/ Depth of cut	Steel	Stainless steel	Cast iron	NF metal and non-metals	High-temperature resistant alloys	Hardened materials
B3	f _z (mm) a _p (mm)	–	0.15-0.6 0.2-2	–	–	0.1-0.4 0.15-2	–
C4	f _z (mm) a _p (mm)	0.1-0.45 0.2-1	–	0.15-0.35 0.1-1	–	–	0.1-0.15 0.1-0.3
E4	f _z (mm) a _p (mm)	0.1-0.45 0.2-1	–	0.15-0.25 0.1-0.55	–	–	–
F4	f _z (mm) a _p (mm)	0.1-0.5 0.2-1.5	–	0.15-0.35 0.1-1	–	–	–
B7	f _z (mm) a _p (mm)	–	0.15-0.6 0.2-2	–	–	0.1-0.4 0.15-2	–

Spindle speed (Vc in m/min)

Material							
Coating grade	Application	Steel	Stainless steel	Cast iron	NF metal and non-metals	High-temperature resistant alloys	Hardened materials
B3	Roughing Semi-Finish Finish	–	▽110 155 200 ▽120 175 230 –	–	–	▽30 65 100 ▽40 75 110 –	–
C4	Roughing Semi-Finish Finish	▽90 150 210 ▽110 165 220 –	–	▽150 195 240 ▽140 205 270 –	–	–	– ▽35 108 180 –
E4	Roughing Semi-Finish Finish	▽100 175 250 ▽100 200 300 –	–	– ▽130 165 200 –	–	–	–
F4	Roughing Semi-Finish Finish	▽100 175 250 ▽100 200 300 –	–	▽110 130 150 ▽140 180 220 –	–	–	–
B7	Roughing Semi-Finish Finish	–	▽110 155 200 ▽120 175 230 –	–	–	▽30 65 100 ▽40 75 110 –	–

Expanded application data

Full axial plunge	
Arbor Ø d1	X _{max} mm
20-52	2.5

Full oblique plunge		
Arbor Ø d1	α°	y mm
20	<17.0	2
25	<19.5	7
30	<11.5	12
32	<10.0	14
35	<8.0	17
40	<6.0	22
42	<5.5	24
52	<4.0	34

Circular milling		
Arbor Ø d1	D _{min} mm	D _{max} mm
20	22	38
25	32	48
30	42	58
32	46	62
35	52	68
40	62	78
42	66	82
52	86	102



SPINWORX®

r6 - Ø 24 - 100 mm, 7° positive



Characteristics:

Milling cutter bodies	Part no.	d ₁	d	r	l ₃	l ₂	l ₁	d ₂	d ₃	z
-----------------------	----------	----------------	---	---	----------------	----------------	----------------	----------------	----------------	---

Threaded shank end mill body

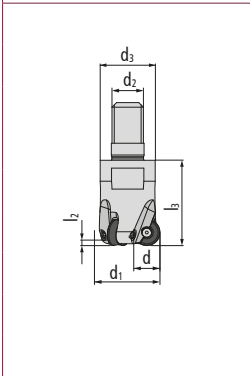

DR12-024-E12-02	24	12	6	33	2.8	-	M 12	21	2
DR12-032-E16-04	32	12	6	42.5	2.8	-	M 16	29	4
DR12-035-E16-03	35	12	6	42.5	2.8	-	M 16	29	3
DR12-035-E16-04	35	12	6	42.5	2.8	-	M 16	29	4
DR12-035-E16-05	35	12	6	42.5	2.8	-	M 16	29	5

Shell-type milling cutter body

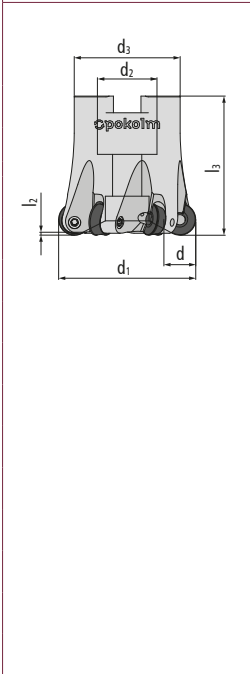

DR12-040-A16-05	40	12	6	42.5	2.8	-	16	35	5
DR12-040-A16-06	40	12	6	42.5	2.8	-	16	35	6
DR12-042-A16-05	42	12	6	42.5	2.8	-	16	35	5

Accessories GWSTPS8ISK Setscrew with hexagon socket > Page 198

DR12-050-A22-06	50	12	6	52.5	2.8	-	22	40	6
DR12-050-A22-07	50	12	6	52.5	2.8	-	22	40	7
DR12-052-A22-06	52	12	6	52.5	2.8	-	22	40	6
DR12-052-A22-07	52	12	6	52.5	2.8	-	22	40	7
DR12-063-A27-06	63	12	6	52.5	2.8	-	27	48	6
DR12-066-A27-07	66	12	6	52.5	2.8	-	27	48	7
DR12-066-A27-08	66	12	6	52.5	2.8	-	27	48	8
DR12-066-A27-09	66	12	6	52.5	2.8	-	27	48	9
DR12-080-A27-08	80	12	6	52.5	2.8	-	27	60	8
DR12-080-A27-09	80	12	6	52.5	2.8	-	27	60	9
DR12-080-A27-10	80	12	6	52.5	2.8	-	27	48	10
DR12-100-A32-10	100	12	6	63	2.8	-	32	70	10

The accessories shown here must be used for all sizes!

Accessories	SG25	TORQUE CliX-S grip	> Page 199
	TG55	TORQUE CliX-T grip	> Page 199
	DM10	Torque adapter 1.0 Nm	> Page 199
	T10-R	6-pack bits (Torx)	> Page 200
	Z 00043	HTC ceramic paste WS 600 005	> Page 200

Indexable inserts	Part no.	DIN designation	Quality	Coating	d	s	r	M
	DR12-8B3	RORM 1245 M0EN	B3	–	12	4.5	6	–
	DR12-8C4	RDRA 1245 M0SN	C4	–	12	4.5	6	–
	DR12-8E4	RDRA 1245 M0SN	E4	–	12	4.5	6	–
	DR12-8F4	RDRA 1245 M0SN	F4	–	12	4.5	6	–
	DR12-8B7	RDRM 1245 M0EN	B7	–	12	4.5	6	–
	DR12-80B7	RDRM 1245 M0SN	B7	–	12	4.5	6	–

Application data (fz / ap)

Material							
Coating grade	Feed rate/ Depth of cut	Steel	Stainless steel	Cast iron	NF metal and non-metals	High-temperature resistant alloys	Hardened materials
B3	f _z (mm) a _p (mm)	–	0.2-0.65 0.3-2.5	–	–	0.1-0.5 0.2-2.5	–
C4	f _z (mm) a _p (mm)	0.1-0.5 0.2-1.5	–	0.15-0.4 0.1-1.5	–	–	0.1-0.18 0.1-0.4
E4	f _z (mm) a _p (mm)	0.1-0.5 0.2-1.5	–	0.15-0.3 0.1-0.8	–	–	–
F4	f _z (mm) a _p (mm)	0.1-0.6 0.2-2	–	0.15-0.4 0.1-1.5	–	–	–
B7	f _z (mm) a _p (mm)	–	0.2-0.65 0.3-2.5	–	–	0.1-0.5 0.2-2.5	–
80B7	f _z (mm) a _p (mm)	–	0.2-0.65 0.3-2.5	–	–	0.1-0.5 0.2-2.5	–

Spindle speed (Vc in m/min)

Material							
Coating grade	Application	Steel	Stainless steel	Cast iron	NF metal and non-metals	High-temperature resistant alloys	Hardened materials
B3	Roughing Semi-Finish Finish	–	▽110 155 200 ▽120 175 230 –	–	–	▽30 65 100 ▽40 75 110 –	–
C4	Roughing Semi-Finish Finish	▽150 180 210 ▽110 165 220 –	–	▽150 195 240 ▽140 205 270 –	–	–	– ▽35 108 180 –
E4	Roughing Semi-Finish Finish	▽100 175 250 ▽100 200 300 –	–	▽130 165 200 –	–	–	–
F4	Roughing Semi-Finish Finish	▽100 175 250 ▽100 200 300 –	–	▽110 130 150 ▽140 180 220 –	–	–	–
B7	Roughing Semi-Finish Finish	–	▽110 155 200 ▽120 175 230 –	–	–	▽30 65 100 ▽40 75 110 –	–
80B7	Roughing Semi-Finish Finish	–	▽110 155 200 ▽120 175 230 –	–	–	▽30 65 100 ▽40 75 110 –	–

Expanded application data

Full axial plunge

Arbor Ø d1	X _{max} mm
24-100	2.8

Full oblique plunge

Arbor Ø d1	α°	y mm
24	<19	2
32	<15.5	10
35	<12.0	13
40	<8.5	18
42	<7.5	20
50	<5.5	28
52	<5.0	30
63	<3.5	41
66	<3.5	44
80	<2	58
100	<2	78

Circular milling

Arbor Ø d1	D _{min} mm	D _{max} mm
24	26	46
32	42	62
35	48	68
40	58	78
42	62	82
50	78	98
52	82	102
63	104	124
66	110	130
80	138	158
100	178	198



SPINWORX®

r8 - Ø 32 - 125 mm, 7° positive



Characteristics:

Milling cutter bodies	Part no.	d ₁	d	r	l ₃	l ₂	l ₁	d ₂	d ₃	z
-----------------------	----------	----------------	---	---	----------------	----------------	----------------	----------------	----------------	---

Threaded shank end mill body										
	DR16-032-E16-02	32	16	8	43.5	3.8	–	M 16	29	2
	DR16-040-E16-04	40	16	8	43.5	2.5	–	M 16	29	4

Shell-type milling cutter body											
	DR16-052-A22-05	52	16	8	53	2.5	–	22	40	5	
	DR16-052-A22-06	52	16	8	53	2.5	–	22	40	6	
	Accessories	GWSTPS10ISK		Setscrew with hexagon socket				> Page 198			
	DR16-063-A27-06	63	16	8	53	2.5	–	27	48	6	
	DR16-066-A27-06	66	16	8	53	2.5	–	27	48	6	
	DR16-080-A27-07	80	16	8	53	2.5	–	27	60	7	
DR16-100-A32-08	100	16	8	53	2.5	–	32	70	8		
DR16-125-A40-09	125	16	8	53	2.5	–	40	90	9		
Accessories	M16X35		Cheese-head screw hexagon socket low head				> Page 197				

<p>The accessories shown here must be used for all sizes!</p>	<p>Accessories</p>	SG25	TORQUE CliX-S grip	> Page 199
		TG55	TORQUE CliX-T grip	> Page 199
		DM22	Torque adapter 2.2 Nm	> Page 199
		T20-R	6-pack bits (Torx)	> Page 200
		Z 00043	HTC ceramic paste WS 600 005	> Page 200

Indexable inserts	Part no.	DIN designation	Quality	Coating	d	s	r	M
	DR16-8B3	RORM 1655 M0EN	B3	–	16	5.5	8	–
	DR16-8C4	RDRA 1655 M0SN	C4	–	16	5.5	8	–
	DR16-8E4	RDRA 1655 M0SN	E4	–	16	5.5	8	–
	DR16-8F4	RDRA 1655 M0SN	F4	–	16	5.5	8	–
	DR16-8B7	RDRM 1655 M0EN	B7	–	16	5.5	8	–

Application data (f_z / a_p)

Material							
Coating grade	Feed rate/ Depth of cut	Steel	Stainless steel	Cast iron	NF metal and non-metals	High-temperature resistant alloys	Hardened materials
B3	f _z (mm) a _p (mm)	–	0.2-0.7 0.5-3	–	–	0.15-0.5 0.2-3	–
C4	f _z (mm) a _p (mm)	0.2-0.7 0.2-2.5	–	0.2-0.5 0.2-3	–	–	0.15-0.22 0.2-0.55
E4	f _z (mm) a _p (mm)	0.2-0.7 0.2-2.5	–	0.2-0.35 0.2-1.6	–	–	–
F4	f _z (mm) a _p (mm)	0.2-0.8 0.2-3	–	0.2-0.5 0.2-3	–	–	–
B7	f _z (mm) a _p (mm)	–	0.2-0.7 0.5-3	–	–	0.15-0.5 0.2-3	–

Spindle speed (Vc in m/min)

Material							
Coating grade	Application	Steel	Stainless steel	Cast iron	NF metal and non-metals	High-temperature resistant alloys	Hardened materials
B3	Roughing Semi-Finish Finish	–	▽110 155 200 ▽120 175 230 –	–	–	▽30 65 100 ▽40 75 110 –	–
C4	Roughing Semi-Finish Finish	▽90 150 210 ▽110 165 220 –	–	▽150 195 240 ▽140 205 270 –	–	–	– ▽35 108 180 –
E4	Roughing Semi-Finish Finish	▽100 175 250 ▽100 200 300 –	–	– ▽130 165 200 –	–	–	–
F4	Roughing Semi-Finish Finish	▽100 175 250 ▽100 200 300 –	–	▽110 130 150 ▽140 180 220 –	–	–	–
B7	Roughing Semi-Finish Finish	–	▽110 155 200 ▽120 175 230 –	–	–	▽30 65 100 ▽40 75 110 –	–

Expanded application data

Full axial plunge

Arbor Ø d1	X _{max} mm
32-125	2.5

Full oblique plunge

Arbor Ø d1	α°	y mm
32	<20	2
40	<14.0	10
52	<6.0	22
63	<4.0	33
66	<3.5	36
80	<2.5	50
100	<2.0	70
125	<1.5	95

Circular milling

Arbor Ø d1	D _{min} mm	D _{max} mm
32	34	62
40	50	78
52	74	102
63	96	124
66	102	130
80	130	158
100	170	198
125	220	248



SPINWORX®

r10 - Ø 100 - 160 mm, 7° positive

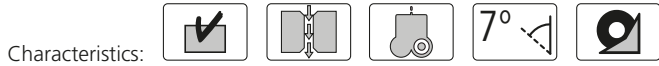

Milling cutter bodies	Part no.	d ₁	d	r	l ₃	l ₂	l ₁	d ₂	d ₃	z	
Shell-type milling cutter body											
	DR20-100-A32-07-L	100	20	10	53	4	–	32	70	7	
	DR20-125-A40-08-L	125	20	10	53	4	–	40	90	8	
	Accessories	GWSTPS10ISK	Setscrew with hexagon socket							> Page 198	
		SG25	TORQUE CliX-S grip							> Page 199	
		TG55	TORQUE CliX-T grip							> Page 199	
		DM22	Torque adapter 2.2 Nm							> Page 199	
		T20-R	6-pack bits (Torx)							> Page 200	
	Z 00043	HTC ceramic paste WS 600 005							> Page 200		
	DR20-160-A40-10-L	160	20	10	53	4	–	40	120	10	
	Accessories	SG25	TORQUE CliX-S grip							> Page 199	
TG55		TORQUE CliX-T grip							> Page 199		
DM22		Torque adapter 2.2 Nm							> Page 199		
T20-R		6-pack bits (Torx)							> Page 200		
Z 00043		HTC ceramic paste WS 600 005							> Page 200		

Indexable inserts	Part no.	DIN designation	Quality	Coating	d	s	r	M
	DR20-8C4-L	RDRA 2065 M0SN	C4	–	20	6.5	10	–
	DR20-8E4-L	RDRA 2065 M0SN	E4	–	20	6.5	10	–
	DR20-8F4-L	RDRA 2065 M0SN	F4	–	20	6.5	10	–

Application data (f_z / a_p)

Material							
Coating grade	Feed rate/ Depth of cut	Steel	Stainless steel	Cast iron	NF metal and non-metals	High-temperature resistant alloys	Hardened materials
C4	f _z (mm) a _p (mm)	0.2-0.7 0.2-2.5	–	0.2-0.5 0.2-3	–	–	0.15-0.23 0.2-0.55
E4	f _z (mm) a _p (mm)	0.2-0.7 0.2-2.5	–	0.2-0.35 0.2-1.6	–	–	–
F4	f _z (mm) a _p (mm)	0.2-0.8 0.2-3	–	0.2-0.5 0.2-3	–	–	–

Spindle speed (Vc in m/min)

Material							
Coating grade	Application	Steel	Stainless steel	Cast iron	NF metal and non-metals	High-temperature resistant alloys	Hardened materials
C4	Roughing Semi-Finish Finish	▽90 150 210	-	▽150 195 240	-	-	-
		▽110 165 220		▽140 205 270			▽35 108 180
E4	Roughing Semi-Finish Finish	▽100 175 250	-	-	-	-	-
		▽100 200 300		▽130 165 200			-
F4	Roughing Semi-Finish Finish	▽100 175 250	-	▽110 130 150	-	-	-
		▽100 200 300		▽140 180 220			-

Expanded application data

Full axial plunge		Full oblique plunge			Circular milling		
Arbor Ø d1	X _{max} mm	Arbor Ø d1	α°	y mm	Arbor Ø d1	D _{min} mm	D _{max} mm
100	2.0	100	<4.6	62	100	162	200
125-160	3.0	125	<3.3	87	125	212	250
		160	<2.3	122	160	282	320



Round insert
cutters K0-90°

OKOIM
made in Germany

Round insert cutters K0-90° Copy end mills

The universal choice for any job, from the regular to the unusual



Properties

- Tool diameter 8 - 160 mm
- 0° axial angle for the most precise contours in combination with DuoPlug® maximum stability
- 7° axial angle ensures low power consumption
- stable tool cutter body thanks to indexable insert embedding
- 8 different cemented carbide qualities with 9 adapted high-performance coatings
- Cutter bodies with the addendum VD have special vibration-damping properties

Sizes	Page
r 3.5 - Ø 12 - 25 mm, s 1.99	84
r 3.5 - Ø 15 - 42 mm, s 238	86
r 5 - Ø 20 - 42 mm, neutral	91
r 5 - Ø 25 - 52 mm, 7° positive	96
r 5 - Ø 20 - 35 mm, CBN, neutral	101
r 6 - Ø 42 - 80 mm, 7° positive, shim	103
r 6 - Ø 24 - 80 mm, neutral, 7° positive	107
r 8 - Ø 52 - 100 mm, 7° positive, shim	112
r 8 - Ø 32 - 160 mm, neutral 7° positive	115
r 10 - Ø 40 - 160 mm, neutral 7° positive	119

Machining types

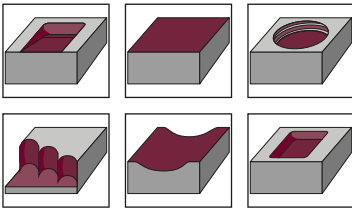

Connection types

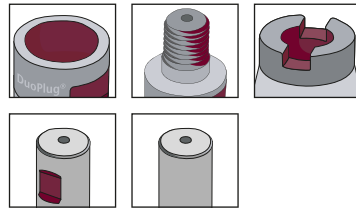

Practical video
ROUND INSERT 02 10
896 IN 1.4301 / 304 /
X5CRNi18-10



Cutting materials

Quality coating	ISO application						7 - 1.99	7 - 2.38	10	12	16	20
	P	M	K	N	S	H						
HSC05 PVTi; HSC05 PVFN	▽	▽	▽	▽	-	▽	•	•	•	•	•	•
K10 PVTi	▽	▽	▽	-	▽	▽	•	•	•	•	•	•
K10 PVTi (RDHX with concave molding)	-	▽	-	▽	▽	-	•	•	•	•	•	-
P25 PVTi	▽	-	▽	-	-	-	-	•	•	•	•	•
P25 PVGO	-	▽	-	-	▽	-	-	•	•	•	•	-
P25 PVSR	▽	-	▽	-	-	▽	-	-	•	•	•	-
P40 PVTi	▽	-	-	-	-	-	•	•	•	•	•	•
P40 PVGO	▽	-	▽	-	-	-	-	•	•	•	•	-
P40 PVSR	▽	-	▽	-	-	▽	•	•	•	•	•	-
P40 PVML	▽	-	▽	-	-	▽	-	•	•	•	•	-
CBN C	-	-	▽	-	-	-	-	-	•	-	-	-
CBN S	-	-	-	-	-	▽	-	•	•	-	-	-
K10 Polished	-	-	-	▽	-	-	•	•	•	•	•	•
K10 PVDiaN	-	-	-	▽	-	-	•	•	•	•	-	-
M40 PVST	▽	▽	-	-	▽	-	-	-	•	•	-	-
HSC03 PPGH	▽	▽	▽	-	-	▽	-	•	•	•	-	-
M35 PCTC	-	▽	-	-	▽	-	-	•	•	•	•	-

Round insert cutters K0-90°

r3.5 - Ø 12 - 25 mm, s 1.99 mm



Characteristics:

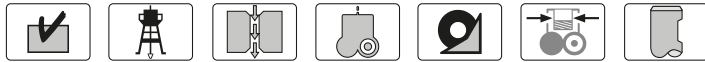

Milling cutter bodies	Part no.	d ₁	d	r	l ₃	l ₂	l ₁	d ₂	d ₃	z
-----------------------	----------	----------------	---	---	----------------	----------------	----------------	----------------	----------------	---

DuoPlug®										
	2 12 235 SG	12	7	3.5	24.5	–	–	M 7	10.8	2
	Accessories	25 500 K-1		Torx screw		> Page 197				
	3 15 235 SG	15	7	3.5	28	1.5	–	M 10	14	3
	5 25 235 SG	25	7	3.5	30	1.5	–	M 16	23.5	5
	Accessories	25 500		Torx screw		> Page 197				

Threaded shank end mill body										
	12 200 M6	12	7	3.5	28.5	–	–	M 6	11.5	2
	12 200	12	7	3.5	28.5	–	–	M 8	11.8	2
	Accessories	25 500 K-1		Torx screw		> Page 197				
	3 15 235	15	7	3.5	28.5	1.5	–	M 8	13.8	3
	4 20 235	20	7	3.5	28.5	1.5	–	M 10	18	4
5 25 235	25	7	3.5	28.5	1.5	–	M 12	21	5	
Accessories	25 500		Torx screw		> Page 197					

End mills										
	30 12 100	12	7	3.5	30	–	23	12	–	2
	Accessories	25 500 K-1		Torx screw		> Page 197				

Milling cutter bodies	Part no.	d_1	d	r	l_3	l_2	l_1	d_2	d_3	z
-----------------------	----------	-------	-----	-----	-------	-------	-------	-------	-------	-----

Weldon										
	40 12 100	12	7	3.5	40	–	19.5	16	–	2
	60 12 100	12	7	3.5	60	–	19.5	16	–	2
	80 12 100	12	7	3.5	80	–	19.5	16	–	2
	Accessories	25 500 K-1		Torx screw		> Page 197				

	30 15 100	15	7	3.5	30	1.2	19.5	12	–	3
--	-----------	----	---	-----	----	-----	------	----	---	---

The accessories shown here must be used for all sizes!	Accessories	07 500	Torx wrench	> Page 198
		SG25	TORQUE CLIX-S grip	> Page 199
		TG55	TORQUE CLIX-T grip	> Page 199
		DM09	Torque adapter 0.9 Nm	> Page 199
		T07-R	6-pack bits (Torx)	> Page 200

<2/2

Indexable inserts	Part no.	DIN designation	Quality	Coating	d	s	r	M
-------------------	----------	-----------------	---------	---------	-----	-----	-----	-----

	01 07 8035	RDHX 07T1 M0T	HSC 05	PVTi	7	1.99	3.5	M 2.5
	01 07 8042	RDEX 07T1 M0T	P40	PCSR	7	1.99	3.5	M 2.5

	01 07 831 P	RDHX 07T1 M0E	K10	Polished	7	1.99	3.5	M 2.5
	01 07 880 D	RDHX 07T1 M0E	K10	PVDiaN	7	1.99	3.5	M 2.5
	01 07 880	RDHX 07T1 M0E	K10	PVTi	7	1.99	3.5	M 2.5

Application data (f_z / a_p)

Material							
Coating grade	Feed rate/ Depth of cut	Steel	Stainless steel	Cast iron	NF metal and non-metals	High-temperature resistant alloys	Hardened materials
K10 PVTi	f_z (mm) a_p (mm)	0.1-0.2 0.1-0.3	0.1 0.1	0.1-0.3 0.1-0.5	0.1-0.2 0.1-0.4	–	0.1-0.12 0.1-0.15
P40 PCSR	f_z (mm) a_p (mm)	0.05-0.45 0.05-0.7	–	0.1-0.4 0.05-0.65	–	–	–
K10 Polished	f_z (mm) a_p (mm)	–	–	–	0.1-0.3 0.1-0.7	–	–
K10 PVDiaN	f_z (mm) a_p (mm)	–	–	–	0.1-0.3 0.1-0.7	–	–

Spindle speed (Vc in m/min)

Material							
Coating grade	Application	Steel	Stainless steel	Cast iron	NF metal and non-metals	High-temperature resistant alloys	Hardened materials
K10 PVTi	Roughing	–	–	▽100 150 200	–	–	–
	Semi-Finish	▽150 275 400	–	▽150 225 300	▽200 500 800	–	▽35 143 250
P40 PCSR	Finish	▽150 275 400	▽100 150 200	▽200 275 350	▽100 450 800	–	▽35 143 250
	Roughing	▽130 190 250	–	▽120 170 220	–	–	–
K10 Polished	Semi-Finish	▽150 225 300	–	▽150 200 250	–	–	–
	Finish	–	–	▽180 230 280	–	–	–
K10 PVDiaN	Roughing	–	–	–	▽100 450 800	–	–
	Semi-Finish	–	–	–	▽100 450 800	–	–
	Finish	–	–	–	▽100 450 800	–	–

Expanded application data

Full axial plunge

Arbor Ø d1	X _{max} mm
12-25	1.2

Full oblique plunge

Arbor Ø d1	α°	y mm
12	–	–
15	<26.5	2
20	<8.5	8
25	<5.3	13

Circular milling

Arbor Ø d1	D _{min} mm	D _{max} mm
12	14	24
15	17	30
20	28	40
25	38	50

Round insert cutters K0-90°

r3.5 - Ø 15 - 42 mm, s 2.38 mm



Characteristics:



Milling cutter bodies	Part no.	d_1	d	r	l_3	l_2	l_1	d_2	d_3	z
-----------------------	----------	-------	-----	-----	-------	-------	-------	-------	-------	-----

DuoPlug®

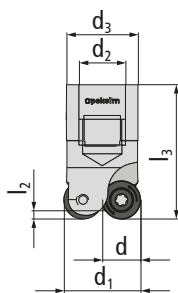

2 16 200 SG	16	7	3.5	28.5	1.5	-	M 10	15	2
3 16 200 SG	16	7	3.5	28.5	1.5	-	M 10	15	3
4 20 200 SG	20	7	3.5	28.5	1.5	-	M 12	18.6	4
5 25 200 SG	25	7	3.5	30	1.5	-	M 16	23.5	5

Threaded shank end mill body

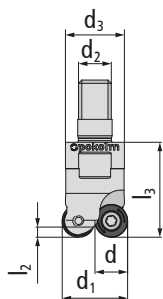

15 200	15	7	3.5	28.5	1.5	-	M 8	13.8	2
3 16 200	16	7	3.5	28.5	1.5	-	M 8	13.8	3
4 20 200	20	7	3.5	28.5	1.5	-	M 10	18	4
5 25 200	25	7	3.5	28.5	1.5	-	M 12	21	5
5 30 200	30	7	3.5	28.5	1.5	-	M 16	29	5
6 35 200	35	7	3.5	28.5	1.5	-	M 16	29	6
7 42 200	42	7	3.5	42.5	1.5	-	M 16	29	7

Weldon

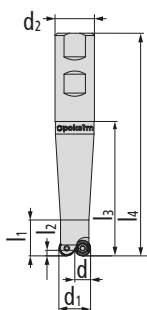

40 15 100	15	7	3.5	40	2.6	23	16	-	2
60 15 100	15	7	3.5	60	2.6	23	16	-	2
80 15 100	15	7	3.5	80	2.6	22	20	-	2
100 15 100	15	7	3.5	100	2.6	22	20	-	2

The accessories shown here must be used for all sizes!

Accessories

25 500	Torx screw	> Page 197
07 500	Torx wrench	> Page 198
SG25	TORQUE CliX-S grip	> Page 199
TG55	TORQUE CliX-T grip	> Page 199
DM09	Torque adapter 0.9 Nm	> Page 199
T07-R	6-pack bits (Torx)	> Page 200

ROUND INSERT CUTTERS – COPY END MILLS

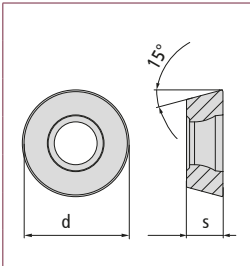
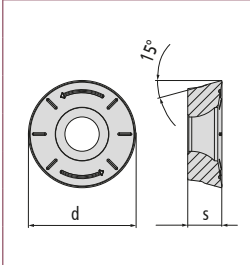
Indexable inserts	Part no.	DIN designation	Quality	Coating	d	s	r	M
	02 07 8035	RDHX 0702 M0T	HSC 05	PVTi	7	2.38	3.5	M 2.5
	02 07 8042	RDEX 0702 M0T	P40	PCSR	7	2.38	3.5	M 2.5
	02 07 846	RDKW 0702 MOS	P40	PVGO	7	2.38	3.5	M 2.5
	02 07 892	RDHX 0702 M0T	CBN for steel	uncoated	7	2.38	3.5	M 2.5
	02 07 848	RDMX 0702 M0T	P40	PVGO	7	2.38	3.5	M 2.5
	02 07 831P	RDHX 0702 M0E	K10	Polished	7	2.38	3.5	M 2.5
	02 07 880	RDHX 0702 M0E	K10	PVTi	7	2.38	3.5	M 2.5
	02 07 880 D	RDHX 0702 M0E	K10	PVDiaN	7	2.38	3.5	M 2.5
	02 07 896	RDMT 0702 M0EN	M40	PVST	7	2.38	3.5	M 2.5
	02 07 8099	RDMT 0702 M0EN	M35	PCTC	7	2.38	3.5	M 2.5
	02 07 897	RDPX 0702 M0T	P25	PVGO	7	2.38	3.5	M 2.5

Application data (fz / ap)

Material							
Coating grade	Feed rate/ Depth of cut	Steel	Stainless steel	Cast iron	NF metal and non- metals	High-temperature resistant alloys	Hardened materials
K10 PVTi	f _z (mm) a _p (mm)	0.1-0.2 0.1-0.4	0.1 0.1	0.1-0.3 0.1-0.7	0.1-0.2 0.1-0.55	-	0.1-0.15 0.1-0.2
P40 PVTi	f _z (mm) a _p (mm)	0.2-0.5 0.1-0.75	-	-	-	-	-
P40 PCSR	f _z (mm) a _p (mm)	0.1-0.5 0.1-0.75	-	0.1-0.4 0.1-0.7	-	-	-
P40 PVGO	f _z (mm) a _p (mm)	0.2-0.5 0.1-0.75	-	-	-	-	-
CBN for steel uncoated	f _z (mm) a _p (mm)	-	-	-	-	-	0.1-0.2 0.1
K10 Polished	f _z (mm) a _p (mm)	-	-	-	0.1-0.3 0.1-1	-	-
K10 PVDiaN	f _z (mm) a _p (mm)	-	-	-	0.1-0.3 0.1-1	-	-
M40 PVST	f _z (mm) a _p (mm)	0.1-0.5 0.1-0.75	0.05-0.5 0.05-0.75	-	-	0.05-0.4 0.05-0.75	-
M35 PCTC	f _z (mm) a _p (mm)	-	0.05-0.5 0.05-0.75	-	-	0.05-0.4 0.05-0.75	-
P25 PVGO	f _z (mm) a _p (mm)	-	0.1-0.4 0.1-0.7	-	-	0.1-0.3 0.1-0.7	-

Spindle speed (Vc in m/min)

Material							
Coating grade	Application	Steel	Stainless steel	Cast iron	NF metal and non-metals	High-temperature resistant alloys	Hardened materials
K10 PVTi	Roughing Semi-Finish Finish	–	–	▽100 150 200	–	–	–
		▽150 275 400 ▽150 275 400	– ▽100 150 200	▽150 225 300 ▽200 275 350	▽200 500 800 ▽100 450 800	–	▽35 143 250 ▽35 143 250
P40 PVTi	Roughing Semi-Finish Finish	▽100 160 220 ▽100 175 250 –	–	–	–	–	–
		–	–	–	–	–	
P40 PCSR	Roughing Semi-Finish Finish	▽130 190 250 ▽150 225 300 –	–	▽120 170 220 ▽150 200 250 ▽180 230 280	–	–	–
		–	–	–	–	–	
P40 PVGO	Roughing Semi-Finish Finish	▽100 150 200 ▽100 150 200 –	–	–	–	–	–
		–	–	–	–	–	
CBN for steel uncoated	Roughing Semi-Finish Finish	–	–	–	–	–	– – ▽400 700 1000
K10 Polished	Roughing Semi-Finish Finish	–	–	–	▽100 450 800 ▽100 450 800 ▽100 450 800	–	–
K10 PVDiaN	Roughing Semi-Finish Finish	–	–	–	▽100 450 800 ▽100 450 800 ▽100 450 800	–	–
M40 PVST	Roughing Semi-Finish Finish	▽80 140 200 ▽100 150 200 ▽110 180 250	▽80 130 180 ▽100 155 210 ▽120 185 250	–	–	▽30 55 80 ▽40 65 90 ▽60 90 120	–
		–	▽110 155 200 ▽120 175 230 ▽160 220 280	–	–	▽30 65 100 ▽40 75 110 ▽60 100 140	–
		–	▽80 140 200 ▽100 155 210 ▽120 175 230	–	–	▽20 65 110 ▽20 65 110 ▽30 70 110	–

Expanded application data

Full axial plunge

Arbor Ø d1	X _{max} mm
15-42	1.2

Full oblique plunge

Arbor Ø d1	α°	y mm
15	<26.5	2
16	<14.0	4
20	<8.5	8
25	<5.3	13
30	<3.8	18
35	<3.0	23
42	<2.3	30

Circular milling

Arbor Ø d1	D _{min} mm	D _{max} mm
15	17	30
16	20	32
20	28	40
25	38	50
30	48	60
35	58	70
42	72	84

Round insert cutters K0-90°

r5 - Ø 20 - 42 mm, neutral



Characteristics:

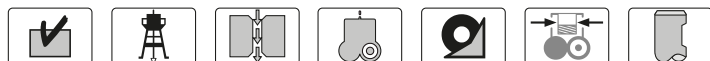

Milling cutter bodies	Part no.	d ₁	d	r	l ₃	l ₂	l ₁	d ₂	d ₃	z
-----------------------	----------	----------------	---	---	----------------	----------------	----------------	----------------	----------------	---

DuoPlug®

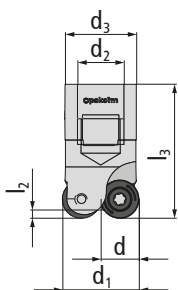

20 200 SG	20	10	5	35	-	-	M 12	18.6	2
3 25 200 SG	25	10	5	35	2.8	-	M 16	23.5	3

Threaded shank end mill body

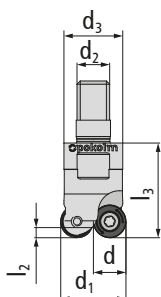

20 200	20	10	5	29	-	-	M 10	18	2
2 25 200	25	10	5	33	2.8	-	M 12	21	2
3 25 200	25	10	5	33	2.8	-	M 12	21	3
4 25 200	25	10	5	33	2.8	-	M 12	21	4
4 30 201	30	10	5	33	2.8	-	M 12	21	4
4 30 200	30	10	5	43	2.8	-	M 16	29	4
5 35 200	35	10	5	43	2.8	-	M 16	29	5
N 5 42 200	42	10	5	43	2.8	-	M 16	29	5
6 42 200	42	10	5	43	2.8	-	M 16	29	6

Weldon

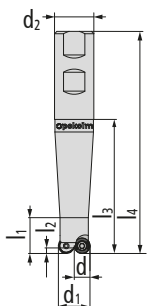

40 20 100	20	10	5	40	-	23	20	-	2
60 20 100	20	10	5	60	-	23	20	-	2
80 20 100	20	10	5	80	-	23	25	-	2
100 20 100	20	10	5	100	-	23	25	-	2
120 20 100	20	10	5	120	-	23	25	-	2

1/2>

ROUND INSERT CUTTERS – COPY END MILLS

Milling cutter bodies	Part no.	d_1	d	r	l_3	l_2	l_1	d_2	d_3	z
-----------------------	----------	-------	-----	-----	-------	-------	-------	-------	-------	-----

Shell-type milling cutter body

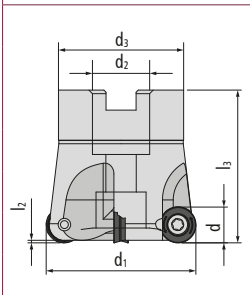

6 42 310	42	10	5	43	2.8	–	16	35	6
----------	----	----	---	----	-----	---	----	----	---

The accessories shown here must be used for all sizes!

Accessories

35 500	Torx screw	> Page 197
15 500	Torx wrench	> Page 198
SG25	TORQUE CliX-S grip	> Page 199
TG55	TORQUE CliX-T grip	> Page 199
DM25	Torque adapter 2.5 Nm	> Page 198
T15-R	6-pack bits (Torx)	> Page 200

<2/2

Indexable inserts	Part no.	DIN designation	Quality	Coating	d	s	r	M
-------------------	----------	-----------------	---------	---------	-----	-----	-----	-----

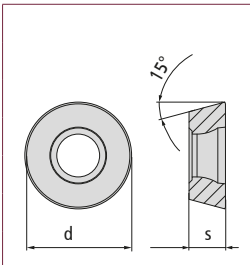

02 10 8035	RDHX 1003 M0T	HSC 05	PVTi	10	3.18	5	M 3.5
02 10 8042	RDEX 1003 M0T	P40	PCSR	10	3.18	5	M 3.5
02 10 844	RDHX 1003 M0T	P40	PVML	10	3.18	5	M 3.5
02 10 846	RDMX 1003 MOSN	P40	PVGO	10	3.18	5	M 3.5
02 10 852	RDEX 1003 M0T	P25	PVSR	10	3.18	5	M 3.5
02 10 892	RDHX 1003 M0T	CBN for steel	uncoated	10	3.18	5	M 3.5
02 10 893	RDHX 1003 M0T	CBN for cast iron	uncoated	10	3.18	5	M 3.5

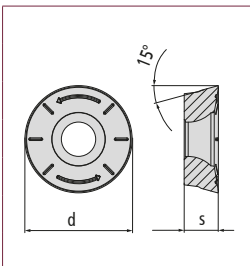

02 10 831P	RDHX 1003 M0T	K10	Polished	10	3.18	5	M 3.5
02 10 848	RDMX 1003 M0T	P40	PVGO	10	3.18	5	M 3.5
02 10 880	RDHX 1003 M0T	K10	PVTi	10	3.18	5	M 3.5
02 10 880 D	RDHX 1003 M0T	K10	PVDiaN	10	3.18	5	M 3.5
02 10 896	RDMT 1003 M0EN	M40	PVST	10	3.18	5	M 3.5
02 10 897	RDPX 1003 M0T	P25	PVGO	10	3.18	5	M 3.5
02 10 8099	RDMT 1003 M0EN	M35	PCTC	10	3.18	5	M 3.5

Application data (fz / ap)

Material							
Coating grade	Feed rate/ Depth of cut	Steel	Stainless steel	Cast iron	NF metal and non-metals	High-temperature resistant alloys	Hardened materials
K10 PVTi	f _z (mm) a _p (mm)	0.1-0.2 0.1-0.55	0.15 0.1	0.15-0.3 0.1-1	0.1-0.2 0.1-0.8	–	0.1-0.15 0.1-0.3
P40 PCSR	f _z (mm) a _p (mm)	0.2-1 0.2-1.5	–	0.1-0.8 0.1-1.2	–	–	–
P40 PVML	f _z (mm) a _p (mm)	0.2-0.7 0.2-1.5	–	0.1-0.3 0.1-1	–	–	0.1-0.15 0.1-0.3
P40 PVGO	f _z (mm) a _p (mm)	0.1-0.9 0.1-1.5	–	0.1-0.3 0.1-1	–	–	–
P25 PVSR	f _z (mm) a _p (mm)	0.2-0.7 0.2-1.5	–	0.1-0.3 0.1-1	–	–	0.1-0.15 0.1-0.3
CBN for steel uncoated	f _z (mm) a _p (mm)	–	–	–	–	–	0.1-0.2 0.1
CBN for cast iron uncoated	f _z (mm) a _p (mm)	–	–	0.1-0.2 0.1	–	–	–
K10 Polished	f _z (mm) a _p (mm)	–	–	–	0.1-0.3 0.1-1.5	–	–
K10 PVDiaN	f _z (mm) a _p (mm)	–	–	–	0.1-0.3 0.1-1.5	–	–
M40 PVST	f _z (mm) a _p (mm)	0.1-0.75 0.1-1	0.05-0.6 0.2-2	–	–	0.05-0.4 0.1-2	–
P25 PVGO	f _z (mm) a _p (mm)	–	0.15-0.6 0.2-1	–	–	0.1-0.4 0.1-1	–
M35 PCTC	f _z (mm) a _p (mm)	–	0.05-0.6 0.2-2	–	–	0.05-0.4 0.1-2	–

Spindle speed (Vc in m/min)

Material							
Coating grade	Application	Steel	Stainless steel	Cast iron	NF metal and non-metals	High-temperature resistant alloys	Hardened materials
K10 PVTi	Roughing	–	–	▽100 150 200	–	–	–
	Semi-Finish	▽150 275 400	–	▽150 225 300	▽200 500 800	–	▽35 143 250
	Finish	▽150 275 400	▽100 150 200	▽200 275 350	▽100 450 800	–	▽35 143 250
P40 PCSR	Roughing	▽130 190 250	–	▽120 170 220	–	–	–
	Semi-Finish	▽150 225 300	–	▽150 200 250	–	–	–
	Finish	–	–	▽180 230 280	–	–	–
P40 PVML	Roughing	▽100 200 300	–	▽140 215 290	–	–	–
	Semi-Finish	▽100 200 300	–	▽140 170 200	–	–	▽70 110 150
	Finish	–	–	–	–	–	–
P40 PVGO	Roughing	▽100 150 200	–	▽110 130 150	–	–	–
	Semi-Finish	▽100 150 200	–	▽110 130 150	–	–	–
	Finish	–	–	–	–	–	–
P25 PVSR	Roughing	▽100 160 220	–	▽140 180 220	–	–	–
	Semi-Finish	▽100 180 260	–	▽160 190 220	–	–	▽70 110 150
	Finish	–	–	▽160 190 220	–	–	–
CBN for steel uncoated	Roughing	–	–	–	–	–	–
	Semi-Finish	–	–	–	–	–	–
	Finish	–	–	–	–	–	▽400 700 1000
CBN for cast iron uncoated	Roughing	–	–	–	–	–	–
	Semi-Finish	–	–	–	–	–	–
	Finish	–	–	▽400 700 1000	–	–	–
K10 Polished	Roughing	–	–	–	▽100 450 800	–	–
	Semi-Finish	–	–	–	▽100 450 800	–	–
	Finish	–	–	–	▽100 450 800	–	–
K10 PVDiaN	Roughing	–	–	–	▽100 450 800	–	–
	Semi-Finish	–	–	–	▽100 450 800	–	–
	Finish	–	–	–	▽100 450 800	–	–
M40 PVST	Roughing	▽80 140 200	▽80 130 180	–	–	▽30 55 80	–
	Semi-Finish	▽100 150 200	▽100 155 210	–	–	▽40 65 90	–
	Finish	▽110 180 250	▽120 185 250	–	–	▽60 90 120	–
P25 PVGO	Roughing	–	▽80 140 200	–	–	▽20 65 110	–
	Semi-Finish	–	▽100 155 210	–	–	▽20 65 110	–
	Finish	–	▽120 175 230	–	–	▽30 70 110	–
M35 PCTC	Roughing	–	▽110 155 200	–	–	▽30 65 100	–
	Semi-Finish	–	▽120 175 230	–	–	▽40 75 110	–
	Finish	–	▽160 220 280	–	–	▽60 100 140	–

Expanded application data

Full axial plunge

Arbor Ø d1	X _{max} mm
20-35	2.5
42	3.5

Full oblique plunge

Arbor Ø d1	α°	y mm
20	–	–
25	<19.7	7
30	<11.7	12
35	<8.4	17
42	<5.9	24

Circular milling

Arbor Ø d1	D _{min} mm	D _{max} mm
20	22	40
25	32	50
30	42	60
35	52	70
42	66	84

Round insert cutters K0-90°

r5 - Ø 25 - 52 mm, 7° positive



Characteristics:

Milling cutter bodies	Part no.	d ₁	d	r	l ₃	l ₂	l ₁	d ₂	d ₃	z
-----------------------	----------	----------------	---	---	----------------	----------------	----------------	----------------	----------------	---

Threaded shank end mill body										
	3 25 200/7	25	10	5	32.5	2.5	–	M 12	21	3
	5 35 200/7	35	10	5	43	2.5	–	M 16	29	5
	6 42 200/7	42	10	5	42.5	2.5	–	M 16	29	6

Shell-type milling cutter body										
	6 42 310/7	42	10	5	42.5	3.5	–	16	35	6
	7 52 310/7	52	10	5	52.5	3.5	–	22	40	7
	6 42 310/7 VD	42	10	5	42.5	3.5	–	16	35	6
	7 52 310/7 VD	52	10	5	52.5	3.5	–	22	40	7

<p>The accessories shown here must be used for all sizes!</p>	<p>Accessories</p>	35 500	Torx screw	> Page 197
		15 500	Torx wrench	> Page 198
		SG25	TORQUE CliX-S grip	> Page 199
		TG55	TORQUE CliX-T grip	> Page 199
		DM25	Torque adapter 2.5 Nm	> Page 199
		T15-R	6-pack bits (Torx)	> Page 200

Indexable inserts	Part no.	DIN designation	Quality	Coating	d	s	r	M
	02 10 8035	RDHX 1003 M0T	HSC 05	PVTi	10	3.18	5	M 3.5
	02 10 8042	RDEX 1003 M0T	P40	PCSR	10	3.18	5	M 3.5
	02 10 844	RDHX 1003 M0T	P40	PVML	10	3.18	5	M 3.5
	02 10 846	RDMX 1003 MOSN	P40	PVGO	10	3.18	5	M 3.5
	02 10 852	RDEX 1003 M0T	P25	PVSR	10	3.18	5	M 3.5
	02 10 892	RDHX 1003 M0T	CBN for steel	uncoated	10	3.18	5	M 3.5
	02 10 893	RDHX 1003 M0T	CBN for cast iron	uncoated	10	3.18	5	M 3.5
	02 10 831P	RDHX 1003 M0T	K10	Polished	10	3.18	5	M 3.5
	02 10 848	RDMX 1003 M0T	P40	PVGO	10	3.18	5	M 3.5
	02 10 880	RDHX 1003 M0T	K10	PVTi	10	3.18	5	M 3.5
	02 10 880 D	RDHX 1003 M0T	K10	PVDiaN	10	3.18	5	M 3.5
	02 10 896	RDMT 1003 M0EN	M40	PVST	10	3.18	5	M 3.5
	02 10 897	RDPX 1003 M0T	P25	PVGO	10	3.18	5	M 3.5
	02 10 8099	RDMT 1003 M0EN	M35	PCTC	10	3.18	5	M 3.5

Application data (fz / ap)

Material							
Coating grade	Feed rate/ Depth of cut	Steel	Stainless steel	Cast iron	NF metal and non-metals	High-temperature resistant alloys	Hardened materials
K10 PVTi	f _z (mm) a _p (mm)	0.1-0.2 0.1-0.55	0.15 0.1	0.15-0.3 0.1-1	0.1-0.2 0.1-0.8	–	0.1-0.15 0.1-0.3
P40 PCSR	f _z (mm) a _p (mm)	0.2-1 0.2-1.5	–	0.1-0.8 0.1-1.2	–	–	–
P40 PVML	f _z (mm) a _p (mm)	0.2-0.7 0.2-1.5	–	0.1-0.3 0.1-1	–	–	0.1-0.15 0.1-0.3
P40 PVGO	f _z (mm) a _p (mm)	0.1-0.9 0.1-1.5	–	0.1-0.3 0.1-1	–	–	–
P25 PVSR	f _z (mm) a _p (mm)	0.2-0.7 0.2-1.5	–	0.1-0.3 0.1-1	–	–	0.1-0.15 0.1-0.3
CBN for steel uncoated	f _z (mm) a _p (mm)	–	–	–	–	–	0.1-0.2 0.1
CBN for cast iron uncoated	f _z (mm) a _p (mm)	–	–	0.1-0.2 0.1	–	–	–
K10 Polished	f _z (mm) a _p (mm)	–	–	–	0.1-0.3 0.1-1.5	–	–
K10 PVDiaN	f _z (mm) a _p (mm)	–	–	–	0.1-0.3 0.1-1.5	–	–
M40 PVST	f _z (mm) a _p (mm)	0.1-0.75 0.1-1	0.05-0.6 0.2-2	–	–	0.05-0.4 0.1-2	–
P25 PVGO	f _z (mm) a _p (mm)	–	0.15-0.6 0.2-1	–	–	0.1-0.4 0.1-1	–
M35 PCTC	f _z (mm) a _p (mm)	–	0.05-0.6 0.2-2	–	–	0.05-0.4 0.1-2	–

Spindle speed (Vc in m/min)

Material							
Coating grade	Application	Steel	Stainless steel	Cast iron	NF metal and non-metals	High-temperature resistant alloys	Hardened materials
K10 PVTi	Roughing Semi-Finish Finish	–	–	▽100 150 200	–	–	–
		▽150 275 400 ▽150 275 400	– –	▽150 225 300 ▽200 275 350	▽200 500 800 ▽100 450 800	–	▽35 143 250 ▽35 143 250
P40 PCSR	Roughing Semi-Finish Finish	▽130 190 250	–	▽120 170 220	–	–	–
		▽150 225 300 –	–	▽150 200 250 ▽180 230 280	–	–	–
P40 PVML	Roughing Semi-Finish Finish	▽100 200 300	–	▽140 215 290	–	–	–
		▽100 200 300 –	–	▽140 170 200 –	–	–	▽70 110 150 –
P40 PVGO	Roughing Semi-Finish Finish	▽100 150 200	–	▽110 130 150	–	–	–
		▽100 150 200 –	–	▽110 130 150 –	–	–	–
P25 PVSR	Roughing Semi-Finish Finish	▽100 160 220	–	▽140 180 220	–	–	–
		▽100 180 260 –	–	▽160 190 220 ▽160 190 220	–	–	▽70 110 150 –
CBN for steel uncoated	Roughing Semi-Finish Finish	–	–	–	–	–	– – ▽400 700 1000
CBN for cast iron uncoated	Roughing Semi-Finish Finish	–	–	– – ▽400 700 1000	–	–	–
K10 Polished	Roughing Semi-Finish Finish	–	–	–	▽100 450 800 ▽100 450 800 ▽100 450 800	–	–
K10 PVDiaN	Roughing Semi-Finish Finish	–	–	–	▽100 450 800 ▽100 450 800 ▽100 450 800	–	–
M40 PVST	Roughing Semi-Finish Finish	▽80 140 200	▽80 130 180	–	–	▽30 55 80	–
		▽100 150 200 ▽110 180 250	▽100 155 210 ▽120 185 250	–	–	▽40 65 90 ▽60 90 120	–
P25 PVGO	Roughing Semi-Finish Finish	–	▽80 140 200	–	–	▽20 65 110	–
		–	▽100 155 210 ▽120 175 230	–	–	▽20 65 110 ▽30 70 110	–
M35 PCTC	Roughing Semi-Finish Finish	–	▽110 155 200	–	–	▽30 65 100	–
		–	▽120 175 230 ▽160 220 280	–	–	▽40 75 110 ▽60 100 140	–

Expanded application data

Full axial plunge

Arbor Ø d1	X _{max} mm
25-35	2.5
42-52	3.5

Full oblique plunge

Arbor Ø d1	α°	y mm
25	<19.7	7
35	<8.4	17
42	<5.9	24
52	<4.2	34

Circular milling

Arbor Ø d1	D _{min} mm	D _{max} mm
25	32	50
35	52	70
42	66	84
52	86	104

Round insert cutters K0-90°

r5 - Ø 20 - 35 mm, CBN, neutral



Characteristics:



Milling cutter bodies	Part no.	d ₁	d	r	l ₃	l ₂	l ₁	d ₂	d ₃	z
-----------------------	----------	----------------	---	---	----------------	----------------	----------------	----------------	----------------	---

DuoPlug®

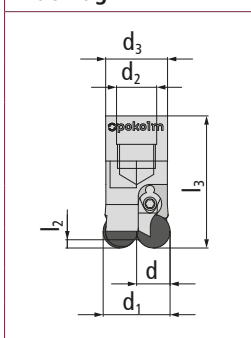

2 20 294 SG	20	10	5	39.5	–	–	M 12	18.5	2
3 25 294 SG	25	10	5	41.5	2.5	–	M 16	23.5	3

Threaded shank end mill body

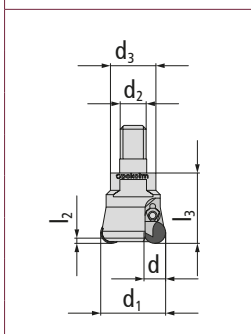

20 294	20	10	5	28.5	–	–	M 10	18	2
25 294	25	10	5	32.5	2.5	–	M 12	21	3
30 294	30	10	5	32.5	2.5	–	M 12	21	4
35 294	35	10	5	42.5	2.5	–	M 16	29	4

The accessories shown here must be used for all sizes!

Accessories

10 500	Torx screw	> Page 197
SG25	TORQUE CliX-S grip	> Page 199
TG55	TORQUE CliX-T grip	> Page 199
DM25	Torque adapter 2.5 Nm	> Page 199
T10-R	6-pack bits (Torx)	> Page 200
10 514	Clamp for CBN	> Page 200

Indexable inserts	Part no.	DIN designation	Quality	Coating	d	s	r	M
-------------------	----------	-----------------	---------	---------	---	---	---	---

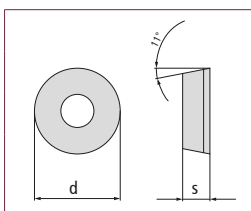

02 10 092	RPHN 1003 M0	CBN for steel	uncoated	10	3.18	5	–
02 10 093	RPHN 1003 M0	CBN for cast iron	uncoated	10	3.18	5	–

Application data (fz / ap)

Material							
Coating grade	Feed rate/ Depth of cut	Steel	Stainless steel	Cast iron	NF metal and non-metals	High-temperature resistant alloys	Hardened materials
CBN for steel uncoated	f _z (mm) a _p (mm)	-	-	-	-	-	0.1-0.2 0.1-0.3
CBN for cast iron uncoated	f _z (mm) a _p (mm)	-	-	0.1-0.2 0.1-0.3	-	-	-

Spindle speed (Vc in m/min)

Material							
Coating grade	Application	Steel	Stainless steel	Cast iron	NF metal and non-metals	High-temperature resistant alloys	Hardened materials
CBN for steel uncoated	Roughing Semi-Finish Finish	-	-	-	-	-	- ▽400 700 1000 ▽400 700 1000
CBN for cast iron uncoated	Roughing Semi-Finish Finish	-	-	- ▽500 750 1000 ▽500 750 1000	-	-	-

Expanded application data

Full axial plunge

Arbor Ø d1	X _{max} mm
20-35	2.5

Full oblique plunge

Arbor Ø d1	α°	y mm
20	-	-
25	<19.7	7
30	<11.7	12
35	<8.4	17

Circular milling

Arbor Ø d1	D _{min} mm	D _{max} mm
20	22	40
25	32	50
30	42	60
35	52	70

Round insert cutters K0-90°

r6 - Ø 42 - 80 mm, 7° positive, shim



Characteristics:



Milling cutter bodies	Part no.	d ₁	d	r	l ₃	l ₂	l ₁	d ₂	d ₃	z
-----------------------	----------	----------------	---	---	----------------	----------------	----------------	----------------	----------------	---

Shell-type milling cutter body

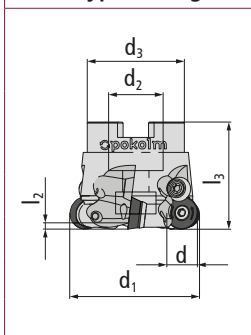

42 310/7 HL	42	12	6	42	3.5	-	16	35	4
52 310/7 HL	52	12	6	52.5	3.5	-	22	40	5
66 310/7 HL	66	12	6	52.5	3.5	-	27	48	6
80 310/7 HL	80	12	6	52.5	3.5	-	27	60	7

The accessories shown here must be used for all sizes!

Accessories

35 500 L	Torx screw	> Page 197
35 510	Clamping screw	> Page 197
35 500 I	Threaded bush	> Page 198
09 511	Shim for RDHX 12T3	> Page 198
15 500	Torx wrench	> Page 198
ALLEN 3.5 W	Allen wrench size 3.5	> Page 199
SG25	TORQUE CliX-S grip	> Page 199
TG55	TORQUE CliX-T grip	> Page 199
DM25	Torque adapter 2.5 Nm	> Page 199
T15-R	6-pack bits (Torx)	> Page 200

ROUND INSERT CUTTERS – COPY END MILLS

Indexable inserts	Part no.	DIN designation	Quality	Coating	d	s	r	M
	03 12 8035K	RDHX 12T3 M0T	HSC 05	PVTi	12	3.97	6	M 3.5
	03 12 837K	RDMX 12T3 M0T	HSC 05	PVFN	12	3.97	6	M 3.5
	03 12 8042K	RDEX 12T3 M0T	P40	PCSR	12	3.97	6	M 3.5
	03 12 846K	RDMX 12T3 M0T	P40	PVGO	12	3.97	6	M 3.5
	03 12 8242K	RDKW 12T3 M0S	P40	PATM	12	3.97	6	M 3.5
	03 12 852K	RDEX 12T3 M0T	P25	PVSR	12	3.97	6	M 3.5
	03 12 831P	RDHX 12T3 M0T	K10	Polished	12	3.97	6	M 3.5
	03 12 848K	RDMX 12T3 M0T	P40	PVGO	12	3.97	6	M 3.5
	03 12 880	RDHX 12T3 M0T	K10	PVTi	12	3.97	6	M 3.5
	03 12 880 D	RDHX 12T3 M0T	K10	PVDiaN	12	3.97	6	M 3.5
	03 12 896K	RDMT 12T3 M0EN	M40	PVST	12	3.97	6	M 3.5
	03 12 897K	RDPX 12T3 M0T	P25	PVGO	12	3.97	6	M 3.5
	03 12 8099K	RDMT 12T3 M0EN	M35	PCTC	12	3.97	6	M 3.5

Application data (fz / ap)

Material							
Coating grade	Feed rate/ Depth of cut	Steel	Stainless steel	Cast iron	NF metal and non-metals	High-temperature resistant alloys	Hardened materials
K10 PVTi	f_z (mm) a_p (mm)	0.1-0.2 0.1-0.8	0.15 0.1	0.15-0.4 0.1-1.5	0.1-0.25 0.1-1.05	–	0.1-0.18 0.1-0.4
HSC 05 PVFN	f_z (mm) a_p (mm)	0.1-0.4 0.1-1.5	0.12-0.24 0.1-0.3	0.12-0.4 0.1-1.5	0.12-0.24 0.1-0.3	–	0.1-0.25 0.1-0.7
P40 PCSR	f_z (mm) a_p (mm)	0.2-1 0.2-2	–	0.15-1 0.2-1.5	–	–	–
P40 PATM	f_z (mm) a_p (mm)	0.2-1 0.2-2	–	0.15-1 0.2-1.5	–	–	–
P40 PVGO	f_z (mm) a_p (mm)	0.12-1 0.1-2	–	0.1-0.4 0.1-1.5	–	–	–
P25 PVSR	f_z (mm) a_p (mm)	0.2-0.8 0.2-2	–	0.1-0.4 0.1-1.5	–	–	0.1-0.18 0.1-0.4
K10 Polished	f_z (mm) a_p (mm)	–	–	–	0.1-0.4 0.1-2	–	–
K10 PVDiaN	f_z (mm) a_p (mm)	–	–	–	0.1-0.4 0.1-2	–	–
M40 PVST	f_z (mm) a_p (mm)	0.1-0.8 0.1-2	0.08-0.8 0.1-2.5	–	–	0.08-0.5 0.12-2.5	–
M35 PCTC	f_z (mm) a_p (mm)	–	0.08-0.65 0.1-2.5	–	–	0.08-0.5 0.12-2.5	–
P25 PVGO	f_z (mm) a_p (mm)	–	0.2-0.8 0.25-2	–	–	0.12-0.5 0.12-1.5	–

Spindle speed (Vc in m/min)

Material							
Coating grade	Application	Steel	Stainless steel	Cast iron	NF metal and non-metals	High-temperature resistant alloys	Hardened materials
K10 PVTi	Roughing Semi-Finish Finish	–	–	▽100 150 200	–	–	–
		▽150 275 400	–	▽150 225 300	▽200 500 800		▽35 143 250
HSC 05 PVFN	Roughing Semi-Finish Finish	–	–	▽100 150 200	–	–	–
		▽120 160 200	–	▽100 150 200	▽200 500 800		▽40 130 220
P40 PCSR	Roughing Semi-Finish Finish	▽130 190 250	–	▽120 170 220	–	–	–
		▽150 225 300	–	▽150 200 250	–		–
P40 PVGO	Roughing Semi-Finish Finish	▽100 150 200	–	▽110 130 150	–	–	–
		▽100 150 200	–	▽110 130 150	–		–
P40 PATM	Roughing Semi-Finish Finish	▽100 130 165	–	▽110 130 150	–	–	–
		▽100 130 165	–	▽110 130 150	–		–
P25 PVSR	Roughing Semi-Finish Finish	▽100 160 220	–	▽140 180 220	–	–	–
		▽100 180 260	–	▽160 190 220	–		▽70 110 150
K10 Polished	Roughing Semi-Finish Finish	–	–	–	▽100 450 800	–	–
		–	–	–	▽100 450 800		–
K10 PVDiaN	Roughing Semi-Finish Finish	–	–	–	▽100 450 800	–	–
		–	–	–	▽100 450 800		–
M40 PVST	Roughing Semi-Finish Finish	▽80 140 200	▽80 130 180	–	–	▽30 55 80	–
		▽100 150 200	▽100 155 210	–	–		▽40 65 90
M35 PCTC	Roughing Semi-Finish Finish	–	▽110 155 200	–	–	▽30 65 100	–
		–	▽120 175 230	–	–		▽40 75 110
P25 PVGO	Roughing Semi-Finish Finish	–	▽80 140 200	–	–	▽20 65 110	–
		–	▽100 155 210	–	–		▽20 65 110
P25 PVGO	Roughing Semi-Finish Finish	–	▽80 140 200	–	–	▽20 65 110	–
		–	▽100 155 210	–	–		▽30 70 110

Expanded application data

Full axial plunge

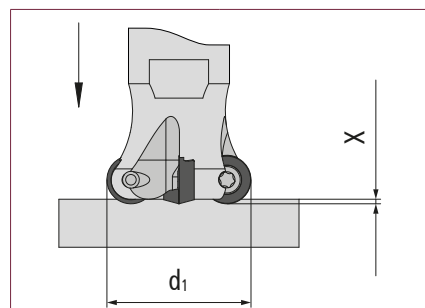

Arbor Ø d1	X _{max} mm
---------------	------------------------

42-80	3
-------	---

Full oblique plunge

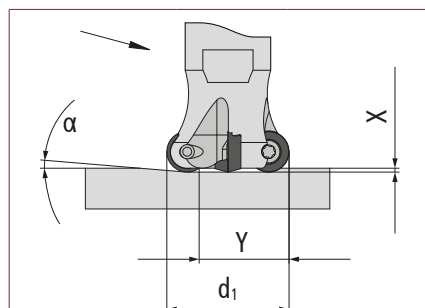

Arbor Ø d1	α°	y mm
---------------	----	---------

42	<6.5	20
52	<5.7	30
66	<3.9	44
80	<3.0	58

Circular milling

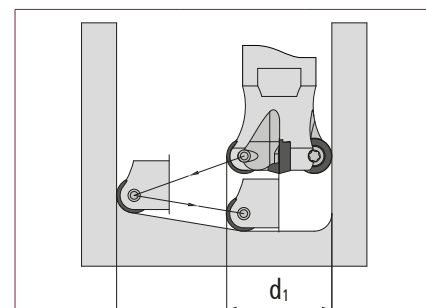

Arbor Ø d1	D _{min} mm	D _{max} mm
---------------	------------------------	------------------------

42	62	84
52	82	104
66	110	132
80	136	160

Round insert cutters K0-90°

r6 - Ø 24 - 80 mm, neutral, 7° positive



Characteristics:



Milling cutter bodies	Part no.	d ₁	d	r	l ₃	l ₂	l ₁	d ₂	d ₃	z
-----------------------	----------	----------------	---	---	----------------	----------------	----------------	----------------	----------------	---

Threaded shank end mill | neutral

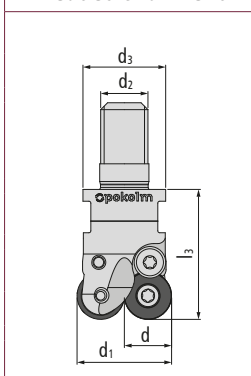

24 200	24	12	6	33	-	-	M 12	21	2		
Accessories	35 510	Clamping screw						> Page 197			
35 200	35	12	6	43	3	-	M 16	29	3		
Accessories	35 510	Clamping screw						> Page 197			
4 35 200	35	12	6	43	3	-	M 16	29	4		
42 200	42	12	6	43	3	-	M 16	29	4		
Accessories	35 510	Clamping screw						> Page 197			
5 42 200	42	12	6	43	3	-	M 16	29	5		

Shell-type milling cutter | neutral

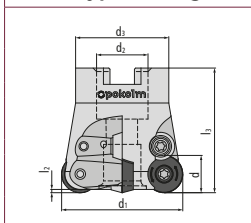

4 42 310	42	12	6	43	3	-	16	35	4		
Accessories	35 510	Clamping screw						> Page 197			
5 42 310	42	12	6	43	3	-	16	35	5		
52 310	52	12	6	53	3.5	-	22	40	5		
Accessories	35 510	Clamping screw						> Page 197			

Threaded shank end mill | 7° positive

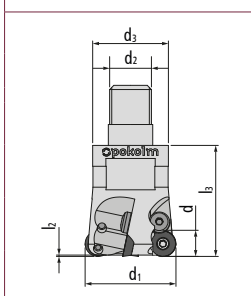

3 35 200/7	35	12	6	42.5	3	-	M 16	29	3		
Accessories	35 510	Clamping screw						> Page 197			
4 35 200/7	35	12	6	42.5	3	-	M 16	29	4		

The accessories shown here must be used for all sizes!

Accessories	15 500	Torx wrench						> Page 198			
--------------------	--------	-------------	--	--	--	--	--	------------	--	--	--

ROUND INSERT CUTTERS – COPY END MILLS

Milling cutter bodies	Part no.	d_1	d	r	l_3	l_2	l_1	d_2	d_3	z	
Shell-type milling cutter 7° positive											
	5 42 310/7	42	12	6	42.6	3.8	–	16	35	5	
	Accessories	35 510	Clamping screw							> Page 197	
		15 500	Torx wrench							> Page 198	
	52 310/7	52	12	6	52.5	3.5	–	22	40	5	
	Accessories	35 510	Clamping screw							> Page 197	
		15 500	Torx wrench							> Page 198	
	66 310/7	66	12	6	52.5	3.5	–	27	48	6	
	Accessories	35 510	Clamping screw							> Page 197	
	80 310/7	80	12	6	52.5	3.5	–	27	60	7	
	Accessories	35 510	Clamping screw							> Page 197	
The accessories shown here must be used for all sizes!	Accessories	35 500	Torx screw							> Page 197	
		SG25	TORQUE CliX-S grip							> Page 199	
		TG55	TORQUE CliX-T grip							> Page 199	
		DM25	Torque adapter 2.5 Nm							> Page 199	
		T15-R	6-pack bits (Torx)							> Page 200	

<2/2

Indexable inserts	Part no.	DIN designation	Quality	Coating	d	s	r	M
	03 12 8035K	RDHX 12T3 M0T	HSC 05	PVTi	12	3.97	6	M 3.5
	03 12 837K	RDMX 12T3 M0T	HSC 05	PVFN	12	3.97	6	M 3.5
	03 12 8042K	RDEX 12T3 M0T	P40	PCSR	12	3.97	6	M 3.5
	03 12 846K	RDMX 12T3 M0T	P40	PVGO	12	3.97	6	M 3.5
	03 12 852K	RDEX 12T3 M0T	P25	PVSR	12	3.97	6	M 3.5
	03 12 8242K	RDKW 12T3 M0S	P40	PATM	12	3.97	6	M 3.5
	03 12 831P	RDHX 12T3 M0T	K10	Polished	12	3.97	6	M 3.5
	03 12 848K	RDMX 12T3 M0T	P40	PVGO	12	3.97	6	M 3.5
	03 12 880	RDHX 12T3 M0T	K10	PVTi	12	3.97	6	M 3.5
	03 12 880 D	RDHX 12T3 M0T	K10	PVDiaN	12	3.97	6	M 3.5
	03 12 896K	RDMT 12T3 M0EN	M40	PVST	12	3.97	6	M 3.5
	03 12 897K	RDPX 12T3 M0T	P25	PVGO	12	3.97	6	M 3.5
	03 12 8099K	RDMT 12T3 M0EN	M35	PCTC	12	3.97	6	M 3.5

Application data (fz / ap)

Material							
Coating grade	Feed rate/ Depth of cut	Steel	Stainless steel	Cast iron	NF metal and non-metals	High-temperature resistant alloys	Hardened materials
HSC PVTi	f _z (mm) a _p (mm)	0.1-0.2 0.1-0.8	0.15 0.1	0.15-0.4 0.1-1.5	0.1-0.25 0.1-1.05	–	0.1-0.18 0.1-0.4
HSC 05 PVFN	f _z (mm) a _p (mm)	0.1-0.4 0.1-1.5	0.12-0.24 0.1-0.3	0.12-0.4 0.1-1.5	0.12-0.24 0.1-0.3	–	0.1-0.25 0.1-0.7
P40 PCSR	f _z (mm) a _p (mm)	0.2-1 0.2-2	–	0.15-1 0.2-1.5	–	–	–
P40 PCSR	f _z (mm) a _p (mm)	0.2-1 0.2-2	–	0.15-1 0.2-1.5	–	–	–
P40 PATM	f _z (mm) a _p (mm)	0.12-1 0.1-2	–	0.1-0.4 0.1-1.5	–	–	–
P25 PVSR	f _z (mm) a _p (mm)	0.2-0.8 0.2-2	–	0.1-0.4 0.1-1.5	–	–	0.1-0.18 0.1-0.4
K10 Polished	f _z (mm) a _p (mm)	–	–	–	0.1-0.4 0.1-2	–	–
K10 PVDiaN	f _z (mm) a _p (mm)	–	–	–	0.1-0.4 0.1-2	–	–
M40 PVST	f _z (mm) a _p (mm)	0.1-0.8 0.1-2	0.08-0.8 0.1-2.5	–	–	0.08-0.5 0.12-2.5	–
M35 PCTC	f _z (mm) a _p (mm)	–	0.08-0.65 0.1-2.5	–	–	0.08-0.5 0.12-2.5	–
P25 PVGO	f _z (mm) a _p (mm)	–	0.2-0.8 0.25-2	–	–	0.12-0.5 0.12-1.5	–

Spindle speed (Vc in m/min)

Material							
Coating grade	Application	Steel	Stainless steel	Cast iron	NF metal and non-metals	High-temperature resistant alloys	Hardened materials
HSC PVTi	Roughing Semi-Finish Finish	–	–	▼100 150 200	–	–	–
		▼150 275 400	–	▼150 225 300	▼200 500 800	–	▼35 143 250
		▼150 275 400	▼100 150 200	▼200 275 350	▼100 450 800	–	▼35 143 250
HSC 05 PVFN	Roughing Semi-Finish Finish	–	–	▼100 150 200	–	–	–
		▼120 160 200	–	▼100 150 200	▼200 500 800	–	▼40 130 220
		▼150 250 350	▼100 150 200	▼200 275 350	▼200 500 800	–	▼40 130 220
P40 PCSR	Roughing Semi-Finish Finish	▼130 190 250	–	▽120 170 220	–	–	–
		▼150 225 300	–	▽150 200 250	–	–	–
		–	–	▽180 230 280	–	–	–
P40 PATM	Roughing Semi-Finish Finish	▼130 190 250	–	▽120 170 220	–	–	–
		▼150 225 300	–	▽150 200 250	–	–	–
		–	–	▽180 230 280	–	–	–
P40 PVGO	Roughing Semi-Finish Finish	▼100 150 200	–	▽110 130 150	–	–	–
		▼100 150 200	–	▽110 130 150	–	–	–
		–	–	–	–	–	–
P25 PVSR	Roughing Semi-Finish Finish	▼100 160 220	–	▽140 180 220	–	–	–
		▼100 180 260	–	▽160 190 220	–	–	▽70 110 150
		–	–	▽160 190 220	–	–	–
K10 Polished	Roughing Semi-Finish Finish	–	–	–	▼100 450 800	–	–
		–	–	–	▼100 450 800	–	–
		–	–	–	▼100 450 800	–	–
K10 PVDiaN	Roughing Semi-Finish Finish	–	–	–	▼100 450 800	–	–
		–	–	–	▼100 450 800	–	–
		–	–	–	▼100 450 800	–	–
M40 PVST	Roughing Semi-Finish Finish	▽80 140 200	▼80 130 180	–	–	▼30 55 80	–
		▼100 150 200	▼100 155 210	–	–	▼40 65 90	–
		▼110 180 250	▼120 185 250	–	–	▼60 90 120	–
M35 PCTC	Roughing Semi-Finish Finish	–	▼110 155 200	–	–	▼30 65 100	–
		–	▼120 175 230	–	–	▼40 75 110	–
		–	▼160 220 280	–	–	▼60 100 140	–
P25 PVGO	Roughing Semi-Finish Finish	–	▼80 140 200	–	–	▼20 65 110	–
		–	▼100 155 210	–	–	▼20 65 110	–
		–	▼120 175 230	–	–	▼30 70 110	–

Expanded application data

Full axial plunge

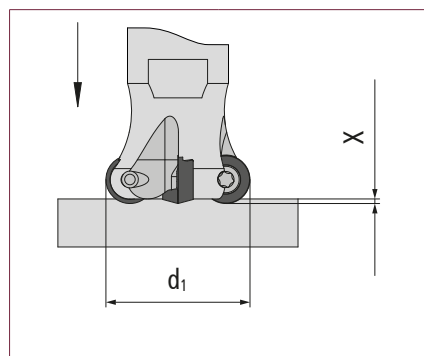

Arbor Ø d1	X _{max} mm
---------------	------------------------

24-80	3
-------	---

Full oblique plunge

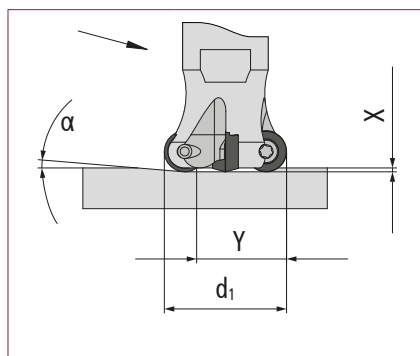

Arbor Ø d1	α°	y mm
---------------	----	---------

24	-	-
35	<13.0	13
42	<6.5	20
52	<5.7	30
66	<3.9	44
80	<3.0	58

Circular milling

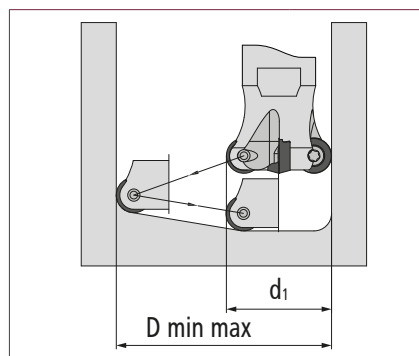

Arbor Ø d1	D _{min} mm	D _{max} mm
---------------	------------------------	------------------------

24	26	48
35	46	70
42	62	84
52	82	104
66	110	132
80	136	160

Round insert cutters K0-90°

r8 - Ø 52 - 100 mm, 7° positive, shim

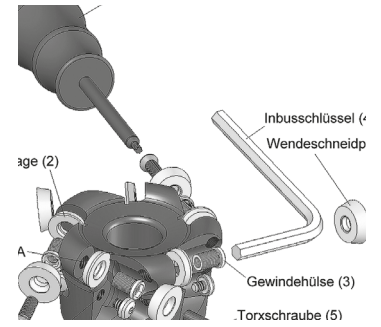
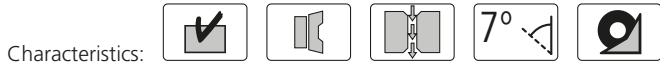

Milling cutter bodies	Part no.	d ₁	d	r	l ₃	l ₂	l ₁	d ₂	d ₃	z
-----------------------	----------	----------------	---	---	----------------	----------------	----------------	----------------	----------------	---

Shell-type milling cutter body										
	52 300/7 HL	52	16	8	53	4.1	–	22	40	4
	66 300/7 HL	66	16	8	53	4.1	–	27	48	5
	80 300/7 HL	80	16	8	53	4.1	–	27	60	6
	100 300/7 HL	100	16	8	53	4.1	–	32	70	7

<p>The accessories shown here must be used for all sizes!</p>	<p>Accessories</p>	45 500	Torx screw	> Page 197
		45 500 L	Torx screw	> Page 197
		45 500 I	Threaded bush	> Page 198
		10 510	Locking washer	> Page 197
		10 511	Shim for RDHX 1604	> Page 198
		20 500	Torx wrench	> Page 198
		ALLEN 4.5 W	Allen wrench size 4.5	> Page 199
		SG25	TORQUE CliX-S grip	> Page 199
		TG55	TORQUE CliX-T grip	> Page 199
		DM55	Torque adapter 5.5 Nm	> Page 199
T20-R	6-pack bits (Torx)	> Page 200		

Indexable inserts	Part no.	DIN designation	Quality	Coating	d	s	r	M
	04 16 8035	RDHX 1604 M0T	HSC 05	PVTi	16	4.76	8	M 4.5
	04 16 8042	RDEX 1604 M0T	P40	PCSR	16	4.76	8	M 4.5
	04 16 844	RDHX 1604 M0T	P40	PVML	16	4.76	8	M 4.5
	04 16 852	RDEX 1604 M0T	P25	PVSR	16	4.76	8	M 4.5
	04 16 8242	RDKW 1604 M0S	P40	PATM	16	4.76	8	M 4.5
	04 16 831P	RDHX 1604 M0T	K10	Polished	16	4.76	8	M 4.5
	04 16 848	RDMX 1604 M0T	P40	PVGO	16	4.76	8	M 4.5
	04 16 880	RDHX 1604 M0T	K10	PVTi	16	4.76	8	M 4.5
	04 16 896	RDMT 1604 M0EN	M40	PVST	16	4.76	8	M 4.5
	04 16 8099	RDMT 1604 M0EN	M35	PCTC	16	4.76	8	M 4.5
	04 16 897	RDPX 1604 M0T	P25	PVGO	16	4.76	8	M 4.5

Application data (fz / ap)

Material							
Coating grade	Feed rate/ Depth of cut	Steel	Stainless steel	Cast iron	NF metal and non-metals	High-temperature resistant alloys	Hardened materials
HSC PVTi	f _z (mm) a _p (mm)	0.2-0.25 0.2-0.85	0.15 0.1	0.2-0.5 0.2-3	0.2-0.35 0.2-2.1	–	0.15-0.22 0.2-0.85
P40 PCSR	f _z (mm) a _p (mm)	0.25-1 0.25-3	–	0.25-1 0.25-3	–	–	–
P40 PATM	f _z (mm) a _p (mm)	0.25-1 0.25-3	–	0.25-1 0.25-3	–	–	–
P40 PVML	f _z (mm) a _p (mm)	0.25-1 0.2-3	–	0.2-0.5 0.2-3	–	–	0.15-0.22 0.2-0.85
P25 PVSR	f _z (mm) a _p (mm)	0.25-1 0.2-3	–	0.2-0.5 0.2-3	–	–	0.15-0.22 0.2-0.85
K10 Polished	f _z (mm) a _p (mm)	–	–	–	0.2-0.5 0.2-4	–	–
P40 PVGO	f _z (mm) a _p (mm)	0.16-1.2 0.1-3	–	0.16-0.5 0.1-2	–	–	–
M40 PVST	f _z (mm) a _p (mm)	0.08-1.2 0.1-3	0.08-0.7 0.1-3	–	–	0.08-0.5 0.1-2	–
M35 PCTC	f _z (mm) a _p (mm)	–	0.08-0.7 0.1-3	–	–	0.08-0.5 0.12-3	–
P25 PVGO	f _z (mm) a _p (mm)	–	0.3-1 0.3-3	–	–	0.15-0.5 0.15-2	–

Spindle speed (Vc in m/min)

Material							
Coating grade	Application	Steel	Stainless steel	Cast iron	NF metal and non-metals	High-temperature resistant alloys	Hardened materials
HSC PVTi	Roughing Semi-Finish Finish	– ▽150 275 400 ▽150 275 400	– – ▽100 150 200	▽100 150 200 ▽150 225 300 ▽200 275 350	– ▽200 500 800 ▽100 450 800	–	– ▽35 143 250 ▽35 143 250
P40 PCSR	Roughing Semi-Finish Finish	▽130 190 250 ▽150 225 300 –	–	▽120 170 220 ▽150 200 250 ▽180 230 280	–	–	–
P40 PATM	Roughing Semi-Finish Finish	▽130 190 250 ▽150 225 300 –	–	▽120 170 220 ▽150 200 250 ▽180 230 280	–	–	–
P40 PVML	Roughing Semi-Finish Finish	▽100 200 300 ▽100 200 300 –	–	▽140 215 290 ▽140 170 200 –	–	–	– ▽70 110 150 –
P25 PVSR	Roughing Semi-Finish Finish	▽100 160 220 ▽100 180 260 –	–	▽140 180 220 ▽160 190 220 ▽160 190 220	–	–	– ▽70 110 150 –
K10 Polished	Roughing Semi-Finish Finish	–	–	–	▽100 450 800 ▽100 450 800 ▽100 450 800	–	–
P40 PVGO	Roughing Semi-Finish Finish	▽100 150 200 ▽100 150 200 –	–	▽110 130 150 ▽110 130 150 –	–	–	–
M40 PVST	Roughing Semi-Finish Finish	▽80 140 200 ▽100 150 200 ▽110 180 250	▽80 130 180 ▽100 155 210 ▽120 185 250	–	–	▽30 55 80 ▽40 65 90 ▽60 90 120	–
M35 PCTC	Roughing Semi-Finish Finish	–	▽110 155 200 ▽120 175 230 ▽160 220 280	–	–	▽30 65 100 ▽40 75 110 ▽60 100 140	–
P25 PVGO	Roughing Semi-Finish Finish	–	▽80 140 200 ▽100 155 210 ▽120 175 230	–	–	▽20 65 110 ▽20 65 110 ▽30 70 110	–

Expanded application data

Full axial plunge

Arbor Ø d1	X _{max} mm
52-100	4

Full oblique plunge

Arbor Ø d1	α°	y mm
52	<10.3	22
66	<6.4	36
80	<4.6	50
100	<3.3	70

Circular milling

Arbor Ø d1	D _{min} mm	D _{max} mm
52	62	104
66	82	132
80	110	160
100	136	200

Round insert cutters K0-90°

r8 - Ø 32 - 160 mm, neutral, 7° positive



Characteristics:



Milling cutter bodies	Part no.	d ₁	l/d	r	l ₃	l ₂	l ₁	d ₂	d ₃	z
-----------------------	----------	----------------	-----	---	----------------	----------------	----------------	----------------	----------------	---

Threaded shank end mill body

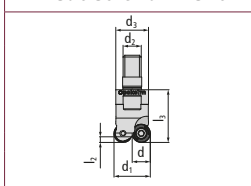

32 200	32	16	8	43.5	–	–	–	M 16	29	2
35 201	35	16	8	43.5	4	–	–	M 16	29	3

Shell-type milling cutter | neutral

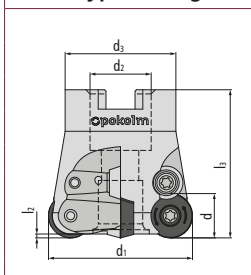

52 300	52	16	8	53.5	4.7	–	–	22	40	4	
66 300	66	16	8	53.5	5.1	–	–	27	48	5	
80 300	80	16	8	53.5	5.8	–	–	27	60	6	
100 300	100	16	8	53.5	5.8	–	–	32	70	7	
Accessories	10 510	Locking washer					> Page 198				

Shell-type milling cutter | 7° positive

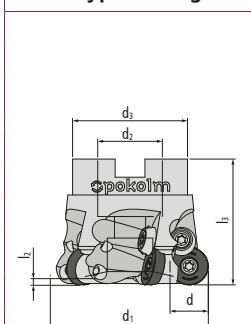

5 52 300/7	52	16	8	53	4.1	–	–	22	40	5	
5 52 300/7 VD	52	16	8	53	4.1	–	–	22	40	5	
66 300/7	66	16	8	53	4.6	–	–	27	48	5	
66 300/7 VD	66	16	8	53	4.6	–	–	27	48	5	
Accessories	10 510	Locking washer					> Page 198				
6 66 300/7	66	16	8	53	5.1	–	–	27	48	6	
80 300/7	80	16	8	53	5.1	–	–	27	60	6	
80 300/7 VD	80	16	8	53	5.1	–	–	27	60	6	
100 300/7*	100	16	8	53	5.1	–	–	32	70	7	
125 300/7*	125	16	8	53	5.1	–	–	40	90	8	
160 300/7*	160	16	8	53	5.1	–	–	40	120	9	
Accessories	10 510	Locking washer					> Page 198				

The accessories shown here must be used for all sizes!

Accessories

20 500	Torx wrench	> Page 198
45 500	Torx screw	> Page 197
SG25	TORQUE CliX-S grip	> Page 199
TG55	TORQUE CliX-T grip	> Page 199
DM55	Torque adapter 5.5 Nm	> Page 199
T20-R	6-pack bits (Torx)	> Page 200

* has no IC

ROUND INSERT CUTTERS – COPY END MILLS

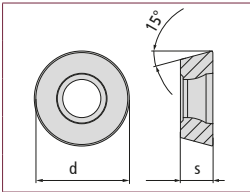
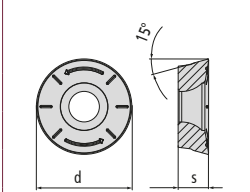
Indexable inserts	Part no.	DIN designation	Quality	Coating	d	s	r	M
	04 16 8035	RDHX 1604 M0T	HSC 05	PVTi	16	4.76	8	M 4.5
	04 16 8042	RDEX 1604 M0T	P40	PCSR	16	4.76	8	M 4.5
	04 16 844	RDHX 1604 M0T	P40	PVML	16	4.76	8	M 4.5
	04 16 852	RDEX 1604 M0T	P25	PVSR	16	4.76	8	M 4.5
	04 16 8242	RDKW 1604 M0S	P40	PATM	16	4.76	8	M 4.5
	04 16 831P	RDHX 1604 M0T	K10	Polished	16	4.76	8	M 4.5
	04 16 848	RDMX 1604 M0T	P40	PVGO	16	4.76	8	M 4.5
	04 16 880	RDHX 1604 M0T	K10	PVTi	16	4.76	8	M 4.5
	04 16 896	RDMT 1604 M0EN	M40	PVST	16	4.76	8	M 4.5
	04 16 8099	RDMT 1604 M0EN	M35	PCTC	16	4.76	8	M 4.5
	04 16 897	RDPX 1604 M0T	P25	PVGO	16	4.76	8	M 4.5

Application data (fz / ap)

Material							
Coating grade	Feed rate/ Depth of cut	Steel	Stainless steel	Cast iron	NF metal and non-metals	High-temperature resistant alloys	Hardened materials
HSC PVTi	f _z (mm) a _p (mm)	0.2-0.25 0.2-0.85	0.15 0.1	0.2-0.5 0.2-3	0.2-0.35 0.2-2.1	–	0.15-0.22 0.2-0.85
P40 PCSR	f _z (mm) a _p (mm)	0.25-1 0.25-3	–	0.25-1 0.25-3	–	–	–
P40 PATM	f _z (mm) a _p (mm)	0.25-1 0.25-3	–	0.25-1 0.25-3	–	–	–
P40 PVML	f _z (mm) a _p (mm)	0.25-1 0.2-3	–	0.2-0.5 0.2-3	–	–	0.15-0.22 0.2-0.85
P25 PVSR	f _z (mm) a _p (mm)	0.25-1 0.2-3	–	0.2-0.5 0.2-3	–	–	0.15-0.22 0.2-0.85
K10 Polished	f _z (mm) a _p (mm)	–	–	–	0.2-0.5 0.2-4	–	–
P40 PVGO	f _z (mm) a _p (mm)	0.16-1.2 0.1-3	–	0.16-0.5 0.1-2	–	–	–
M40 PVST	f _z (mm) a _p (mm)	0.08-1.2 0.1-3	0.08-0.7 0.1-3	–	–	0.08-0.5 0.1-2	–
M35 PCTC	f _z (mm) a _p (mm)	–	0.08-0.7 0.1-3	–	–	0.08-0.5 0.12-3	–
P25 PVGO	f _z (mm) a _p (mm)	–	0.3-1 0.3-3	–	–	0.15-0.5 0.15-2	–

Spindle speed (Vc in m/min)

Material							
Coating grade	Application	Steel	Stainless steel	Cast iron	NF metal and non-metals	High-temperature resistant alloys	Hardened materials
HSC PVTi	Roughing Semi-Finish Finish	–	–	▽100 150 200	–	–	–
		▽150 275 400 ▽150 275 400	– –	▽150 225 300 ▽200 275 350	▽200 500 800 ▽100 450 800	–	▽35 143 250 ▽35 143 250
P40 PCSR	Roughing Semi-Finish Finish	▽130 190 250	–	▽120 170 220	–	–	–
		▽150 225 300 –	–	▽150 200 250 ▽180 230 280	–	–	–
P40 PATM	Roughing Semi-Finish Finish	▽130 190 250	–	▽120 170 220	–	–	–
		▽150 225 300 –	–	▽150 200 250 ▽180 230 280	–	–	–
P40 PVML	Roughing Semi-Finish Finish	▽100 200 300	–	▽140 215 290	–	–	–
		▽100 200 300 –	–	▽140 170 200 –	–	–	▽70 110 150 –
P25 PVSR	Roughing Semi-Finish Finish	▽100 160 220	–	▽140 180 220	–	–	–
		▽100 180 260 –	–	▽160 190 220 ▽160 190 220	–	–	▽70 110 150 –
K10 Polished	Roughing Semi-Finish Finish	–	–	–	▽100 450 800	–	–
		–	–	–	▽100 450 800 ▽100 450 800	–	–
P40 PVGO	Roughing Semi-Finish Finish	▽100 150 200	–	▽110 130 150	–	–	–
		▽100 150 200 –	–	▽110 130 150 –	–	–	–
M40 PVST	Roughing Semi-Finish Finish	▽80 140 200	▽80 130 180	–	–	▽30 55 80	–
		▽100 150 200	▽100 155 210	–	–	▽40 65 90	–
		▽110 180 250	▽120 185 250	–	–	▽60 90 120	–
M35 PCTC	Roughing Semi-Finish Finish	–	▽110 155 200	–	–	▽30 65 100	–
		–	▽120 175 230	–	–	▽40 75 110	–
		–	▽160 220 280	–	–	▽60 100 140	–
P25 PVGO	Roughing Semi-Finish Finish	–	▽80 140 200	–	–	▽20 65 110	–
		–	▽100 155 210	–	–	▽20 65 110	–
		–	▽120 175 230	–	–	▽30 70 110	–

Expanded application data

Full axial plunge

Arbor Ø d1	X _{max} mm
32-160	4

Full oblique plunge

Arbor Ø d1	α°	y mm
32	–	–
35	<38.7	5
52	<10.3	22
66	<6.4	36
80	<4.6	50
100	<3.3	70
125	<2.4	95
160	<1.5	130

Circular milling

Arbor Ø d1	D _{min} mm	D _{max} mm
32	34	64
35	40	70
52	74	104
66	102	132
80	130	160
100	170	200
125	220	250
160	290	320

Round insert cutters K0-90°

r10 - Ø 40 - 160 mm, neutral, 7° positive



Characteristics:



Milling cutter bodies	Part no.	d_1	d	r	l_3	l_2	l_1	d_2	d_3	z
-----------------------	----------	-------	-----	-----	-------	-------	-------	-------	-------	-----

Threaded shank end mill body

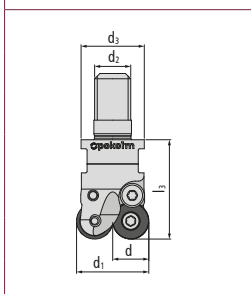

40 200	40	20	10	53.5	-	-	M 16	29	2
--------	----	----	----	------	---	---	------	----	---

Shell-type milling cutter | 7° positive

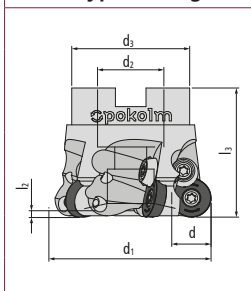

5 66 340/7	66	20	10	53	6.5	-	27	48	5
80 340/7	80	20	10	53	6.5	-	27	60	5
100 340/7	100	20	10	53	6.5	-	32	70	6
125 340/7	125	20	10	53	6.5	-	40	90	7
160 340/7	160	20	10	53	6.5	-	40	120	8

The accessories shown here must be used for all sizes!

Accessories

45 500	Torx screw	> Page 197
10 510	Locking washer	> Page 197
20 500	Torx wrench	> Page 198
SG25	TORQUE CliX-S grip	> Page 199
TG55	TORQUE CliX-T grip	> Page 199
DM55	Torque adapter 5.5 Nm	> Page 199

ROUND INSERT CUTTERS – COPY END MILLS

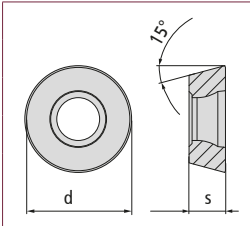
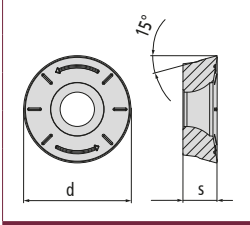
Indexable inserts	Part no.	DIN designation	Quality	Coating	d	s	r	M
	06 20 835	RDMX 2006 M0T	HSC 05	PVTi	20	6	10	M 4.5
	06 20 840	RDMX 2006 M0T	P40	PVTi	20	6	10	M 4.5
	06 20 850	RDMX 2006 M0T	P25	PVTi	20	6	10	M 4.5
	06 20 860	RDMX 2006 M0T	K10	PVTi	20	6	10	M 4.5
	06 20 831P	RDHT 2006 M0T	K10	Polished	20	6	10	M 4.5
	06 20 880	RDHT 2006 M0T	K10	PVTi	20	6	10	M 4.5

Application data (fz / ap)

Material							
Coating grade	Feed rate/ Depth of cut	Steel	Stainless steel	Cast iron	NF metal and non-metals	High-temperature resistant alloys	Hardened materials
HSC 05 PVTi	f _z (mm) a _p (mm)	0.25-0.32 0.2-1.1	0.15 0.1	0.25-0.6 0.2-4	0.25-0.42 0.2-5	–	0.2-0.3 0.2-1.1
P40 PVTi	f _z (mm) a _p (mm)	0.25-1.2 0.2-5	–	–	–	–	–
P25 PVTi	f _z (mm) a _p (mm)	0.25-0.6 0.2-4	–	0.25-0.42 0.2-2.1	–	–	–
K10 PVTi	f _z (mm) a _p (mm)	–	0.15 0.1	–	0.25-0.6 0.2-5	0.2-0.4 0.2-3	–
K10 Polished	f _z (mm) a _p (mm)	–	–	–	0.25-0.6 0.2-5	–	–

Spindle speed (Vc in m/min)

Material							
Coating grade	Application	Steel	Stainless steel	Cast iron	NF metal and non-metals	High-temperature resistant alloys	Hardened materials
HSC 05 PVTi	Roughing	–	–	▽100 150 200	–	–	–
	Semi-Finish Finish	▽150 275 400 ▽150 275 400	– ▽100 150 200	▽150 225 300 ▽200 275 350	▽200 500 800 ▽100 450 800	–	▽35 143 250 ▽35 143 250
P40 PVTi	Roughing	▽100 160 220	–	–	–	–	–
	Semi-Finish Finish	▽100 175 250 –	–	–	–	–	–
P25 PVTi	Roughing	▽100 200 300	–	–	–	–	–
	Semi-Finish Finish	▽100 125 150 ▽150 250 350	–	▽130 150 170 ▽150 200 250	–	–	–
K10 PVTi	Roughing	–	–	▽150 175 200	▽100 450 800	▽35 43 50	–
	Semi-Finish Finish	– ▽140 220 300	– ▽120 150 180	▽150 175 200 ▽150 200 250	▽100 450 800 ▽100 450 800	▽35 43 50 ▽35 43 50	▽35 108 180 –
K10 Polished	Roughing	–	–	–	▽100 450 800	–	–
	Semi-Finish Finish	–	–	–	▽100 450 800 ▽100 450 800	–	–

Expanded application data

Full axial plunge

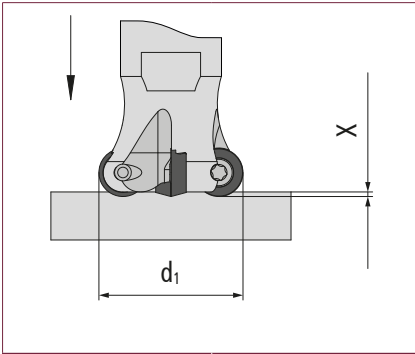

Arbor Ø d1	X _{max} mm
40-160	5

Full oblique plunge

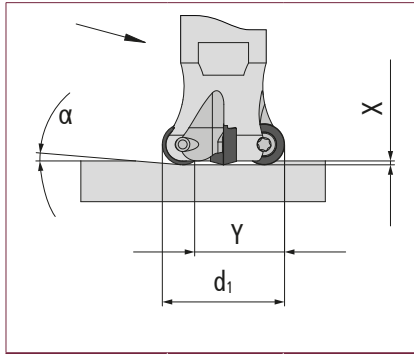

Arbor Ø d1	α°	y mm
40	-	-
66	<10.1	28
80	<6.8	42
100	<4.6	62
125	<3.3	87
160	<2.3	122

Circular milling

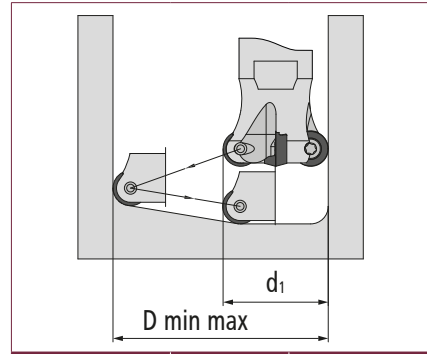

Arbor Ø d1	D _{min} mm	D _{max} mm
40	42	80
66	94	132
80	122	160
100	162	200
125	212	250
160	282	320

THINKING IN SOLUTIONS



Rhombus milling cutters

FINWORX[®] rhombus milling cutters

Economic miracle with 4 cutting flutes

Properties

- Finishing tool for a broad range of applications
- For use in steel, hardened steel, cast iron, and RSH
- CBN & PKD cutting materials for modern substances
- Contour and copy milling
- Circular and inclined plunge



Sizes	Page
Ø 16 - 42 mm	124

Machining types

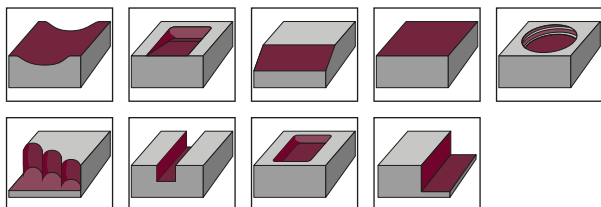

Connection types

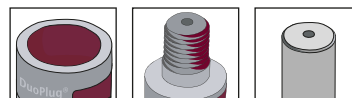

Cutting materials

Coating grade	ISO application						Application data (mm)		Cutting flute length	Thickness	Radius
	P	M	K	N	S	H	f _z	a _p	l (mm)	s (mm)	r (mm)
HSC 05 PVTi	▼	▼	▼	-	-	▼	0.1 - 0.3	0.1 - 1.0	6.5	3	1
HSC 05 PVTiH	▼	▼	▼	-	-	▼	0.05 - 0.55	0.05 - 0.55	6.5	3	1
HSC 05 PVDiaN	-	-	-	▼	-	-	0.05 - 0.3	0.1 - 1.0	6.5	3	1
CBN for steel	-	-	-	-	-	▼	0.05 - 0.1	0.1 - 0.2	6.5	3	1
PKD	-	-	-	▼	-	-	0.05 - 0.2	0.1 - 0.5	6.5	3	1

FINWORX®

Ø 16 - 42 mm | r1



Characteristics:



Milling Cutter Bodies	Part no.	d ₁	l	r	l ₃	l ₂	l ₁	d ₂	d ₃	z
-----------------------	----------	----------------	---	---	----------------	----------------	----------------	----------------	----------------	---

DuoPlug®

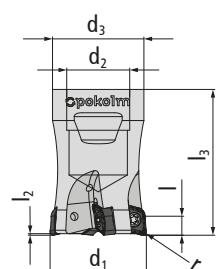

2 16 285 SG	16	6.5	1	31	0.7	–	M 10	15	2
3 20 285 SG	20	6.5	1	32.5	1	–	M 12	18.6	3
4 25 285 SG	25	6.5	1	37.5	1	–	M 16	23.5	4

Threaded shank end mill body

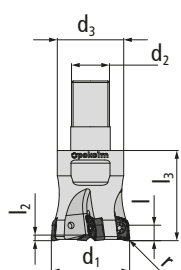

2 16 285	16	6.5	1	28.5	0.7	–	M 8	13.8	2
3 20 285	20	6.5	1	28.5	1	–	M 10	18	3
4 25 285	25	6.5	1	32.5	1	–	M 12	21	4
4 30 285	30	6.5	1	32.5	1	–	M 16	29	4
5 32 285	32	6.5	1	32.5	1	–	M 16	29	5
5 35 285	35	6.5	1	42.5	1	–	M 16	29	5
6 42 285	42	6.5	1	42.5	1	–	M 16	29	6

End mills

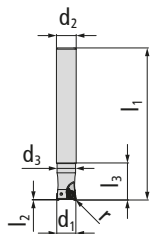

2 32 16 185 G	16	6.5	1	32	0.7	165	16	15.5	2
3 40 20 185 G	20	6.5	1	40	1	165	20	19.5	3

The accessories shown here must be used for all sizes!

Accessories

25 505	Torx screw	> Page 197
08 500 P	Torx wrench (Torx Plus)	> Page 198
SG25	TORQUE CliX-S grip	> Page 199
TG55	TORQUE CliX-T grip	> Page 199
DM10	Torque adapter 1.0 Nm	> Page 199
TP08-R	6-pack bits (Torx Plus)	> Page 200

Indexable Inserts	Part no.	DIN designation	Quality	Coating	l	s	r	M
	03 85 835	XNHU 063010 EN	HSC 05	PVTi	6.5	3.1	1	–
	03 85 836	XNHU 063010 EN	HSC 05	PVTiH	6.5	3.1	1	–
	03 85 835 D	XNHU 063010 EN	HSC 05	PVDiaN	6.5	3.1	1	–
	03 85 892	XNHU 063010 EN	CBN for steel	uncoated	6.5	3.1	1	–
	03 85 894	XNHU 063010 EN	PKD	uncoated	6.5	3.1	1	–

Application data (fz / ap)

Material							
Coating grade	Feed rate/ Depth of cut	Steel	Stainless steel	Cast iron	NF metal and non-metals	High-temperature resistant alloys	Hardened materials
HSC 05 PVTi	f _z (mm) a _p (mm)	0.05-0.5 0.1-0.55	0.05-0.15 0.05-0.2	0.05-0.5 0.1-0.55	–	–	0.05-0.2 0.1-0.35
HSC 05 PVTiH	f _z (mm) a _p (mm)	0.05-0.5 0.1-0.55	0.05-0.15 0.05-0.2	0.05-0.5 0.1-0.55	–	–	0.05-0.2 0.1-0.35
HSC 05 PVDiaN	f _z (mm) a _p (mm)	–	–	–	0.05-0.3 0.1-0.7	–	–
CBN for steel uncoated	f _z (mm) a _p (mm)	–	–	–	–	–	0.05-0.1 0.1
PKD uncoated	f _z (mm) a _p (mm)	–	–	–	0.05-0.2 0.1-0.5	–	–

Spindle speed (Vc in m/min)

Material							
Coating grade	Application	Steel	Stainless steel	Cast iron	NF metal and non-metals	High-temperature resistant alloys	Hardened materials
HSC 05 PVTi	Roughing Semi-Finish Finish	– ▽150 275 400 ▽150 275 400	– – ▽100 150 200	– ▽150 225 300 ▽200 275 350	–	–	– ▽35 143 250 ▽35 143 250
HSC 05 PVTiH	Roughing Semi-Finish Finish	– ▽150 275 400 ▽150 275 400	– – ▽100 150 200	– ▽150 225 300 ▽200 275 350	–	–	– ▽35 143 250 ▽35 143 250
HSC 05 PVDiaN	Roughing Semi-Finish Finish	–	–	–	– ▽200 500 800 ▽200 500 800	–	–
CBN for steel uncoated	Roughing Semi-Finish Finish	–	–	–	–	–	– – ▽400 700 1000
PKD uncoated	Roughing Semi-Finish Finish	–	–	–	– ▽400 600 800 ▽400 700 1000	–	–

Expanded application data

Full axial plunge

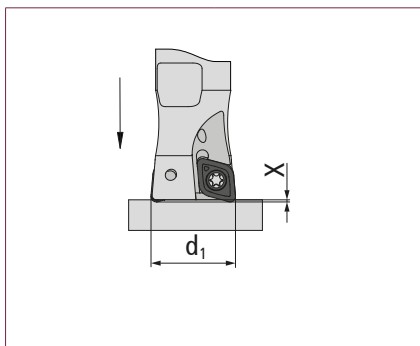

Arbor Ø d1	X _{max} mm
------------	---------------------

16	0.7
20-42	1

Full oblique plunge

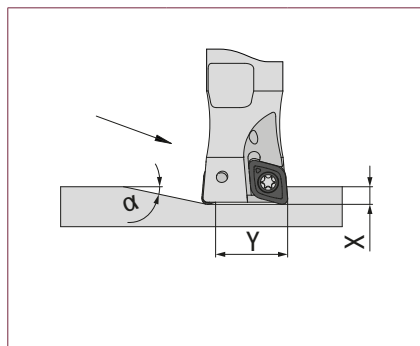

Arbor Ø d1	α°	y mm
------------	----	------

16	<2.8	14
20	<3.2	18
25	<2.5	23
30	<2	28
32	<1.9	30
35	<1.7	33
42	<1.4	40

Circular milling

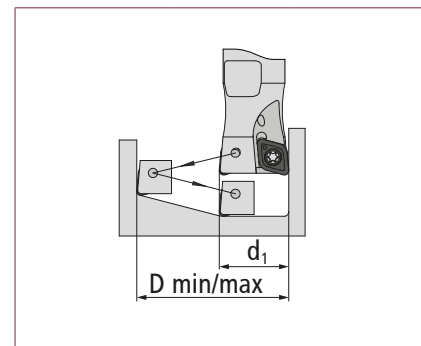

Arbor Ø d1	D _{min} mm	D _{max} mm
------------	---------------------	---------------------

16	30	32
20	38	40
25	48	50
30	58	60
32	62	64
35	68	70
42	82	84

XDHW | XDHT rhombus milling cutter – size 06 / 10

Universal tool for finishing and contour milling with small radii



Properties

- especially smooth tool running in corners and pockets
- low power consumption
- adjustment angle kappa size 06: 93°, size 10: 95

Sizes	Page
06 - Ø 16 - 42 mm r1	128
06 - Ø 16 - 35 mm r2	131
10 - Ø 25 - 80 mm r1	133

Machining types

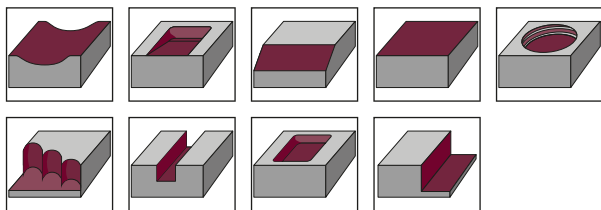

Connection types

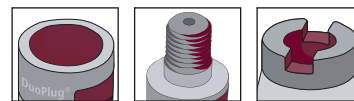





Cutting materials

Coating grade	ISO application						Application data (mm)		Cutting flute length	Thickness	Radius
	P	M	K	N	S	H	f _z	a _p	l (mm)	s (mm)	r (mm)
HSC 05 PVTi	▽	▽	▽	-	-	▽	0.1 - 0.35	0.1 - 1.0	6.5	2.38	1 / 2
							0.1 - 0.4	0.1 - 1.5	10	3.97	1
CBN for steel	-	-	-	-	-	▽	0.1	0.1	6.5	2.38	1
PKD	-	-	-	▽	-	-	0.1 - 0.35	0.1 - 0.1	6.5	2.38	1
K10 polished	-	-	-	▽	-	-	0.1 - 0.35	0.1 - 1.0	6.5	2.38	1
K10 PVTi	-	-	-	▽	-	-	0.1 - 0.35	0.1 - 1.0	6.5	2.38	1
K10 PVDiaN	-	-	-	▽	-	-	0.1 - 0.35	0.1 - 1.0	6.5	2.38	1

XDHW | XDHT 06

Ø 16 - 42 mm | r1



Characteristics:    

Milling Cutter Bodies	Part no.	d ₁	l	r	l ₃	l ₂	l ₁	d ₂	d ₃	z
-----------------------	----------	----------------	---	---	----------------	----------------	----------------	----------------	----------------	---

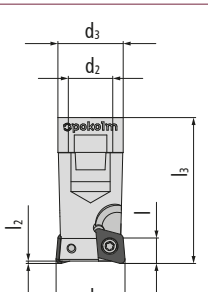
DuoPlug®										
	16 281 SG	16	6.5	1	31	1.3	–	M 10	15	2
	20 281 SG	20	6.5	1	31.5	1.3	–	M 12	18.5	3
	25 281 SG	25	6.5	1	37.5	1.3	–	M 16	23.5	4

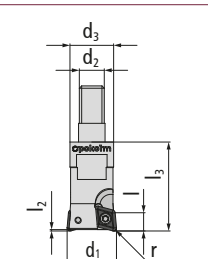
Threaded shank end mill body										
	16 281	16	6.5	1	28.5	1.3	–	M 8	13.8	2
	20 281	20	6.5	1	28.5	1.3	–	M 10	18	3
	25 281	25	6.5	1	32.5	1.3	–	M 12	21	4
	30 281	30	6.5	1	32.5	1.3	–	M 12	21	5
	35 281	35	6.5	1	42.5	1.3	–	M 16	29	6
	42 281	42	6.5	1	42.5	1.3	–	M 16	29	6

The accessories shown here must be used for all sizes!	Accessories	25 500	Torx screw	> Page 197
		07 500	Torx wrench	> Page 198
		SG25	TORQUE CliX-S grip	> Page 199
		TG55	TORQUE CliX-T grip	> Page 199
		DM09	Torque adapter 0.9 Nm	> Page 199
		T07-R	6-pack bits (Torx)	> Page 200

Indexable Inserts	Part no.	DIN designation	Quality	Coating	l	s	r	M
-------------------	----------	-----------------	---------	---------	---	---	---	---

	02 79 8035	XDHW 060210 SN	K10	PVTi	6.5	2.38	1	M 2.5
	02 79 892	XDHW 060210 SN	CBN for steel	uncoated	6.5	2.38	1	M 2.5
	02 79 894	XDHW 060210 SN	PKD	uncoated	6.5	2.38	1	M 2.5
	02 79 831P	XDHT 060210 EN	K10	Polished	6.5	2.38	1	M 2.5
	02 79 880	XDHT 060210 EN	K10	PVTi	6.5	2.38	1	M 2.5
	02 79 880 D	XDHW 060210 SN	K10	PVDiaN	6.5	2.38	1	M 2.5

Application data (fz / ap)

Material							
Coating grade	Feed rate/ Depth of cut	Steel	Stainless steel	Cast iron	NF metal and non-metals	High-temperature resistant alloys	Hardened materials
K10 PVTi	f _z (mm) a _p (mm)	0.1-0.2 0.1-0.55	0.1-0.2 0.1-0.25	0.1-0.3 0.1-1	–	–	0.1-0.2 0.1-0.55
CBN for steel uncoated	f _z (mm) a _p (mm)	–	–	–	–	–	0.1 0.1
PKD uncoated	f _z (mm) a _p (mm)	–	–	–	0.1-0.35 0.1-1	–	–
K10 Polished	f _z (mm) a _p (mm)	–	–	–	0.1-0.2 0.1-0.55	–	–
K10 PVTi	f _z (mm) a _p (mm)	–	–	–	0.1-0.2 0.1-0.55	–	–
K10 PVDiaN	f _z (mm) a _p (mm)	–	–	–	0.1-0.35 0.1-1	–	–

Spindle speed (Vc in m/min)

Material							
Coating grade	Application	Steel	Stainless steel	Cast iron	NF metal and non-metals	High-temperature resistant alloys	Hardened materials
K10 PVTi	Roughing Semi-Finish Finish	– ▽150 275 400 ▽150 275 400	– – ▽100 150 200	▽100 150 200 ▽150 225 300 ▽200 275 350	–	–	– ▽35 143 250 ▽35 143 250
CBN for steel uncoated	Roughing Semi-Finish Finish	–	–	–	–	–	– – ▽400 700 1000
PKD uncoated	Roughing Semi-Finish Finish	–	–	–	– ▽200 500 800 ▽400 700 1000	–	–
K10 Polished	Roughing Semi-Finish Finish	–	–	–	– ▽100 450 800 ▽100 450 800	–	–
K10 PVTi	Roughing Semi-Finish Finish	–	–	–	– ▽100 450 800 ▽100 450 800	–	–
K10 PVDiaN	Roughing Semi-Finish Finish	–	–	–	– ▽100 450 800 ▽100 450 800	–	–

Expanded application data

Full axial plunge

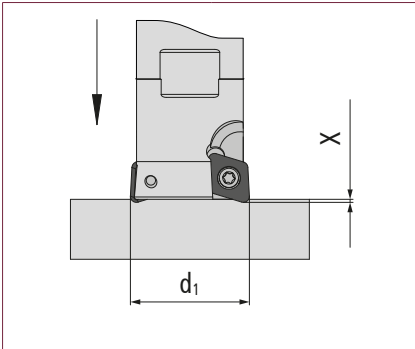

Arbor Ø d1	X _{max} mm
16-42	1.2

Full oblique plunge

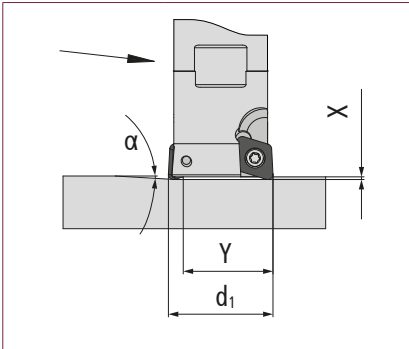

Arbor Ø d1	α°	y mm
16	<16.7	4
20	<8.5	8
25	<5.3	13
30	<3.8	18
35	<3.8	23
42	<2.3	30

Circular milling

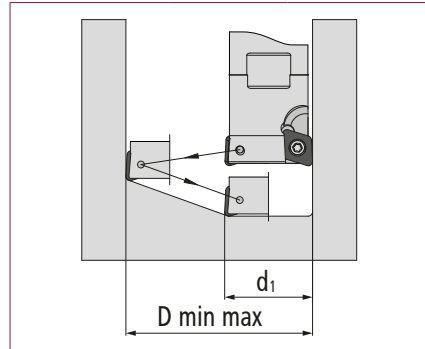

Arbor Ø d1	D _{min} mm	D _{max} mm
16	28	32
20	36	40
25	46	50
30	56	60
35	66	70
42	80	84

XDHW | XDHT 06

Ø 16 - 35 mm | r2



Characteristics:

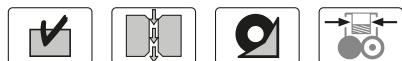

Milling Cutter Bodies	Part no.	d ₁	l	r	l ₃	l ₂	l ₁	d ₂	d ₃	z
-----------------------	----------	----------------	---	---	----------------	----------------	----------------	----------------	----------------	---

DuoPlug®

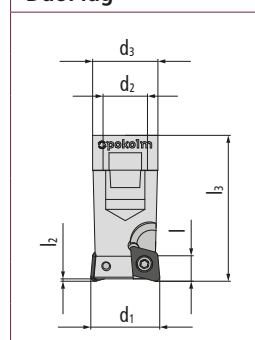

16 282 SG	16	6.5	2	31	1.3	-	M 10	15	2
20 282 SG	20	6.5	2	31.5	1.3	-	M 12	18.5	3
25 282 SG	25	6.5	2	37.5	1.3	-	M 16	23.5	4

Threaded shank end mill body

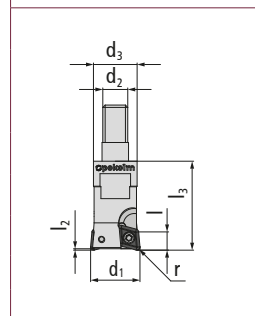

16 282	16	6.5	2	28.5	1.3	-	M 8	13.8	2
20 282	20	6.5	2	28.5	1.3	-	M 10	18	3
25 282	25	6.5	2	32.5	1.3	-	M 12	21	4
30 282	30	6.5	2	32.5	1.3	-	M 12	21	5
35 282	35	6.5	2	42.5	1.3	-	M 16	29	6

The accessories shown here must be used for all sizes!

Accessories

25 500	Torx screw	> Page 197
07 500	Torx wrench	> Page 198
SG25	TORQUE CliX-S grip	> Page 199
TG55	TORQUE CliX-T grip	> Page 199
DM09	Torque adapter 0.9 Nm	> Page 199
T07-R	6-pack bits (Torx)	> Page 200

Indexable Inserts	Part no.	DIN designation	Quality	Coating	l	s	r	M
-------------------	----------	-----------------	---------	---------	---	---	---	---

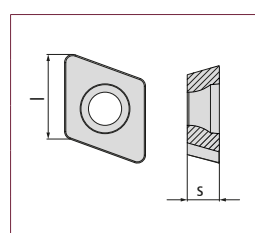

02 79 835 R2	XDHW 060220 SN	HSC 05	PVTi	6.5	2.38	2	M 2.5
--------------	----------------	--------	------	-----	------	---	-------

Application data (fz / ap)

Material							
Coating grade	Feed rate/ Depth of cut	Steel	Stainless steel	Cast iron	NF metal and non-metals	High-temperature resistant alloys	Hardened materials
HSC 05 PVTi	f _z (mm) a _p (mm)	0.1-0.2 0.1-0.55	0.1-0.2 0.1-0.25	0.1-0.3 0.1-1	–	–	0.1-0.2 0.1-0.55

Spindle speed (Vc in m/min)

Material							
Coating grade	Application	Steel	Stainless steel	Cast iron	NF metal and non-metals	High-temperature resistant alloys	Hardened materials
HSC 05 PVTi	Roughing Semi-Finish Finish	– ▼150 275 400 ▼150 275 400	– – ▽100 150 200	▼100 150 200 ▼150 225 300 ▼200 275 350	–	–	– ▼35 143 250 ▼35 143 250

Expanded application data

Full axial plunge	
Arbor Ø d1	X _{max} mm
16-35	1.2

Full oblique plunge		
Arbor Ø d1	α°	y mm
16	<16.7	4
20	<8.5	8
25	<5.3	13
30	<3.8	18
35	<3.8	23

Circular milling		
Arbor Ø d1	D _{min} mm	D _{max} mm
16	28	32
20	36	40
25	46	50
30	56	60
35	66	70

XDHW 10

Ø 25 - 80 mm | r1



Characteristics:

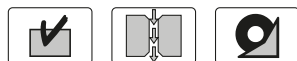

Milling Cutter Bodies	Part no.	d_1	l	r	l_3	l_2	l_1	d_2	d_3	z
-----------------------	----------	-------	-----	-----	-------	-------	-------	-------	-------	-----

Threaded shank end mill body

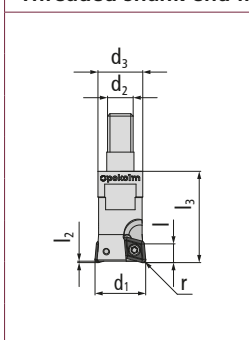

2 25 291	25	10	1	32	-	-	-	M 12	21	2
3 30 291	30	10	1	32	-	-	-	M 12	21	3
3 35 291	35	10	1	42	-	-	-	M 16	29	3
4 42 291	42	10	1	42	-	-	-	M 16	29	4

Shell-type milling cutter body

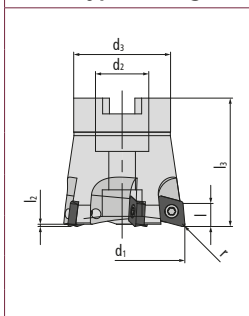

5 52 391	52	10	1	53	-	-	-	22	40	5
6 66 391	66	10	1	52	-	-	-	27	48	6
7 80 391	80	10	1	52	-	-	-	27	60	7

The accessories shown here must be used for all sizes!

Accessories

35 500	Torx screw	> Page 197
15 500	Torx wrench	> Page 198
SG25	TORQUE CliX-S grip	> Page 199
TG55	TORQUE CliX-T grip	> Page 199
DM25	Torque adapter 2.5 Nm	> Page 199
T15-R	6-pack bits (Torx)	> Page 200

Indexable Inserts	Part no.	DIN designation	Quality	Coating	l	s	r	M
-------------------	----------	-----------------	---------	---------	-----	-----	-----	-----

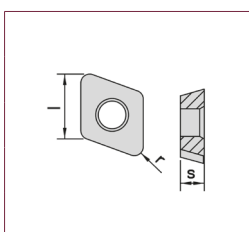

04 79 835	XDHW 10T310 SN	HSC 05	PVTi	10	3.97	1	M 3.5
-----------	----------------	--------	------	----	------	---	-------

Application data (fz / ap)

Material							
Coating grade	Feed rate/ Depth of cut	Steel	Stainless steel	Cast iron	NF metal and non-metals	High-temperature resistant alloys	Hardened materials
HSC 05 PVTi	f _z (mm) a _p (mm)	0.1-0.4 0.1-1.5	0.1-0.4 0.1-1.5	0.1-0.4 0.1-1.5	–	–	0.1-0.4 0.1-1.5

Spindle speed (Vc in m/min)

Material							
Coating grade	Application	Steel	Stainless steel	Cast iron	NF metal and non-metals	High-temperature resistant alloys	Hardened materials
HSC 05 PVTi	Roughing Semi-Finish Finish	– ▼150 275 400 ▼150 275 400	– – ▽100 150 200	▼100 150 200 ▼150 225 300 ▼200 275 350	–	–	– ▼35 143 250 ▼35 143 250



THINKING IN SOLUTIONS

Arbors for NF machining



VDGT - Arbors for NF machining

Finishing and pre-finishing specialist on vertical walls



Properties

- ideal for machining aluminum, copper, plastic, and graphite
- especially easy cutting
- high speeds
- high feed rates
- specially designed for machining situations on vertical walls
- **approach angle Kappa 90° / 93°**
- radius r 1 mm
- improved insert seat

Sizes	Page
k90° Ø 15 - 42 mm	138
k93° Ø 15 - 42 mm	140

Machining types

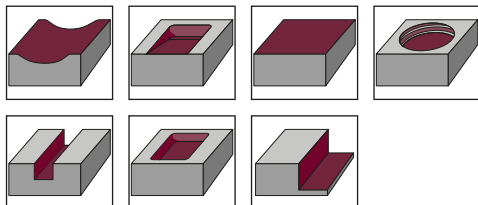

Connection types

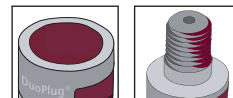

Cutting materials

Coating grade	ISO application						Application data (mm)		Cutting flute length	Thickness	Radius
	P	M	K	N	S	H	f _z	a _p	l (mm)	s (mm)	r (mm)
K10 Polished	-	-	-	▽	-	-	0.05 - 0.3	0.1 - 2.5	9.0	2.78	1
K10 PVTi	-	-	-	▽	-	-	0.05 - 0.3	0.1 - 2.5	9.0	2.78	1
K10 PVDiaN	-	-	-	▽	-	-	0.05 - 0.3	0.1 - 2.5	9.0	2.78	1

VDGT - K90°

Ø 15 - 42 mm | r1



Characteristics:

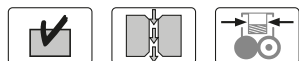

Milling Cutter Bodies	Part no.	d ₁	l	r	l ₃	l ₂	l ₁	d ₂	d ₃	z
-----------------------	----------	----------------	---	---	----------------	----------------	----------------	----------------	----------------	---

DuoPlug®

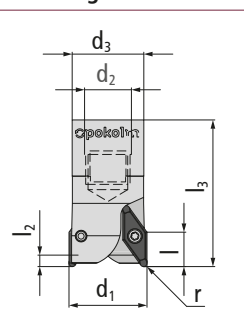

16 261 SG	16	9	1	38	4	-	M 10	15	2
20 261 SG	20	9	1	39.5	4	-	M 12	18.5	2
25 261 SG	25	9	1	42.5	4	-	M 16	23.5	3

Threaded shank end mill body

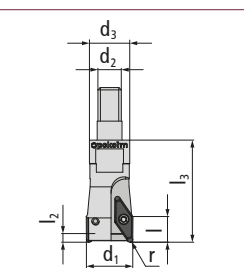

15 261	15	9	1	35.5	4	-	M 8	13.8	2
16 261	16	9	1	35	4	-	M 8	13.8	2
20 261	20	9	1	35.5	4	-	M 10	18	2
25 261	25	9	1	40	4	-	M 12	21	3
32 261	32	9	1	47.5	4	-	M 16	29	4
42 261	42	9	1	42.5	4	-	M 16	29	5

The accessories shown here must be used for all sizes!

Accessories

25 500	Torx screw	> Page 197
07 500	Torx wrench	> Page 198
SG25	TORQUE CliX-S grip	> Page 199
TG55	TORQUE CliX-T grip	> Page 199
DM09	Torque adapter 0.9 Nm	> Page 199
T07-R	6-pack bits (Torx)	> Page 200

Indexable Inserts

Part no.	DIN designation	Quality	Coating	l	s	r	M
----------	-----------------	---------	---------	---	---	---	---

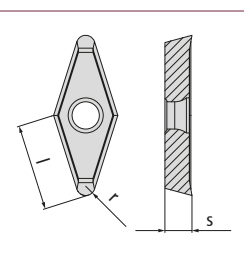

02 11 820	VDGT 11T210 FN	K10	Polished	9	2.78	1	M 2.5
02 11 860	VDGT 11T210 FN	K10	PVTi	9	2.78	1	M 2.5
02 11 860 D	VDGT 11T210 FN	K10	PVDiaN	9	2.78	1	M 2.5

Application data (fz / ap)

Material							
Coating grade	Feed rate/ Depth of cut	Steel	Stainless steel	Cast iron	NF metal and non-metals	High-temperature resistant alloys	Hardened materials
K10 Polished	f _z (mm) a _p (mm)	–	–	–	0.05-0.3 0.1-2.5	–	–
K10 PVTi	f _z (mm) a _p (mm)	–	–	–	0.05-0.3 0.1-2.5	–	–
K10 PVDiaN	f _z (mm) a _p (mm)	–	–	–	0.05-0.3 0.1-2.5	–	–

Spindle speed (Vc in m/min)

Material							
Coating grade	Application	Steel	Stainless steel	Cast iron	NF metal and non-metals	High-temperature resistant alloys	Hardened materials
K10 Polished	Roughing Semi-Finish Finish	–	–	–	▼100 1200 2400 ▼100 1200 2400 –	–	–
K10 PVTi	Roughing Semi-Finish Finish	–	–	–	▼100 1200 2400 ▼100 1200 2400 –	–	–
K10 PVDiaN	Roughing Semi-Finish Finish	–	–	–	▼100 1200 2400 ▼100 1200 2400 –	–	–

Expanded application data

Full axial plunge		Full oblique plunge			Circular milling		
Arbor Ø d1	X _{max} mm	Arbor Ø d1	α°	y mm	Arbor Ø d1	D _{min} mm	D _{max} mm
15-42	4	15	<63.4	2	15	26	30
		16	<45	4	16	28	32
		20	<26.6	8	20	36	40
		25	<17.1	13	25	46	50
		32	<11.3	20	32	60	64
		42	<7.6	30	42	80	84

VDGT - K93°

Ø 15 - 42 mm | r1



Milling Cutter Bodies	Part no.	d ₁	l	r	l ₃	l ₂	l ₁	d ₂	d ₃	z
-----------------------	----------	----------------	---	---	----------------	----------------	----------------	----------------	----------------	---

DuoPlug®

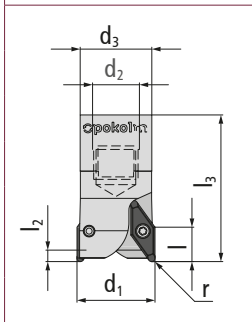

16 261-3 SG	16	9	1	38	4	–	M 10	15	2
20 261-3 SG	20	9	1	39.5	4	–	M 12	18.5	2
25 261-3 SG	25	9	1	42.5	4	–	M 16	23.5	3

Threaded shank end mill body

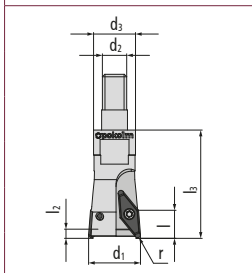

15 261-3	15	9	1	35	4	–	M 8	13.8	2
16 261-3	16	9	1	35.5	4	–	M 8	13.8	2
20 261-3	20	9	1	35.5	4	–	M 10	18	2
25 261-3	25	9	1	40	4	–	M 12	21	3
32 261-3	32	9	1	47.5	4	–	M 16	29	4
42 261-3	42	9	1	42.5	4	–	M 16	29	5

The accessories shown here must be used for all sizes!

Accessories

25 500	Torx screw	> Page 197
07 500	Torx wrench	> Page 198
SG25	TORQUE CliX-S grip	> Page 199
TG55	TORQUE CliX-T grip	> Page 199
DM09	Torque adapter 0.9 Nm	> Page 199
T07-R	6-pack bits (Torx)	> Page 200

Indexable Inserts

Part no.	DIN designation	Quality	Coating	l	s	r	M
----------	-----------------	---------	---------	---	---	---	---

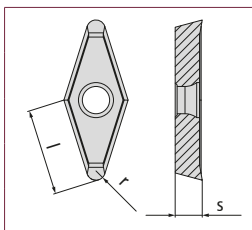

02 11 820	VDGT 11T210 FN	K10	Polished	9	2.78	1	M 2.5
02 11 860	VDGT 11T210 FN	K10	PVTi	9	2.78	1	M 2.5
02 11 860 D	VDGT 11T210 FN	K10	PVDiaN	9	2.78	1	M 2.5

Application data (fz / ap)

Material							
Coating grade	Feed rate/ Depth of cut	Steel	Stainless steel	Cast iron	NF metal and non-metals	High-temperature resistant alloys	Hardened materials
K10 Polished	f _z (mm) a _p (mm)	–	–	–	0.05-0.3 0.1-2.5	–	–
K10 PVTi	f _z (mm) a _p (mm)	–	–	–	0.05-0.3 0.1-2.5	–	–
K10 PVDiaN	f _z (mm) a _p (mm)	–	–	–	0.05-0.3 0.1-2.5	–	–

Spindle speed (Vc in m/min)

Material							
Coating grade	Application	Steel	Stainless steel	Cast iron	NF metal and non-metals	High-temperature resistant alloys	Hardened materials
K10 Polished	Roughing Semi-Finish Finish	–	–	–	▼100 1200 2400 ▼100 1200 2400 –	–	–
K10 PVTi	Roughing Semi-Finish Finish	–	–	–	▼100 1200 2400 ▼100 1200 2400 –	–	–
K10 PVDiaN	Roughing Semi-Finish Finish	–	–	–	▼100 1200 2400 ▼100 1200 2400 –	–	–

Expanded application data

Full axial plunge		Full oblique plunge			Circular milling		
Arbor Ø d1	X _{max} mm	Arbor Ø d1	α°	y mm	Arbor Ø d1	D _{min} mm	D _{max} mm
15-42	4	15	<63.4	2	15	26	30
		16	<45	4	16	28	32
		20	<26.6	8	20	36	40
		25	<17.1	13	25	46	50
		32	<11.3	20	32	60	64
		42	<7.6	30	42	80	84



VCGT - Arbors for
NF machining

WKO
Germany

VCGT - Arbors for NF machining

Roughing specialist for high speeds



Properties

- **Kappa k90° / k92°** for reliable machining of cavities without draft angle
- ideal for machining aluminum, copper, plastic, and graphite.
- especially easy cutting
- high speeds
- high feed rates
- radius r 3 mm

Sizes	Page
k90° Ø 32 - 80 mm	144
k92° Ø 32 - 125 mm	146

Machining types

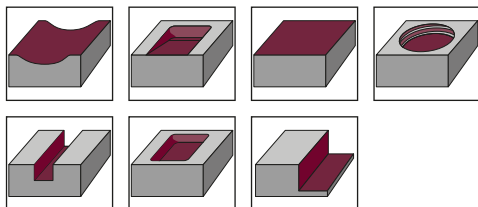

Connection types

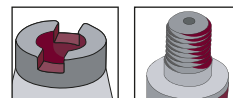

Cutting materials

Coating grade	ISO application						Application data (mm)		Cutting flute length	Thickness	Radius
	P	M	K	N	S	H	f _z	a _p	l (mm)	s (mm)	r (mm)
K10 Polished	-	-	-	▽	-	-	0.1 - 0.6	0.1 - 7.0	16	5.56	3
K10 PVTi	-	-	-	▽	-	-	0.1 - 0.6	0.1 - 2.5	16	5.56	3
K10 PVDiaN	-	-	-	▽	-	-	0.1 - 0.6	0.1 - 2.5	16	5.56	3

VCGT - K90°

Ø 32 - 80 mm | r3



Characteristics:



Milling Cutter Bodies	Part no.	d ₁	l	r	l ₃	l ₂	l ₁	d ₂	d ₃	z
-----------------------	----------	----------------	---	---	----------------	----------------	----------------	----------------	----------------	---

Threaded shank end mill body

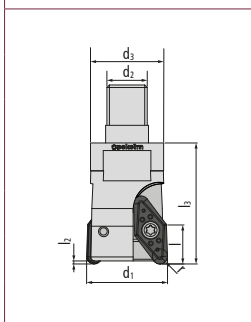

32 260-90	32	16	3	48	9.5	–	M 16	29	2
42 260-90	42	16	3	48	9.5	–	M 16	29	3

Shell-type milling cutter body

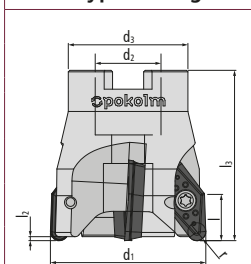

42 360	42	16	3	57	9.5	–	16	35	3	
Accessories	GWSTPS8ISK						Setscrew with interiorhexagon socket		> Page 198	
42 360-90	42	16	3	57	9.5	–	16	35	3	
52 360-90	52	16	3	57	9.5	–	22	40	3	
66 360-90	66	16	3	57	9.5	–	27	48	4	
80 360-90	80	16	3	57	9.5	–	27	60	5	

The accessories shown here must be used for all sizes!

Accessories

45 500	Torx screw	> Page 197
20 500	Torx wrench	> Page 198
SG25	TORQUE CliX-S grip	> Page 199
TG55	TORQUE CliX-T grip	> Page 199
DM55	Torque adapter 5.5 Nm	> Page 199
T20-R	6-pack bits (Torx)	> Page 200

Indexable Inserts	Part no.	DIN designation	Quality	Coating	l	s	r	M
-------------------	----------	-----------------	---------	---------	---	---	---	---

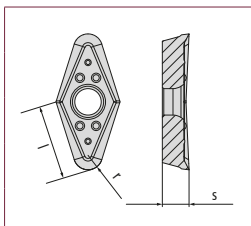

05 22 820	VCGT 220530 FN	K10	Polished	16	5.56	3	M 4.5
05 22 860	VCGT 220530 FN	K10	PVTi	16	5.56	3	M 4.5
05 22 860 D	VCGT 220530 FN	K10	PVDiaN	16	5.56	3	M 4.5

Application data (fz / ap)

Material							
Coating grade	Feed rate/ Depth of cut	Steel	Stainless steel	Cast iron	NF metal and non-metals	High-temperature resistant alloys	Hardened materials
K10 Polished	f _z (mm) a _p (mm)	–	–	–	0.1-0.6 0.1-7	–	–
K10 PVTi	f _z (mm) a _p (mm)	–	–	–	0.1-0.6 0.1-7	–	–
K10 PVDiaN	f _z (mm) a _p (mm)	–	–	–	0.1-0.6 0.1-7	–	–

Spindle speed (Vc in m/min)

Material							
Coating grade	Application	Steel	Stainless steel	Cast iron	NF metal and non-metals	High-temperature resistant alloys	Hardened materials
K10 Polished	Roughing Semi-Finish Finish	–	–	–	▼100 1200 2400 ▼100 1200 2400 –	–	–
K10 PVTi	Roughing Semi-Finish Finish	–	–	–	▼100 1200 2400 ▼100 1200 2400 –	–	–
K10 PVDiaN	Roughing Semi-Finish Finish	–	–	–	▼100 1200 2400 ▼100 1200 2400 –	–	–

Expanded application data

Full axial plunge		Full oblique plunge			Circular milling		
Arbor Ø d1	X _{max} mm	Arbor Ø d1	α°	y mm	Arbor Ø d1	D _{min} mm	D _{max} mm
32-80	9	32	<42	10	32	42	64
		42	<24.2	20	42	62	84
		52	<16.7	30	52	82	104
		66	<11.6	44	66	110	132
		80	<8.8	58	80	138	160

VCGT - K92°

Ø 32 - 125 mm | r3



Characteristics:



Milling Cutter Bodies	Part no.	d ₁	l	r	l ₃	l ₂	l ₁	d ₂	d ₃	z
-----------------------	----------	----------------	---	---	----------------	----------------	----------------	----------------	----------------	---

Threaded shank end mill body

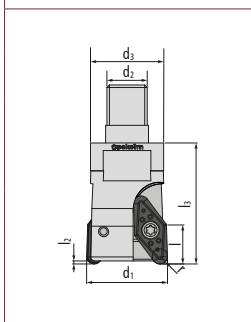

32 260	32	16	3	48	9.5	–	M 16	29	2
42 260	42	16	3	48	9.5	–	M 16	29	3

Shell-type milling cutter body

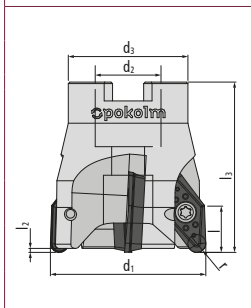

42 360	42	16	3	57	9.5	–	16	35	3	
Accessories	GWSTPS8ISK		Setscrew with interiorhexagon socket					> Page 198		
52 360	52	16	3	57	9.5	–	22	40	3	
66 360	66	16	3	57	9.5	–	27	48	4	
80 360	80	16	3	57	9.5	–	27	60	5	
100 360	100	16	3	57	9.5	–	32	70	6	
125 360	125	16	3	57	9.5	–	40	90	7	

The accessories shown here must be used for all sizes!

Accessories

45 500	Torx screw	> Page 197
20 500	Torx wrench	> Page 198
SG25	TORQUE CliX-S grip	> Page 199
TG55	TORQUE CliX-T grip	> Page 199
DM55	Torque adapter 5.5 Nm	> Page 199
T20-R	6-pack bits (Torx)	> Page 200

Indexable Inserts	Part no.	DIN designation	Quality	Coating	l	s	r	M
-------------------	----------	-----------------	---------	---------	---	---	---	---

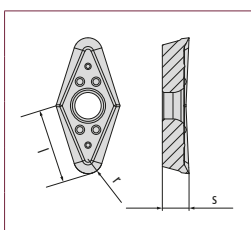

05 22 820	VCGT 220530 FN	K10	Polished	16	5.56	3	M 4.5
05 22 860	VCGT 220530 FN	K10	PVTi	16	5.56	3	M 4.5
05 22 860 D	VCGT 220530 FN	K10	PVDiaN	16	5.56	3	M 4.5

Application data (fz / ap)

Material							
Coating grade	Feed rate/ Depth of cut	Steel	Stainless steel	Cast iron	NF metal and non-metals	High-temperature resistant alloys	Hardened materials
K10 Polished	f _z (mm) a _p (mm)	–	–	–	0.1-0.6 0.1-7	–	–
K10 PVTi	f _z (mm) a _p (mm)	–	–	–	0.1-0.6 0.1-7	–	–
K10 PVDiaN	f _z (mm) a _p (mm)	–	–	–	0.1-0.6 0.1-7	–	–

Spindle speed (Vc in m/min)

Material							
Coating grade	Application	Steel	Stainless steel	Cast iron	NF metal and non-metals	High-temperature resistant alloys	Hardened materials
K10 Polished	Roughing Semi-Finish Finish	–	–	–	▼100 1200 2400 ▼100 1200 2400 –	–	–
K10 PVTi	Roughing Semi-Finish Finish	–	–	–	▼100 1200 2400 ▼100 1200 2400 –	–	–
K10 PVDiaN	Roughing Semi-Finish Finish	–	–	–	▼100 1200 2400 ▼100 1200 2400 –	–	–

Expanded application data

Full axial plunge		Full oblique plunge			Circular milling		
Arbor Ø d1	X _{max} mm	Arbor Ø d1	α°	y mm	Arbor Ø d1	D _{min} mm	D _{max} mm
32-125	9	32	<42	10	32	42	64
		42	<24.2	20	42	62	84
		52	<16.7	30	52	82	104
		66	<11.6	44	66	110	132
		80	<8.8	58	80	138	160
		100	<6.6	78	100	178	200
		125	<5.3	103	125	228	250

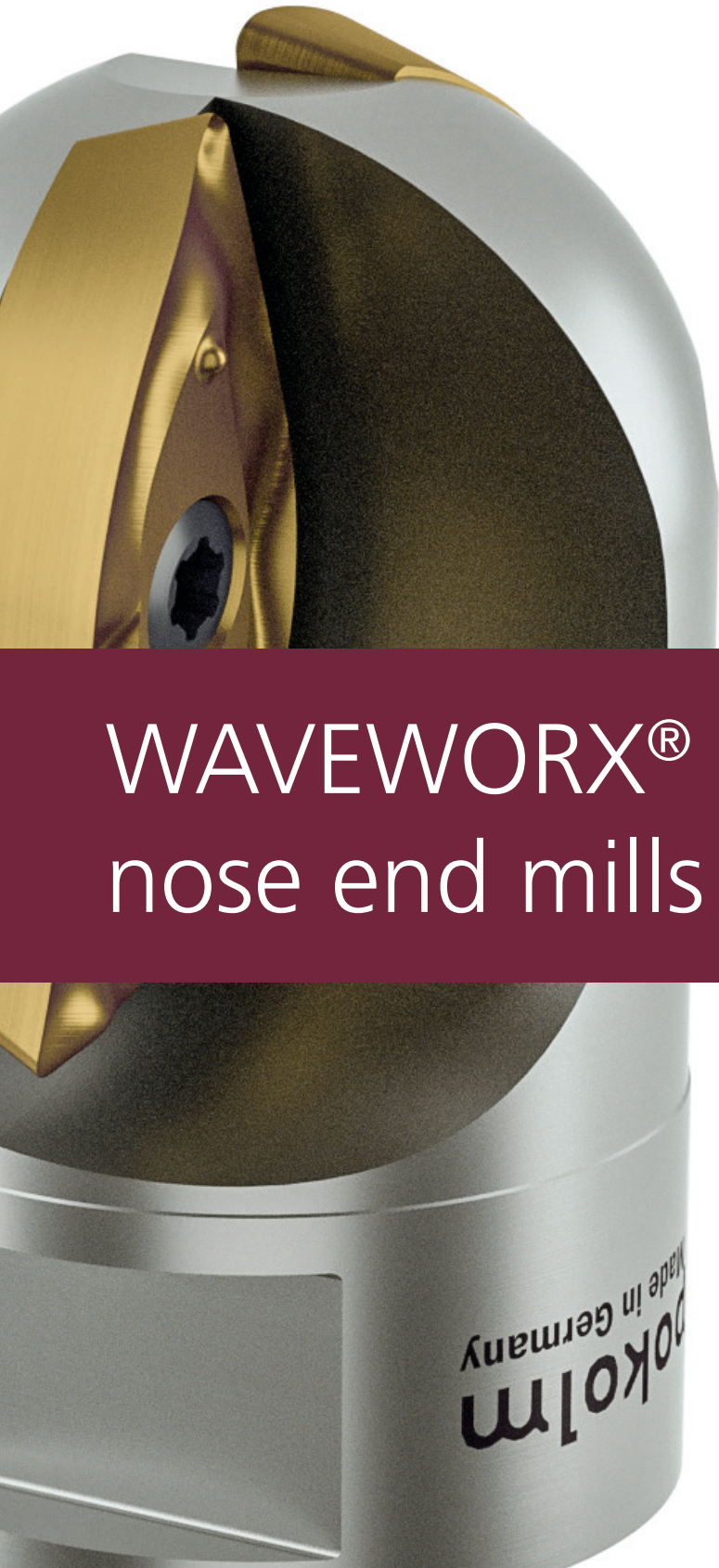

WAVEWORX® ball
nose end mills

WAVEWORX
Made in Germany

WAVEWORX® - ball nose end mills

Specialist for roughing work in steel



Properties

- roughing, remaining material machining and pre-finishing in steel
- for large working depths and low speeds
- with two effective cutting flutes for double the economic efficiency
- soft cut during roughing
- point cutting

Sizes	Page
Ø 16 mm - Ø 32 mm	150

Machining types

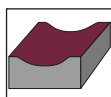

Connection types

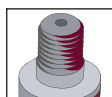

Deviation from IDEAL CONTOUR with Waveworx® ball nose roughing end mills

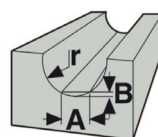

Profile deviation in center

Article	Quality / coating	r	d ₁	A	B
16 275	P25 / PVML	8	16	1.09	0.06
20 275	P25 / PVML	10	20	1.36	0.08
25 275	P25 / PVML	12.5	25	1.7	0.1
32 275	P25 / PVML	16	32	2.3	0.1

Cutting materials

Coating grade	ISO application						Application data (mm)		Length	Thickness	Radius
	P	M	K	N	S	H	f _z	a _p	l (mm)	s (mm)	r (mm)
P25 PVML	▽	-	-	-	-	-	0.1 - 0.6	0.6 - 3.0	15.6	3.18	8
							0.1 - 0.6	0.5 - 4.0	19.6	4.4	10
							0.2 - 0.8	0.5 - 4.0	24.5	5.0	12.5
							0.2 - 0.8	0.5 - 4.0	30.7	6.3	16

WAVEWORX®

Ø 16 mm - Ø 32 mm



Characteristics:



Milling Cutter Bodies	Part no.	d ₁	l	r	l ₃	l ₂	l ₁	d ₂	d ₃	z	
Threaded shank end mill body											
	16 275	16	15.6	8	24.7	–	–	M 8	13.8	2	
	Accessories	25 505	Torx screw for ball nose insert		> Page 197						
		08 500	*IP	Torx wrench		> Page 198					
		DM09	Torque adapter 0.9 Nm		> Page 199						
		T08-R	6-pack bits (Torx)		> Page 200						
	20 275	20	19.6	10	28.8	–	–	M 10	18	2	
	Accessories	30 505	Torx screw for ball nose insert		> Page 197						
		09 500	*IP	Torx wrench		> Page 198					
		DM15	Torque adapter 1.5 Nm		> Page 199						
		T09-R	6-pack bits (Torx)		> Page 200						
25 275	25	24.5	12.5	36.5	–	–	M 12	21	2		
Accessories	40 505 K	Torx screw		> Page 197							
	15 500	*IP	Torx wrench		> Page 198						
	DM38	Torque adapter 3.8 Nm		> Page 199							
	T15-R	6-pack bits (Torx)		> Page 200							
32 275	32	30.7	16	49.2	–	–	M 16	29	2		
Accessories	40 505	Torx screw		> Page 197							
	15 500	*IP	Torx wrench		> Page 198						
	DM38	Torque adapter 3.8 Nm		> Page 199							
	T15-R	6-pack bits (Torx)		> Page 200							
The accessories shown here must be used for all sizes!	Accessories	SG25	TORQUE CliX-S grip		> Page 199						
		TG25	TORQUE CliX-T grip		> Page 199						

Indexable Inserts	Part no.	DIN designation	Quality	Coating	l	s	r	M
	03 16 850	–	P25	PVML	15.6	3.18	8	M 2.5
	04 20 850	–	P25	PVML	19.6	4.4	10	M 3
	05 25 850	–	P25	PVML	24.5	5	12.5	M 4
	06 32 850	–	P25	PVML	30.7	6.3	16	M 4

Application data (fz / ap)

Material							
Coating grade	Feed rate/ Depth of cut	Steel	Stainless steel	Cast iron	NF metal and non-metals	High-temperature resistant alloys	Hardened materials
r=8 mm							
P25 PVML	f _z (mm) a _p (mm)	0.1-0.6 0.5-3	–	–	–	–	–
r=10 mm							
P25 PVML	f _z (mm) a _p (mm)	0.1-0.6 0.5-4	–	–	–	–	–
r=12.5 mm							
P25 PVML	f _z (mm) a _p (mm)	0.2-0.8 0.5-4	–	–	–	–	–
r=16 mm							
P25 PVML	f _z (mm) a _p (mm)	0.2-0.8 0.5-5	–	–	–	–	–

Spindle speed (Vc in m/min)

Material							
Coating grade	Application	Steel	Stainless steel	Cast iron	NF metal and non-metals	High-temperature resistant alloys	Hardened materials
P25 PVML	Roughing Semi-Finish Finish	▼100 200 300 ▼100 200 300 –	–	–	–	–	–

THINKING IN SOLUTIONS



Uniworx[®] – ball nose and toric end mills



UNIWORX® – ball nose and toric end mills

Universal milling cutter with maximum variations for finishing



Properties

- For ball nose / toric inserts
- V-shaped insert seat for frictional and positive-locking connections of tool cutter bodies, inserts, and fit screws
- Easily position the inserts
- Grind of the indexable inserts produced in one setup with helical flute ensures easy cutting and the best surface qualities
- Different coatings and cutting materials, specially customized for finishing

Sizes	Page
Ø 8 mm - Ø 20 mm	154

Machining types

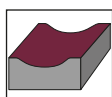

Connection types

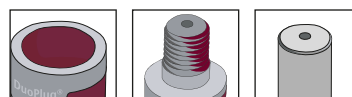





Cutting materials

Coating grade	ISO application						Application data (mm)		Diameter d (mm)	Thickness s (mm)	Radius Toric Ball r (mm)
	P	M	K	N	S	H	f _z	a _p			
HSC 05 PVTi / PVTiH	▽	▽	▽	▽	-	▽	0.08 - 0.16	0.1 - 0.3	8	2.0	3 4
							0.1 - 0.2	0.1 - 0.3	10	2.75	4 5
							0.12 - 0.24	0.1 - 0.3	12	3.3	5 6
							0.16 - 0.32	0.1 - 0.5	16	4.0	7 8
							0.2 - 0.4	0.1 - 0.5	20	5.0	8 10
CBN for cast iron	-	-	▽	-	-	-	0.1 - 0.2	0.1 - 0.2	8	2.0	3 -
							0.1 - 0.2	0.1 - 0.2	10	2.75	4 -
							0.1 - 0.2	0.1 - 0.2	12	3.3	5 -
							0.1 - 0.2	0.1 - 0.2	16	4.0	7 -
							0.1 - 0.2	0.1 - 0.2	20	5.0	8 -

UNIWORX®

Ø 8 mm - Ø 20 mm



Characteristics:    

Milling Cutter Bodies	Part no.	d ₁	d	r	l ₃	l ₂	l ₁	d ₂	d ₃	z
-----------------------	----------	----------------	---	---	----------------	----------------	----------------	----------------	----------------	---

DuoPlug®											
	10 214 SG	10	10	4 5	30.5	–	–	M 5	9.6	2	
	Accessories	35 520	Locating screw								> Page 197
		10 500	Torx wrench								> Page 198
		DM25	Torque adapter 2.5 Nm								> Page 199
		T10-R	Torque adapter 2.5 Nm								> Page 199
	12 214 SG	12	12	5 6	33.5	–	–	M 7	10.8	2	
	Accessories	40 520	Locating screw								> Page 197
		15 500	Torx wrench								> Page 198
		DM38	Torque adapter 3.8 Nm								> Page 199
		T15-R	6-pack bits (Torx)								> Page 200
	16 214 SG	16	16	7 8	40	–	–	M 10	15	2	
	Accessories	50 520	Locating screw								> Page 197
		20 500	Torx wrench								> Page 198
		DM55	Torque adapter 5.5 Nm								> Page 199
		T20-R	6-pack bits (Torx)								> Page 200
	20 214 SG	20	20	8 10	42.5	–	–	M 12	18.5	2	
Accessories	50 520	Locating screw								> Page 197	
	20 500	Torx wrench								> Page 198	
	DM55	Torque adapter 5.5 Nm								> Page 199	
	T20-R	6-pack bits (Torx)								> Page 200	

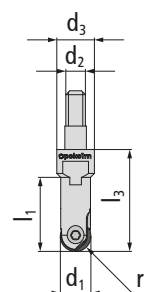
Threaded shank end mill body											
	08 214 M6	8	8	3 4	26	–	18.9	M 6	9.6	2	
	Accessories	30 522	Locating screw								> Page 197
		08 500	Torx wrench								> Page 198
		DM15	Torque adapter 1.5 Nm								> Page 199
		T08-R	6-pack bits (Torx)								> Page 200
	08 214	8	8	3 4	26	–	18.9	M 5	9.6	2	
	Accessories	30 522	Locating screw								> Page 197
		08 500	Torx wrench								> Page 198
		DM15	Torque adapter 1.5 Nm								> Page 199
		T08-R	6-pack bits (Torx)								> Page 200
	10 214 M6	10	10	4 5	24.5	–	–	M 6	9.75	2	
	Accessories	35 520	Locating screw								> Page 197
		10 500	Torx wrench								> Page 198
		DM25	Torque adapter 2.5 Nm								> Page 199
		T10-R	6-pack bits (Torx)								> Page 200
	10 214 SV	10	10	4 5	19	–	–	M 6	9.75	2	
Accessories	35 520	Locating screw								> Page 197	
	10 500	Torx wrench								> Page 198	
	DM25	Torque adapter 2.5 Nm								> Page 199	
	T10-R	6-pack bits (Torx)								> Page 200	
12 214 M6	12	12	5 6	28.5	–	–	M 6	11.5	2		
Accessories	40 520	Locating screw								> Page 197	
	15 500	Torx wrench								> Page 198	
	DM38	Torque adapter 3.8 Nm								> Page 199	
	T15-R	6-pack bits (Torx)								> Page 200	

Milling Cutter Bodies	Part no.	d_1	d	r	l_3	l_2	l_1	d_2	d_3	z	
Threaded shank end mill body											
	12 214 SV	12	12	5 6	21	–	–	M 6	11.5	2	
	Accessories	40 520	Locating screw							> Page 197	
		15 500	Torx wrench							> Page 198	
		DM38	Torque adapter 3.8 Nm							> Page 199	
		T15-R	6-pack bits (Torx)							> Page 200	
	16 214	16	16	7 8	36.5	–	–	M 8	13.8	2	
	Accessories	50 520	Locating screw							> Page 197	
		20 500	Torx wrench							> Page 198	
		DM55	Torque adapter 5.5 Nm							> Page 199	
		T20-R	6-pack bits (Torx)							> Page 200	
16 214 SV	16	16	7 8	25	–	–	M 8	13.8	2		
Accessories	50 520	Locating screw							> Page 197		
	20 500	Torx wrench							> Page 198		
	DM55	Torque adapter 5.5 Nm							> Page 199		
	T20-R	6-pack bits (Torx)							> Page 200		
20 214	20	20	8 10	37	–	–	M 10	18	2		
Accessories	50 520	Locating screw							> Page 197		
	20 500	Torx wrench							> Page 198		
	DM55	Torque adapter 5.5 Nm							> Page 199		
	T20-R	6-pack bits (Torx)							> Page 200		
20 214 SV	20	20	8 10	28	–	–	M 10	18	2		
Accessories	50 520	Locating screw							> Page 197		
	20 500	Torx wrench							> Page 198		
	DM55	Torque adapter 5.5 Nm							> Page 199		
	T20-R	6-pack bits (Torx)							> Page 200		
End mills											
	50 08 114	8	8	3 4	50	–	20	12	–	2	
	Accessories	30 522	Locating screw							> Page 197	
		08 500	Torx wrench							> Page 198	
		DM15	Torque adapter 1.5 Nm							> Page 199	
		T08-R	6-pack bits (Torx)							> Page 200	
	30 10 114	10	10	4 5	30	–	20	12	–	2	
	Accessories	35 520	Locating screw							> Page 197	
		10 500	Torx wrench							> Page 198	
		DM25	Torque adapter 1.5 Nm							> Page 199	
		T10-R	6-pack bits (Torx)							> Page 200	
50 12 114	12	12	5 6	50	–	50	12	–	2		
Accessories	40 520	Locating screw							> Page 197		
	20 500	Torx wrench							> Page 198		
	DM55	Torque adapter 3.8 Nm							> Page 199		
	T15-R	6-pack bits (Torx)							> Page 200		
60 16 114	16	16	7 8	60	–	26	20	–	2		
Accessories	50 520	Locating screw							> Page 197		
	15 500	Torx wrench							> Page 198		
	DM38	Torque adapter 5.5 Nm							> Page 199		
	T20-R	6-pack bits (Torx)							> Page 200		
80 20 114	20	20	8 10	80	–	80	20	–	2		
Accessories	50 520	Locating screw							> Page 197		
	20 500	Torx wrench							> Page 198		
	DM55	Torque adapter 5.5 Nm							> Page 199		
	T20-R	6-pack bits (Torx)							> Page 200		
Accessories	SG25	TORQUE CliX-S grip							> Page 199		
	TG55	TORQUE CliX-T grip							> Page 199		
Accessories shown here must be used for all sizes!											

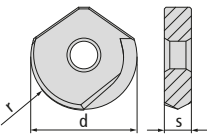
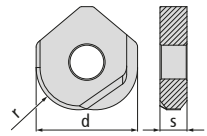
Indexable Inserts	Part no.	DIN designation	Quality	Coating	d	s	r	M
	08 835 V	ROHX 08T1	HSC 05	PVTi	8	2	4	M 3
	08 836 V	ROHX 08T1	HSC 05	PVTiH	8	2	4	M 3
	10 835 V	ROHX 10T2	HSC 05	PVTi	10	2.75	5	M 3.5
	10 836 V	ROHX 10T2	HSC 05	PVTiH	10	2.75	5	M 3.5
	12 835 V	ROHX 1233	HSC 05	PVTi	12	3.3	6	M 4
	12 836 V	ROHX 1233	HSC 05	PVTiH	12	3.3	6	M 4
	16 835 V	ROHX 16T3	HSC 05	PVTi	16	4	8	M 5
	16 836 V	ROHX 16T3	HSC 05	PVTiH	16	4	8	M 5
	16 836 V-1	RDHX16T3	HSC 05	PVTiH	16	4	8	M5
	20 835 V	ROHX 2050	HSC 05	PVTi	20	5	10	M 5
	20 836 V	ROHX 2050	HSC 05	PVTiH	20	5	10	M 5
	08 093 V R3	ROHX 08T1	CBN for cast iron	uncoated	8	2	3	M 3
	08 835 V R3	ROHX 08T1	HSC 05	PVTi	8	2	3	M 3
	08 836 V R3	ROHX 08T1	HSC 05	PVTiH	8	2	3	M 3
	10 093 V R4	ROHX 10T2	CBN for cast iron	uncoated	10	2.75	4	M 3.5
	10 835 V R4	ROHX 10T2	HSC 05	PVTi	10	2.75	4	M 3.5
	10 836 V R4	ROHX 10T2	HSC 05	PVTiH	10	2.75	4	M 3.5
	12 093 V R5	ROHX 1233	CBN for cast iron	uncoated	12	3.3	5	M 4
	12 835 V R5	ROHX 1233	HSC 05	PVTi	12	3.3	5	M 4
	12 836 V R5	ROHX 1233	HSC 05	PVTiH	12	3.3	5	M 4
	16 093 V R7	ROHX 16T3	CBN for cast iron	uncoated	16	4	7	M 5
	16 835 V R7	ROHX 16T3	HSC 05	PVTi	16	4	7	M 5
	16 836 V R7	ROHX 16T3	HSC 05	PVTiH	16	4	7	M 5
	20 836 V R8	ROHX 2050	HSC 05	PVTiH	20	5	8	M 5
	20 093 V R8	ROHX 2050	CBN for cast iron	uncoated	20	5	8	M 5

Application data (fz / ap)

Material							
Coating grade	Feed rate/ Depth of cut	Steel	Stainless steel	Cast iron	NF metal and non-metals	High-temperature resistant alloys	Hardened materials
d=8 mm							
HSC 05 PVTi	f _z (mm) a _p (mm)	0.08-0.12 0.1-0.2	0.04-0.08 0.05-0.1	0.08-0.12 0.1-0.2	0.08-0.12 0.1-0.2	–	0.08 0.1
HSC 05 PVTiH	f _z (mm) a _p (mm)	0.08-0.12 0.1-0.2	0.04-0.08 0.05-0.1	0.08-0.12 0.1-0.2	0.08-0.12 0.1-0.2	–	0.08 0.1
CBN for cast iron uncoated	f _z (mm) a _p (mm)	–	–	0.1-0.2 0.1-0.2	–	–	–
d=10 mm							
HSC 05 PVTi	f _z (mm) a _p (mm)	0.08-0.12 0.1-0.2	0.05-0.08 0.05-0.1	0.08-0.12 0.1-0.2	0.08-0.12 0.1-0.2	–	0.08 0.1
HSC 05 PVTiH	f _z (mm) a _p (mm)	0.08-0.12 0.1-0.2	0.05-0.1 0.05-0.1	0.08-0.12 0.1-0.2	0.08-0.12 0.1-0.2	–	0.08 0.1
CBN for cast iron uncoated	f _z (mm) a _p (mm)	–	–	0.1-0.2 0.1-0.2	–	–	–
d=12 mm							
HSC 05 PVTi	f _z (mm) a _p (mm)	0.12-0.18 0.1-0.2	0.06-0.12 0.05-0.15	0.12-0.18 0.1-0.2	0.12-0.18 0.1-0.2	–	0.12 0.1
HSC 05 PVTiH	f _z (mm) a _p (mm)	0.12-0.18 0.1-0.2	0.06-0.12 0.05-0.15	0.12-0.18 0.1-0.2	0.12-0.18 0.1-0.2	–	0.12 0.1
CBN for cast iron uncoated	f _z (mm) a _p (mm)	–	–	0.1-0.2 0.1-0.2	–	–	–
d=16 mm							
HSC 05 PVTi	f _z (mm) a _p (mm)	0.16-0.24 0.1-0.3	0.08-0.16 0.05-0.2	0.16-0.24 0.1-0.3	0.16-0.24 0.1-0.3	–	0.16 0.1
HSC 05 PVTiH	f _z (mm) a _p (mm)	0.16-0.24 0.1-0.3	0.08-0.16 0.05-0.2	0.16-0.24 0.1-0.3	0.16-0.24 0.1-0.3	–	0.16 0.1
CBN for cast iron uncoated	f _z (mm) a _p (mm)	–	–	0.1-0.2 0.1-0.2	–	–	–
d=20 mm							
HSC 05 PVTi	f _z (mm) a _p (mm)	0.08-0.3 0.1-0.2	0.08-0.2 0.05-0.2	0.08-0.12 0.1-0.2	0.08-0.12 0.1-0.2	–	0.08 0.1
HSC 05 PVTiH	f _z (mm) a _p (mm)	0.08-0.3 0.1-0.2	0.08-0.2 0.05-0.2	0.08-0.12 0.1-0.2	0.08-0.12 0.1-0.2	–	0.08 0.1
CBN for cast iron uncoated	f _z (mm) a _p (mm)	–	–	0.1-0.2 0.1-0.2	–	–	–

Spindle speed (Vc in m/min)

Material							
Coating grade	Application	Steel	Stainless steel	Cast iron	NF metal and non-metals	High-temperature resistant alloys	Hardened materials
HSC 05 PVTi	Roughing Semi-Finish Finish	– ▽150 275 400 ▽150 275 400	– – ▽100 150 200	– – ▽150 225 300 ▽200 275 350	– – ▽200 500 800 ▽100 450 800	–	– – ▽35 143 250
HSC 05 PVTiH	Roughing Semi-Finish Finish	– ▽150 275 400 ▽150 275 400	– – ▽100 150 200	– – ▽150 225 300 ▽200 275 350	– – ▽200 500 800 ▽200 500 800	–	– – ▽35 143 250
CBN for cast iron uncoated	Roughing Semi-Finish Finish	–	–	– ▽500 750 1000 ▽500 750 1000	–	–	–

THINKING IN SOLUTIONS

A90-PHK25710

Bull end / high feed milling cutters

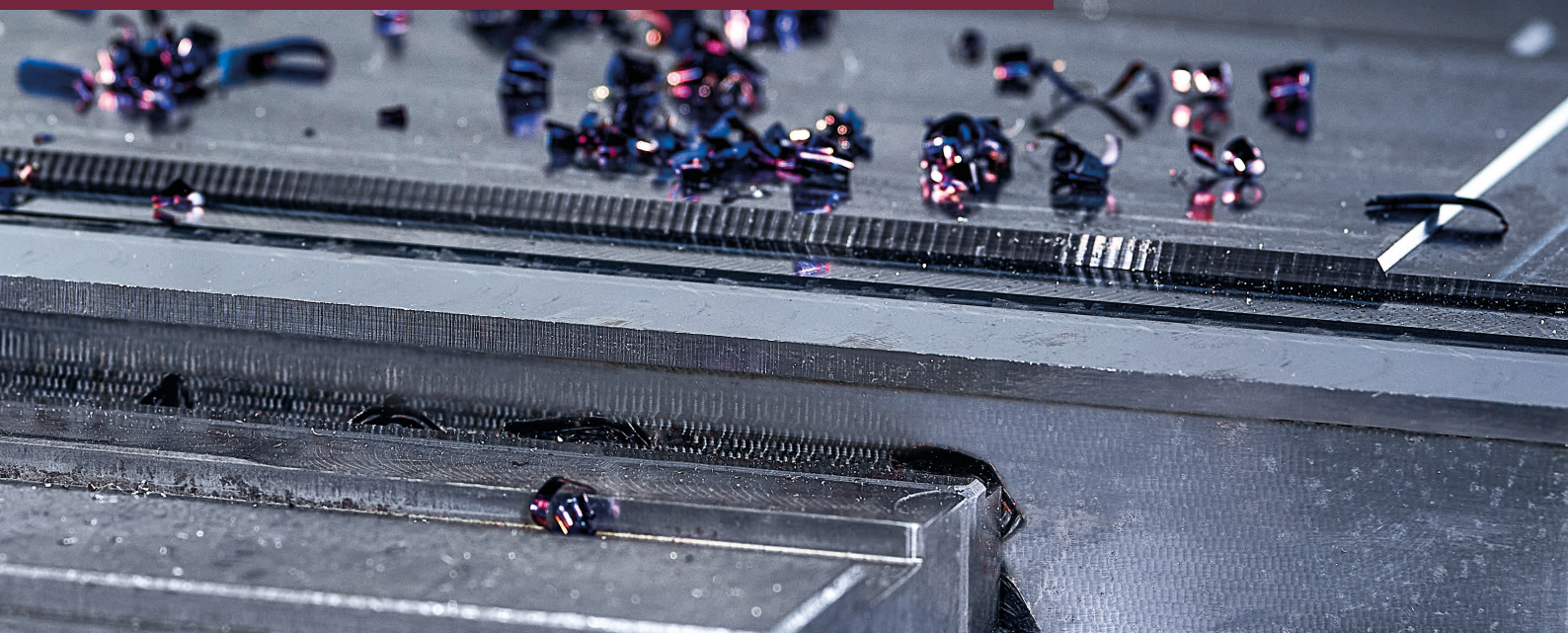

UNIWORX® PLUS – bull end / high feed milling cutters

**Universal milling cutter with maximum variations
for finishing**



Properties

- Innovative tool for roughing and finishing work in steel
- Roughing, remaining material machining with high-feed indexable inserts in steel
- Precision-ground bull end inserts for high-precision finishing
- Asymmetrical contact surfaces for error-free positioning
- Unique coolant feed with compartment opening through the indexable insert

Sizes	Page
Ø 10 - 20 mm, r0.5 r1.0	160
Ø 10 - 20 mm, HF	163

Machining types

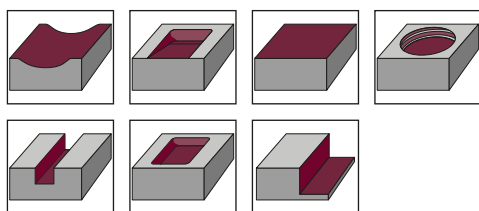

Connection types

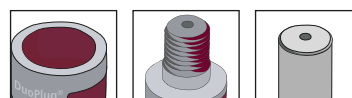





Cutting materials

Coating grade K10 PPTi	ISO application						Application data (mm)		Diameter	Thickness	Radius
	P	M	K	N	S	H	f_z	a_p	d (mm)	s (mm)	r (mm)
Bull end Cutters	▽	▽	▽	▽	▽	▽	0.05 - 0.5	0.05 - 1.2	10	2.5	0.5
	▽	▽	▽	▽	▽	▽	0.05 - 0.4	0.05 - 1.3	12	2.5	0.5
	▽	▽	▽	▽	▽	▽	0.05 - 0.55	0.05 - 1.5	16	3.0	1.0
	▽	▽	▽	▽	▽	▽	0.05 - 0.55	0.05 - 1.8	20	3.0	1.0
High feed cutter	▽	▽	▽	▽	▽	▽	0.1 - 0.75	0.05 - 0.5	10	2.5	–
	▽	▽	▽	▽	▽	▽	0.1 - 0.9	0.1 - 0.6	12	2.5	–
	▽	▽	▽	▽	▽	▽	0.15 - 1.2	0.1 - 0.8	16	3.0	–
	▽	▽	▽	▽	▽	▽	0.15 - 1.5	0.1 - 1.0	20	3.0	–

UNIWORX® Plus

diam 10 - 20 mm - r 0.5 | r 1.0

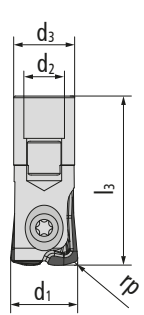
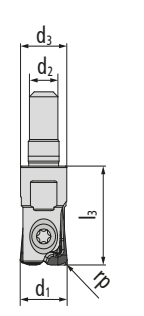

Characteristics:    

Milling Cutter Bodies	Part no.	d ₁	d	r	l ₃	l ₂	l ₁	d ₂	d ₃	z	
DuoPlug®											
	10 215 SG	10	10	0.5	30	–	–	M 7	9.6	2	
	Accessories	30 530	Locating screw							> Page 197	
		08 500	Torx wrench							> Page 198	
		DM15	Torque adapter 1.5 Nm							> Page 199	
		T08-R	6-pack bits (Torx)							> Page 200	
	12 215 SG	12	12	0.5	30	–	–	M 7	10.8	2	
	Accessories	35 530	Locating screw							> Page 197	
		10 500	Torx wrench							> Page 198	
		DM25	Torque adapter 2.5 Nm							> Page 199	
		T10-R	6-pack bits (Torx)							> Page 200	
	16 215 SG	16	16	1	38	–	–	M 10	15	2	
	Accessories	50 530	Locating screw							> Page 197	
		20 500	Torx wrench							> Page 198	
		DM55	Torque adapter 5.5 Nm							> Page 199	
		T20-R	6-pack bits (Torx)							> Page 200	
	20 215 SG	20	20	1	43	–	–	M 12	18.6	2	
Accessories	50 530	Locating screw							> Page 197		
	20 500	Torx wrench							> Page 198		
	DM55	Torque adapter 5.5 Nm							> Page 199		
	T20-R	6-pack bits (Torx)							> Page 200		
Threaded shank end mill body											
	10 215 M6	10	10	0.5	20	–	–	M 6	9.75	2	
	Accessories	30 530	Locating screw							> Page 197	
		08 500	Torx wrench							> Page 198	
		DM15	Torque adapter 1.5 Nm							> Page 199	
		T08-R	6-pack bits (Torx)							> Page 200	
	12 215 M6	12	12	0.5	20	–	–	M 6	11.5	2	
	Accessories	35 530	Locating screw							> Page 197	
		10 500	Torx wrench							> Page 198	
		DM25	Torque adapter 2.5 Nm							> Page 199	
		T10-R	6-pack bits (Torx)							> Page 200	
	16 215	16	16	1	25	–	–	M 8	13.8	2	
	Accessories	50 530	Locating screw							> Page 197	
		20 500	Torx wrench							> Page 198	
		DM55	Torque adapter 5.5 Nm							> Page 199	
		T20-R	6-pack bits (Torx)							> Page 200	
	20 215	20	20	1	30	–	–	M 10	18	2	
Accessories	50 530	Locating screw							> Page 197		
	20 500	Torx wrench							> Page 198		
	DM55	Torque adapter 5.5 Nm							> Page 199		
	T20-R	6-pack bits (Torx)							> Page 200		

Milling Cutter Bodies	Part no.	d_1	d	r	l_3	l_2	l_1	d_2	d_3	z
-----------------------	----------	-------	-----	-----	-------	-------	-------	-------	-------	-----

End mills										
	40 10 115 G	10	10	0.5	40	–	80	10	9.8	2
	Accessories	30 522	Locating screw							> Page 197
		08 500	Torx wrench							> Page 198
		DM15	Torque adapter 1.5 Nm							> Page 199
		T08-R	6-pack bits (Torx)							> Page 200
	48 12 115 G	12	12	0.5	48	–	93	12	11.8	2
Accessories	35 520	Locating screw							> Page 197	
	10 500	Torx wrench							> Page 198	
	DM25	Torque adapter 2.5 Nm							> Page 199	
	T10-R	6-pack bits (Torx)							> Page 200	
	64 16 115 G	16	16	1	64	–	112	16	13.8	2
Accessories	50 520	Locating screw							> Page 197	
	20 500	Torx wrench							> Page 198	
	DM55	Torque adapter 5.5 Nm							> Page 199	
	T10-R	6-pack bits (Torx)							> Page 200	
	80 20 115 G	20	20	1	80	–	130	20	18	2
Accessories	50 520	Locating screw							> Page 197	
	20 500	Torx wrench							> Page 198	
	DM55	Torque adapter 5.5 Nm							> Page 199	
	T10-R	6-pack bits (Torx)							> Page 200	
The accessories shown here must be used for all sizes!	Accessories	SG25	TORQUE CliX-S grip							> Page 199
		TG55	TORQUE CliX-T grip							> Page 199

<2/2

Indexable Inserts	Part no.	DIN designation	Quality	Coating	d	s	r	M
-------------------	----------	-----------------	---------	---------	-----	-----	-----	-----

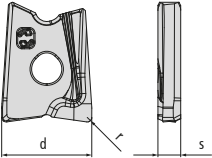
	15 10 8060 R05	XOGX 102505 ER	K10	PPTi	10	2.5	0.5	M 3
	15 12 8060 R05	XOGX 122505 ER	K10	PPTi	12	2.5	0.5	M 3.5
	15 16 8060 R10	XOGX 163010 ER	K10	PPTi	16	3	1	M 5
	15 20 8060 R10	XOGX 203010 ER	K10	PPTi	20	3	1	M 5

Application data (fz / ap)

Material							
Coating grade	Feed rate/ Depth of cut	Steel	Stainless steel	Cast iron	NF metal and non-metals	High-temperature resistant alloys	Hardened materials
d=10 mm							
K10 PPTi	f _z (mm) a _p (mm)	0.05-0.3 0.05-0.6	0.05-0.15 0.05-0.2	0.05-0.35 0.05-0.5	0.05-0.5 0.05-1.2	0.05-0.12 0.05-0.15	0.05-0.25 0.05-0.3
d=12 mm							
K10 PPTi	f _z (mm) a _p (mm)	0.05-0.35 0.05-0.7	0.05-0.15 0.05-0.3	0.05-0.4 0.05-0.6	0.05-0.55 0.05-1.3	0.05-0.15 0.05-0.2	0.05-0.25 0.05-0.35
d=16 mm							
K10 PPTi	f _z (mm) a _p (mm)	0.05-0.35 0.05-0.8	0.05-0.15 0.05-0.3	0.05-0.4 0.05-0.8	0.05-0.55 0.05-1.5	0.05-0.15 0.05-0.2	0.05-0.25 0.05-0.4
d=20 mm							
K10 PPTi	f _z (mm) a _p (mm)	0.05-0.35 0.05-1	0.05-0.15 0.05-0.3	0.05-0.4 0.05-1	0.05-0.55 0.05-1.8	0.05-0.15 0.05-0.2	0.05-0.25 0.05-0.42

Spindle speed (Vc in m/min)

Material							
Coating grade	Application	Steel	Stainless steel	Cast iron	NF metal and non-metals	High-temperature resistant alloys	Hardened materials
K10 PPTi	Roughing Semi-Finish Finish	– ▽110 160 210 ▽120 210 300	– – ▽100 165 230	– ▽140 205 270 ▽170 240 310	– ▽200 450 700 ▽300 550 800	– – ▽40 75 110	– ▽80 130 180 ▽100 150 200

UNIWORX® Plus

Ø 10 - 20 mm - HF



Characteristics:

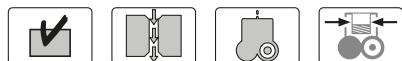

Milling Cutter Bodies	Part no.	d_1	d	r_p^*	l_3	l_2	l_1	d_2	d_3	z
-----------------------	----------	-------	-----	---------	-------	-------	-------	-------	-------	-----

DuoPlug®

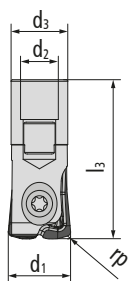

10 215 SG	10	10	1	30	-	-	M 7	9.6	2
Accessories	30 530	Locating screw		> Page 197					
	08 500	Torx wrench		> Page 198					
	DM15	Torque adapter 1.5 Nm		> Page 199					
	T08-R	6-pack bits (Torx)		> Page 200					
12 215 SG	12	12	1.3	30	-	-	M 7	10.8	2
Accessories	35 530	Locating screw		> Page 197					
	10 500	Torx wrench		> Page 198					
	DM25	Torque adapter 2.5 Nm		> Page 199					
	T10-R	6-pack bits (Torx)		> Page 200					
16 215 SG	16	16	1.7	38	-	-	M 10	15	2
Accessories	50 530	Locating screw		> Page 197					
	20 500	Torx wrench		> Page 198					
	DM55	Torque adapter 5.5 Nm		> Page 199					
	T20-R	6-pack bits (Torx)		> Page 200					
20 215 SG	20	20	1.95	43	-	-	M 12	18.6	2
Accessories	50 530	Locating screw		> Page 197					
	20 500	Torx wrench		> Page 198					
	DM55	Torque adapter 5.5 Nm		> Page 199					
	T20-R	6-pack bits (Torx)		> Page 200					

Threaded shank end mill body

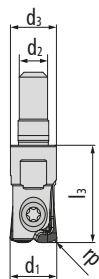

10 215 M6	10	10	1	20	-	-	M 6	9.75	2
Accessories	30 530	Locating screw		> Page 197					
	08 500	Torx wrench		> Page 198					
	DM15	Torque adapter 1.5 Nm		> Page 199					
	T08-R	6-pack bits (Torx)		> Page 200					
12 215 M6	12	12	1.3	20	-	-	M 6	11.5	2
Accessories	35 530	Locating screw		> Page 197					
	10 500	Torx wrench		> Page 198					
	DM25	Torque adapter 2.5 Nm		> Page 199					
	T10-R	6-pack bits (Torx)		> Page 200					
16 215	16	16	1.7	25	-	-	M 8	13.8	2
Accessories	50 530	Locating screw		> Page 197					
	20 500	Torx wrench		> Page 198					
	DM55	Torque adapter 5.5 Nm		> Page 199					
	T20-R	6-pack bits (Torx)		> Page 200					
20 215	20	20	1.95	30	-	-	M 10	18	2
Accessories	50 530	Locating screw		> Page 197					
	20 500	Torx wrench		> Page 198					
	DM55	Torque adapter 5.5 Nm		> Page 199					
	T20-R	6-pack bits (Torx)		> Page 200					

* Bull end to be programmed

UNIWORX® PLUS – BULL END / HIGH FEED CUTTERS

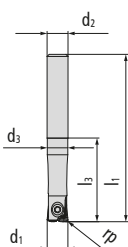

Milling Cutter Bodies		Part no.	d_1	d	r_p^*	l_3	l_2	l_1	d_2	d_3	z
End mills											
	40 10 115 G	10	10	1	40	–	80	10	9.8	2	
	Accessories	30 522	Locating screw								> Page 197
		08 500	Torx wrench								> Page 198
		DM15	Torque adapter 1.5 Nm								> Page 199
		T08-R	6-pack bits (Torx)								> Page 200
48 12 115 G	12	12	1.3	48	–	93	12	11.8	2		
Accessories	35 520	Locating screw								> Page 197	
	10 500	Torx wrench								> Page 198	
	DM25	Torque adapter 2.5 Nm								> Page 199	
	T10-R	6-pack bits (Torx)								> Page 200	
64 16 115 G	16	16	1.7	64	–	112	16	13.8	2		
Accessories	50 520	Locating screw								> Page 197	
	20 500	Torx wrench								> Page 198	
	DM55	Torque adapter 5.5 Nm								> Page 199	
	T20-R	6-pack bits (Torx)								> Page 200	
80 20 115 G	20	20	1.95	80	–	130	20	18	2		
Accessories	50 520	Locating screw								> Page 197	
	20 500	Torx wrench								> Page 198	
	DM55	Torque adapter 5.5 Nm								> Page 199	
	T20-R	6-pack bits (Torx)								> Page 200	
The accessories shown here must be used for all sizes!	Accessories	SG25	TORQUE CliX-S grip								> Page 199
		TG55	TORQUE CliX-T grip								> Page 199

<2/2

Indexable Inserts		Part no.	DIN designation	Quality	Coating	l	s	r_p^*	M
	15 10 8060 HF	XOGX 1025 ER	K10	PPTi	10	2.5	1	M 3	
	15 12 8060 HF	XOGX 1225 ER	K10	PPTi	12	2.5	1.3	M 3.5	
	15 16 8060 HF	XOGX 1630 ER	K10	PPTi	16	3	1.7	M 5	
	15 20 8060 HF	XOGX 2030 ER	K10	PPTi	20	3	1.95	M 5	

* Bull end to be programmed

Application data (fz / ap)

Material							
Coating grade	Feed rate/ Depth of cut	Steel	Stainless steel	Cast iron	NF metal and non-metals	High-temperature resistant alloys	Hardened materials
d=10 mm							
--K10 PPTi	f _z (mm) a _p (mm)	0.1-0.75 0.05-0.4	0.1-0.28 0.05-0.15	0.1-0.75 0.05-0.4	0.1-0.75 0.05-0.5	0.1-0.22 0.05-0.15	0.1-0.55 0.05-0.25
d=12 mm							
K10 PPTi	f _z (mm) a _p (mm)	0.1-0.9 0.1-0.5	0.1-0.32 0.1-0.2	0.1-0.9 0.1-0.5	0.1-0.9 0.1-0.6	0.1-0.32 0.1-0.2	0.1-0.7 0.05-0.35
d=16 mm							
K10 PPTi	f _z (mm) a _p (mm)	0.15-1.2 0.1-0.6	0.15-0.4 0.1-0.25	0.15-1.2 0.1-0.6	0.15-1.2 0.1-0.8	0.1-0.4 0.1-0.25	0.1-0.8 0.1-0.45
d=20 mm							
K10 PPTi	f _z (mm) a _p (mm)	0.15-1.5 0.1-0.8	0.15-0.5 0.1-0.35	0.15-1.5 0.1-0.8	0.15-1.5 0.1-1	0.1-0.5 0.1-0.35	0.1-1 0.1-0.6

Spindle speed (Vc in m/min)

Material							
Coating grade	Application	Steel	Stainless steel	Cast iron	NF metal and non-metals	High-temperature resistant alloys	Hardened materials
K10 PPTi	Roughing Semi-Finish Finish	▽90 140 190 ▽110 160 210 -	- ▽80 135 190 -	▽120 180 240 ▽140 205 270 -	▽150 375 600 ▽200 450 700 -	- ▽30 50 70 -	▽80 120 160 ▽100 140 180 -

Technical information

When **CAD/CAM programming** the tool geometry, a milling cutter with theoretical **bull end (r_p)** must be used. Values and information on the unmachined area of **remaining material (t)** are provided in the table. The **tool length is measured** on the flat diameter "**d_p**".

∅	r _p	t
10	1.00	0.300
12	1.30	0.379
16	1.70	0.570
20	1.95	0.720

THINKING IN SOLUTIONS



High feed cutters

SLOTWORX HP[®] high feed cutters

**High-performance machining
in hard materials processing**



Properties

- indexable insert quality for machining soft and hard materials with different coatings
- real bull end for near-contour work
- high-precision ground indexable inserts
- maximum cutter body stability thanks to negative axial angle
- high number of teeth on the smallest tool diameter
- can replace solid carbide tools in some areas

Sizes	Page
S: Ø 12 - 48 mm	168
M: Ø 16 - 52 mm	172

Machining types

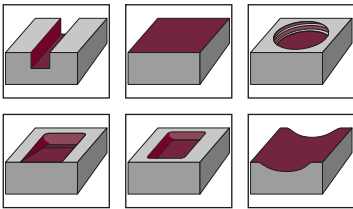

Connection types

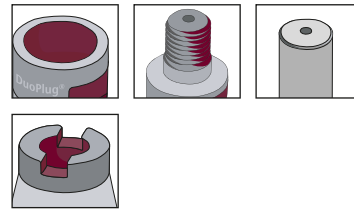

Cutting materials

Coating grade	ISO application						Application data (mm)		Cutting flute length	Thickness	Radius
	P	M	K	N	S	H	f _z	a _p	l (mm)	s (mm)	r (mm)
HSC 05 PVTi	▽	-	▽	-	-	▽	0.05 - 0.7	0.05 - 0.4	6.2	2.2	2
HSC 05 PVDiaN	-	-	-	▽	-	-	0.05 - 0.7	0.05 - 0.4	6.2	2.2	2
HSC 05 PVTiH	▽	-	▽	-	-	▽	0.05 - 0.7	0.05 - 0.4	6.2	2.2	2
K10 Polished	-	-	-	▽	-	-	0.05 - 0.7	0.05 - 1.0	6.2	2.2	2
K10 PVTi	-	▽	-	▽	-	-	0.02 - 1.0	0.02 - 1.0	6.2	2.2	2
M40 PVST	-	▽	-	-	▽	-	0.03 - 0.6	0.05 - 1.0	6.2	2.2	2
P30PATG	▽	-	-	-	-	-	0.8 - 1.5	0.4 - 1.0	9.95	3.2	8
K10PVTi	-	-	▽	-	-	▽	0.5 - 1.8	0.15 - 1.25	9.95	3.2	8

SLOTWORX® HP

HP | Size S - Ø 10 - 32 mm



Characteristics:

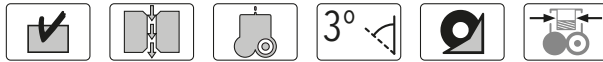

Milling Cutter Bodies	Part no.	d_1	l	r	l_3	l_2	l_1	d_2	d_3	z
-----------------------	----------	-------	-----	-----	-------	-------	-------	-------	-------	-----

DuoPlug®

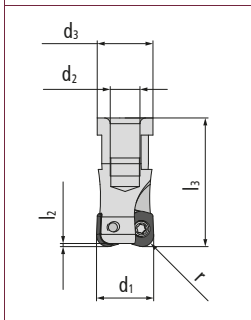

3 12 266 SG	12	6.2	2	28	0.7	–	M 7	10.8	3
4 16 266 SG	16	6.2	2	31	0.7	–	M 10	15	4
5 20 266 SG	20	6.2	2	33	0.7	–	M 12	18.6	5
5 25 266 SG	25	6.2	2	35	0.7	–	M 16	23.5	5

Threaded shank end mill body

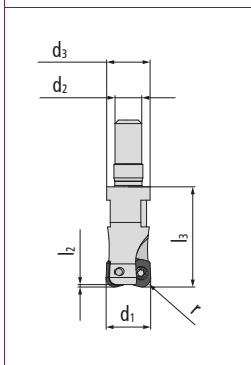

2 10 266 M6	10	6.2	2	22.5	0.7	–	M 6	9.75	2
3 12 266 M6	12	6.2	2	22.5	0.7	–	M 6	11.5	3
4 16 266	16	6.2	2	27.5	0.7	–	M 8	13.8	4
5 20 266	20	6.2	2	27.5	0.7	–	M 10	18	5
5 25 266	25	6.2	2	32	0.7	–	M 12	21	5
7 32 266	32	6.2	2	32	0.7	–	M 16	29	7

End mills

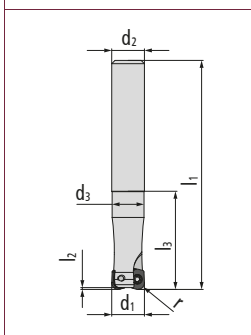

2 30 10 166 G	10	6.2	2	30	0.7	70	10	9.75	2
3 36 12 166 G	12	6.2	2	36	0.7	81	12	11.5	3
4 48 16 166 G	16	6.2	2	48	0.7	96	16	15.5	4

The accessories shown here must be used for all sizes!

Accessories

21 500 P	Torx screw	> Page 197
06 500 P	Torx wrench (Torx Plus)	> Page 198
SG25	TORQUE CLIX-S grip	> Page 199
TG55	TORQUE CLIX-T grip	> Page 199
DM06	Torque adapter 0.6 Nm	> Page 199
TP06-R	6-pack bits (Torx Plus)	> Page 200

Indexable Inserts	Part no.	DIN designation	Quality	Coating	l	s	r	M
	02 66 835 R20	XCHW 062220 EN	HSC 05	PVTi	6.2	2.2	2	M 2
	02 66 835 R20 D	XCHW 062220 EN	HSC 05	PVDiaN	6.2	2.2	2	M 2
	02 66 836 R20	XCHW 062220 EN	HSC 05	PVTiH	6.2	2.2	2	M 2
	02 66 820 R20	XCHT 062220 FN	K10	Polished	6.2	2.2	2	M 2
	02 66 860 R20	XCHT 062220 FN	K10	PVTi	6.2	2.2	2	M 2
	02 66 890 R20	XCHT 062220 EN	M40	PVST	6.2	2.2	2	M 2

Application data (f_z / a_p)

Material							
Coating grade	Feed rate/ Depth of cut	Steel	Stainless steel	Cast iron	NF metal and non-metals	High-temperature resistant alloys	Hardened materials
HSC 05 PVTi	f _z (mm) a _p (mm)	0.05-0.7 0.05-0.4	–	0.05-0.7 0.05-0.4	–	–	0.05-0.6 0.05-0.4
HSC 05 PVDiaN	f _z (mm) a _p (mm)	–	–	–	0.05-0.7 0.05-1	–	–
HSC 05 PVTiH	f _z (mm) a _p (mm)	0.05-0.7 0.05-0.4	–	0.05-0.7 0.05-0.4	–	–	0.05-0.6 0.05-0.4
K10 Polished	f _z (mm) a _p (mm)	–	–	–	0.02-1 0.05-1	–	–
K10 PVTi	f _z (mm) a _p (mm)	–	0.02-0.4 0.02-0.3	–	0.02-1 0.05-1	0.02-0.1 0.02-0.15	–
M40 PVST	f _z (mm) a _p (mm)	–	0.03-0.6 0.05-1	–	–	0.03-0.6 0.05-1	–

Spindle speed (V_c in m/min)

Material							
Coating grade	Application	Steel	Stainless steel	Cast iron	NF metal and non-metals	High-temperature resistant alloys	Hardened materials
HSC 05 PVTi	Roughing Semi-Finish Finish	▼120 185 250 ▼150 275 400 ▼150 275 400	–	▼100 150 200 ▼150 225 300 ▼200 275 350	–	–	▼35 143 250 ▼35 143 250 ▼35 143 250
HSC 05 PVDiaN	Roughing Semi-Finish Finish	–	–	–	▼200 500 800 ▼200 500 800 ▼200 500 800	–	–
HSC 05 PVTiH	Roughing Semi-Finish Finish	▼120 185 250 ▼150 275 400 ▼150 275 400	–	▼100 150 200 ▼150 225 300 ▼200 275 350	–	–	▼35 143 250 ▼35 143 250 ▼35 143 250
K10 Polished	Roughing Semi-Finish Finish	–	–	–	▼100 450 800 ▼100 450 800 ▼100 450 800	–	–
K10 PVTi	Roughing Semi-Finish Finish	–	▼90 120 150 ▼120 150 180	–	▼100 450 800 ▼100 450 800 ▼100 450 800	–	–
M40 PVST	Roughing Semi-Finish Finish	–	▼80 130 180 ▼100 155 210 ▼120 185 250	–	–	▼30 55 80 ▼40 65 90 ▼60 90 120	–

Expanded application data

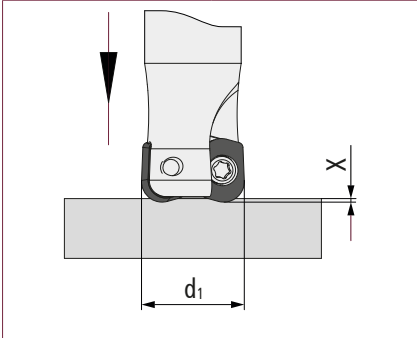
Full axial plunge	
	
Arbor Ø d1	X _{max} mm
10-32	0.7

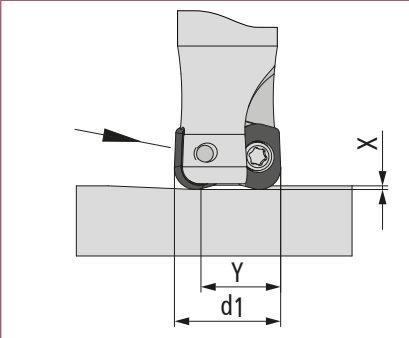
Full oblique plunge		
		
Arbor Ø d1	α°	y mm
10	<2.5	4
12	<2	6
16	<1.6	10
20	<1.2	14
25	<1	19
32	<1	26

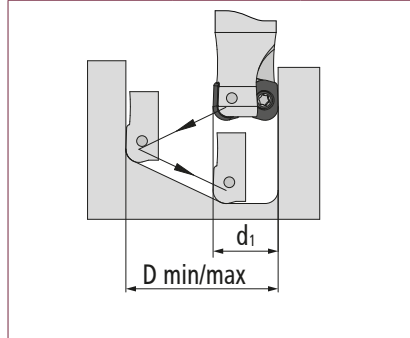



Circular milling		
		
Arbor Ø d1	D _{min} mm	D _{max} mm
10	13	20
12	17	24
16	25	32
20	33	39
25	43	49
32	57	63



SLOTWORX® HP

HP | size M - Ø 16 - 52 mm



Characteristics:    

Milling Cutter Bodies	Part no.	d_1	l	r_p^*	l_3	l_2	l_1	d_2	d_3	z
-----------------------	----------	-------	-----	---------	-------	-------	-------	-------	-------	-----

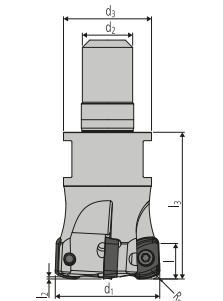
Threaded shank end mill body										
	HP06-016-E08-02	16	9.95	2	25	1.8	–	M 8	13.8	2
	HP06-020-E10-03	20	9.95	2	30	1.8	–	M 10	18	3
	HP06-025-E12-03	25	9.95	2	35	1.8	–	M 12	21	3
	HP06-025-E12-04	25	9.95	2	35	1.8	–	M 12	21	4
	HP06-032-E16-04	32	9.95	2	40	1.8	–	M 16	29	4
	HP06-032-E16-05	32	9.95	2	40	1.8	–	M 16	29	5
	HP06-035-E16-05	35	9.95	2	40	1.8	–	M 16	29	5

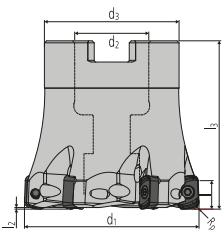
Shell-type milling cutter body										
	HP06-042-A16-05	42	9.95	2	40	1.8	–	16	35	5
	HP06-042-A16-07	42	9.95	2	40	1.8	–	16	35	7
	HP06-052-A22-05	52	9.95	2	50	1.8	–	22	40	5
	HP06-052-A22-07	52	9.95	2	50	1.8	–	22	40	7

<p>The accessories shown here must be used for all sizes!</p>	<p>Accessories</p>	25 550	Torx screw	> Page 197
		08 500	Torx wrench	> Page 198
		SG25	TORQUE ClIX-S grip	> Page 199
		TG55	TORQUE ClIX-T grip	> Page 199
		DM09	Torque adapter 0.9 Nm	> Page 199
		T08-R	6-pack bits (Torx)	> Page 200

Indexable Inserts	Part no.	DIN designation	Quality	Coating	l	s	r	M
-------------------	----------	-----------------	---------	---------	-----	-----	-----	-----

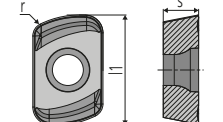
	HP06-8058-HF-RP	EPHT 0603	P30	PATG	9.95	3.2	8	M 2.5
	HP06-8068-HF-RK	EPHT 0603	K10	PVTi	9.95	3.2	8	M 2.5

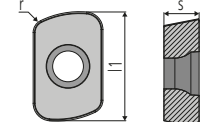
	HP06-8052-HF-RP	EPEW 0603	P30	PATG	9.95	3.2	8	M 2.5
	HP06-8062-HF-RK	EPEW 0603	K10	PVTi	9.95	3.2	8	M 2.5

* Bull end to be programmed

Application data (fz / ap)

Material							
Coating grade	Feed rate/ Depth of cut	Steel	Stainless steel	Cast iron	NF metal and non-metals	High-temperature resistant alloys	Hardened materials
P30 PATG	f _z (mm) a _p (mm)	0.8-1.5 0.4-1	-	-	-	-	-
K10 PVTi	f _z (mm) a _p (mm)	-	-	1.2-1.8 0.4-1.25	-	-	0.5-1 0.15-0.4

Spindle speed (Vc in m/min)

Material							
Coating grade	Application	Steel	Stainless steel	Cast iron	NF metal and non-metals	High-temperature resistant alloys	Hardened materials
P30 PATG	Roughing	▽90 135 180	-	-	-	-	-
	Semi-Finish	▽100 145 190	-	-	-	-	-
	Finish	-	-	-	-	-	-
K10 PVTi	Roughing	-	-	▽90 135 180	-	-	▽65 80 95
	Semi-Finish	-	-	▽100 145 190	-	-	▽70 85 100
	Finish	-	-	-	-	-	-

Extended operation data

Axial immersion in full			Oblique immersion in full			Circular milling		
Milling Cutter Ø d1	d _p	X _{max} mm	Milling Cutter Ø d1	α°	y mm	Milling Cutter Ø d1	D _{min} mm	D _{max} mm
16	7.16	0.7	16	4	12	16	25	32
20	11.16	0.7	20	3	16	20	33	40
25	16.16	0.7	25	2.5	21	25	43	50
32	23.16	0.7	32	1.7	28	32	57	64
35	26.16	0.7	35	1.5	31	35	63	70
42	33.16	0.7	42	1.2	38	42	77	84
52	43.16	0.7	52	1	48	52	97	104

Technical information

When **CAD/CAM programming** the tool geometry, a milling cutter with theoretical **bull end (r_p) 2.0 mm** must be used. The unmachined area of **remaining material (t)** is 0.46 mm. The **tool length is measured** on the flat diameter "d_p".



SLOTWORX®
high feed cutter

made in Germany
OKO

SLOTWORX® high feed cutter

With state of the art cutting flute geometry for universal applications



Properties

- for high-feed hard machining of all materials up to 60+2HRC
- PVTiH coating is particularly well-suited for machining die-making steels like 1.2714
- extremely long service life and smooth running thanks to customized clamping surface geometry

Sizes	Page
M: Ø 16 - 52 mm	176

Practical video
SLOTWORX® M
High Feed
in 1.2738



Machining types

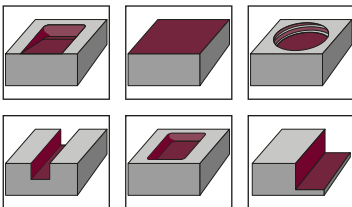

Connection types

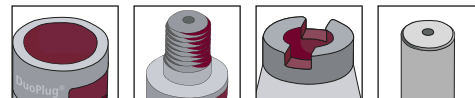

Cutting materials

Coating grade	ISO application						Application data (mm)		Cutting flute length l (mm)	Thickness s (mm)	bull end to be programmed (mm) r _p
	P	M	K	N	S	H	f _z	a _p			
HSC 05 PVTi	▽	-	▽	-	-	▽	0.3 - 1.8	0.1 - 0.7	10	3.58	1.4
HSC 05 PVTiH	▽	-	▽	-	-	▽	0.3 - 1.8	0.1 - 0.7	10	3.58	1.4
P40 PVGO	▽	-	-	-	-	-	0.3 - 1.5	0.5 - 1.6	10	3.58	1.4
K10 PVGP	-	-	▽	-	-	▽	0.15 - 1.2	0.2 - 1.5	10	3.58	1.4
M40 PVST	▽	▽	-	-	▽	-	0.15 - 1.5	0.15 - 1.0	10	3.58	1.4
M35 PCTC	-	▽	-	-	▽	-	0.15 - 1.0	0.15 - 0.75	10	3.58	1.4

SLOTWORX®-K15°

HF | size M - Ø 16 - 52 mm



Characteristics:



Milling Cutter Bodies	Part no.	d ₁	l	r	l ₃	l ₂	l ₁	d ₂	d ₃	z
-----------------------	----------	----------------	---	---	----------------	----------------	----------------	----------------	----------------	---

DuoPlug®

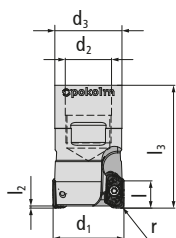

2 16 267 SG	16	10	1.4	38	2.5	–	M 10	15	2		
2 20 267 SG	20	10	1.4	40	2.5	–	M 12	18.6	2		
3 25 267 SG	25	10	1.4	43	2.5	–	M 16	23.5	3		
Accessories	25 505 KP	Screw for Slotworx M Ø 16; 20; 25						> Page 197			

Threaded shank end mill body

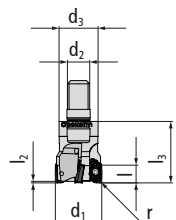

2 16 267	16	10	1.4	29	2.5	–	M 8	13.8	2		
2 20 267	20	10	1.4	29	2.5	–	M 10	18	2		
3 20 267	20	10	1.4	29	2.5	–	M 10	18	3		
3 25 267	25	10	1.4	33	2.5	–	M 12	21	3		
4 25 267	25	10	1.4	33	2.5	–	M 12	21	4		
Accessories	25 505 KP	Screw for Slotworx M Ø 16; 20; 25						> Page 197			
4 32 267	32	10	1.4	43	2.5	–	M 16	29	4		
5 32 267	32	10	1.4	43	2.5	–	M 16	29	5		
5 42 267	42	10	1.4	43	2.5	–	M 16	29	5		
Accessories	25 505 P	Screw for Slotworx M Ø 32; 42; 52						> Page 197			

End mills

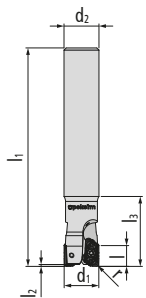

2 32 16 167 G	16	10	1.4	32	2.5	165	16	–	2		
3 40 20 167 G	20	10	1.4	40	2.5	165	20	–	3		
3 50 25 167 G	25	10	1.4	50	2.5	225	25	–	3		
4 50 25 167 G	25	10	1.4	50	2.5	225	25	–	4		
Accessories	25 505 KP	Screw for Slotworx M Ø 16; 20; 25						> Page 197			

Milling Cutter Bodies	Part no.	d_1	l	r	l_3	l_2	l_1	d_2	d_3	z
-----------------------	----------	-------	-----	-----	-------	-------	-------	-------	-------	-----

Shell-type milling cutter body

	5 42 367	42	10	1.4	43	2.5	–	16	35	5
	6 52 367	52	10	1.4	53	2.5	–	22	40	6
	Accessories	25 505 P Screw for Slotworx M Ø 32; 42; 52						> Page 197		

The accessories shown here must be used for all sizes!

Accessories

08 500 P	Torx wrench (Torx Plus)	> Page 198
SG25	TORQUE CliX-S grip	> Page 199
TG55	TORQUE CliX-T grip	> Page 199
DM09	Torque adapter 0.9 Nm	> Page 199
TP08-R	6-pack bits (Torx Plus)	> Page 200

<2/2

Indexable Inserts	Part no.	DIN designation	Quality	Coating	l	s	r	M
-------------------	----------	-----------------	---------	---------	-----	-----	-----	-----

	04 67 835 HF	XDEW 10T3 SR	HSC 05	PVTi	10	3.58	1.4	M 2.5
	04 67 836 HF	XDEW 10T3 SR	HSC 05	PVTiH	10	3.58	1.4	M 2.5
	04 67 848 HF	XDMT 10T3 TR	P40	PVGO	10	3.58	1.4	M 2.5
	04 67 862 HF	XDMT 10T3 TR	K10	PVGP	10	3.58	1.4	M 2.5
	04 67 896 HF	XDMT 10T3 ER	M40	PVST	10	3.58	1.4	M 2.5
	04 67 8099 HF	XDMT 10T3 ER	M35	PCTC	10	3.58	1.4	M 2.5

Application data (f_z / a_p)

Material							
Coating grade	Feed rate/ Depth of cut	Steel	Stainless steel	Cast iron	NF metal and non-metals	High-temperature resistant alloys	Hardened materials
HSC 05 PVTi	f_z (mm) a_p (mm)	0.5-1.6 0.15-0.7	–	0.4-1.8 0.15-0.7	–	–	0.3-1 0.1-0.5
HSC 05 PVTiH	f_z (mm) a_p (mm)	0.5-1.6 0.15-0.7	–	0.4-1.8 0.15-0.7	–	–	0.3-1 0.1-0.5
P40 PVGO	f_z (mm) a_p (mm)	0.3-1.5 0.5-1.6	–	–	–	–	–
K10 PVGP	f_z (mm) a_p (mm)	–	–	0.3-1.2 0.2-1.5	–	–	0.15-1 0.2-1
M40 PVST	f_z (mm) a_p (mm)	0.3-1.5 0.15-1	0.15-1.4 0.15-0.75	–	–	0.1-0.9 0.15-0.65	–
M35 PCTC	f_z (mm) a_p (mm)	–	0.15-1 0.15-0.75	–	–	0.1-0.9 0.15-0.65	–

Spindle speed (Vc in m/min)

Material							
Coating grade	Application	Steel	Stainless steel	Cast iron	NF metal and non-metals	High-temperature resistant alloys	Hardened materials
HSC 05 PVTi	Roughing Semi-Finish Finish	▼120 185 250 ▼150 275 400 -	-	▼100 150 200 ▼150 225 300 -	-	-	▼35 143 250 ▼35 143 250 -
HSC 05 PVTiH	Roughing Semi-Finish Finish	▼120 185 250 ▼150 275 400 -	-	▼100 150 200 ▼150 225 300 -	-	-	▼35 143 250 ▼35 143 250 -
P40 PVGO	Roughing Semi-Finish Finish	▼100 150 200 ▼100 150 200 -	-	-	-	-	-
K10 PVGP	Roughing Semi-Finish Finish	-	-	▼150 185 220 ▼160 190 220 -	-	-	▼80 115 150 ▼100 150 200 -
M40 PVST	Roughing Semi-Finish Finish	▼80 140 200 ▼100 150 200 -	▼80 130 180 ▼100 155 210 -	-	-	▼30 55 80 ▼40 65 90 -	-
M35 PCTC	Roughing Semi-Finish Finish	-	▼110 155 200 ▼120 175 230 -	-	-	▼30 65 100 ▼40 75 110 -	-

Expanded application data

Full axial plunge	
Arbor Ø d1	X _{max} mm
16-52	0.85

Full oblique plunge		
Arbor Ø d1	α°	y mm
16	4	12
20	3	16
25	2.5	21
32	1.7	28
42	1.2	38
52	1	41.3

Circular milling		
Arbor Ø d1	D _{min} mm	D _{max} mm
16	26	32
20	34	40
25	44	50
32	58	64
42	78	84
52	98	104





FOURWORX®
high feed cutter



FOURWORX® high feed cutter

With more power at speed, feed rate, and depth of cut



Properties

- 4 x more power
- highest number of teeth on the smallest diameter
- 4 cutting flutes per insert
- ideal for unstable components and in deep cavities
- 3D chip groove for excellent chip removal

Sizes	Page
Ø 16 mm - 42 mm	182

Machining types

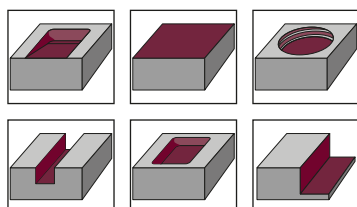

Connection types

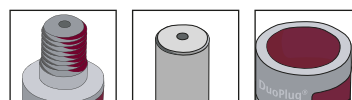

Cutting materials

Coating grade	ISO application						Application data (mm)		Length	Thickness	Radius
	P	M	K	N	S	H	f _z	a _p	l (mm)	s (mm)	r (mm)
P40 PCSR	▽	-	▽	-	-	-	0.2-1.1	0.05-0.75	9	2.5	1
P40 PPGO	▽	-	▽	-	-	-	0.25-1.2	0.1-0.75	9	2.5	1
M40 PPST	▽	-	▽	-	-	▽	0.15-1	0.05-0.7	9	2.5	1
K10 PPTi	▽	▽	-	-	▽	-	0.1-1.2	0.1-0.75	9	2.5	1

FOURWORX®

Size S - Ø 16 - 42 mm



Characteristics:



Milling Cutter Bodies	Part no.	d_1	l	r_p^*	l_3	l_2	l_1	d_2	d_3	z
-----------------------	----------	-------	-----	---------	-------	-------	-------	-------	-------	-----

DuoPlug®

	FR05-016-D10-03	16	9	1.4*	35	0.35	–	M 10	15	2
	FR05-020-D12-04	20	9	1.4*	35	0.4	–	M 12	18.6	2
	FR05-025-D16-05	25	9	1.4*	40	0.45	–	M 16	23.5	2

Threaded shank end mill body

	FR05-016-E08-02	16	9	1.4*	29	0.35	–	M 8	13.8	2
	FR05-016-E08-03	16	9	1.4*	29	0.35	–	M 8	13.8	3
	FR05-020-E10-04	20	9	1.4*	29	0.4	–	M 10	18	4
	FR05-025-E12-05	25	9	1.4*	33	0.45	–	M 12	21	5
	FR05-032-E16-05	32	9	1.4*	42	0.5	–	M 16	29	5
	FR05-035-E16-06	35	9	1.4*	42	0.5	–	M 16	29	6
	FR05-042-E16-06	42	9	1.4*	42	0.55	–	M 16	29	6

End mills

	FR05-016-Z16-03-32	16	9	1.4*	32	0.35	80	16	13.8	3
	FR05-020-Z20-04-40	20	9	1.4*	40	0.4	90	20	18	4

The accessories shown here must be used for all sizes!

Accessories

22 500 P	Torx screw	> Page 197
07 500 P	Torx wrench	> Page 198
SG25	TORQUE CLIX-S grip	> Page 199
TG55	TORQUE CLIX-T grip	> Page 199
DM06	Torque adapter 0.6 Nm	> Page 199
TP07-R	6-pack bits (Torx Plus)	> Page 200

* Bull end to be programmed

Indexable Inserts	Part no.	DIN designation	Quality	Coating	l	s	r	M
	FR05-8242-HF-RP	LNKX 0925 ZSR	P40	PATM	9	2.5	1	M 2.2
	FR05-8048-HF-RP	LNKX 0925 ZSR	P40	PPGO	9	2.5	1	M 2.2
	FR05-8062-HF-RK	LNKX 0925 ZSR	K10	PPTi	9	2.5	1	M 2.2
	FR05-8242-HF-MP	LNKX 0925 ZER	P40	PATM	9	2.5	1	M 2.2
	FR05-8096-HF-MM	LNKX 0925 ZER	M40	PPST	9	2.5	1	M 2.2

Application data (fz / ap)

Material							
Coating grade	Feed rate/ Depth of cut	Steel	Stainless steel	Cast iron	NF metal and non-metals	High-temperature resistant alloys	Hardened materials
Size S LNKX M							
P40 PATM	f _z (mm) a _p (mm)	0.25-1 0.05-0.7	–	0.2-0.95 0.05-0.6	–	–	–
M40 PPST	f _z (mm) a _p (mm)	0.25-1 0.05-0.6	0.25-1 0.05-0.6	–	–	0.15-0.75 0.05-0.6	–
Size S LNKX R							
P40 PATM	f _z (mm) a _p (mm)	0.3-1.2 0.1-0.75	–	0.25-1.1 0.1-0.7	–	–	–
P40 PPGO	f _z (mm) a _p (mm)	0.3-1.2 0.1-0.75	–	0.25-1.1 0.1-0.7	–	–	–
K10 PPTi	f _z (mm) a _p (mm)	0.3-1.2 0.1-0.75	–	0.3-1.2 0.1-0.75	–	–	0.1-1 0.1-0.6

Spindle speed (Vc in m/min)

Material							
Coating grade	Application	Steel	Stainless steel	Cast iron	NF metal and non-metals	High-temperature resistant alloys	Hardened materials
P40 PATM	Roughing Semi-Finish Finish	▽130 190 250 ▽150 225 300 -	-	▽120 170 220 ▽150 200 250 -	-	-	-
P40 PPGO	Roughing Semi-Finish Finish	▽100 150 200 ▽100 150 200 -	-	▽110 130 150 ▽110 130 150 -	-	-	-
K10 PPTi	Roughing Semi-Finish Finish	▽90 140 190 ▽110 160 210	-	▽120 180 240 ▽140 205 270 -	-	-	▽80 120 160 ▽100 140 180
M40 PPST	Roughing Semi-Finish Finish	▽80 140 200 ▽100 150 200	▽80 130 180 ▽100 155 210	-	-	▽30 55 80 ▽40 65 90	-

Expanded application data

Full axial plunge

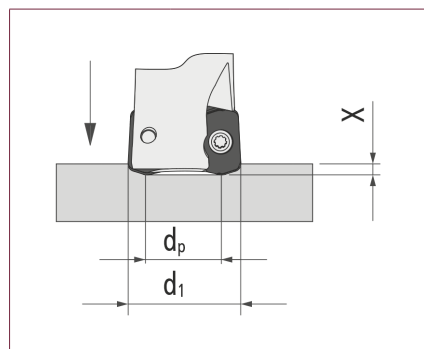

Arbor Ø d1	d _p	X _{max} mm
16	10.78	0.35
20	14.78	0.4
25	19.78	0.45
32	26.78	0.5
35	29.78	0.5
42	36.78	0.55

Full oblique plunge

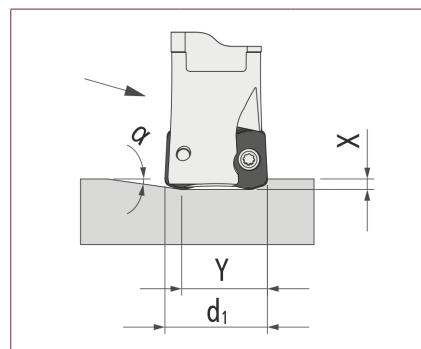

Arbor Ø d1	α°	y mm
16	<2.5	7
20	<1.9	11
25	<1.5	16
32	<1.2	23
35	<1.0	26
42	<0.9	33

Circular milling

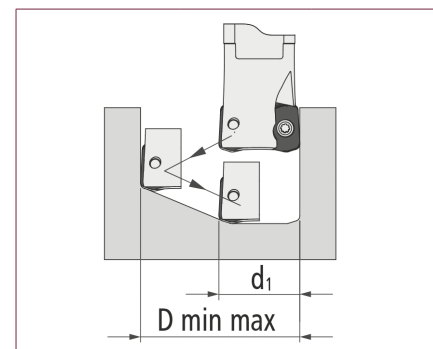

Arbor Ø d1	D _{min} mm	D _{max} mm
16	23	31
20	31	39
25	41	49
32	55	63
35	61	69
42	75	83

Technical information

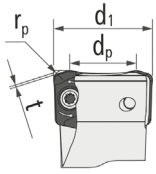

When **CAD/CAM programming** the tool geometry, a milling cutter with theoretical **bull end (r_p)** of 1.4 mm must be used. The unmachined area of **remaining material (t)** is 0.342 mm. The **tool length is measured** on the flat diameter " **d_p** ".

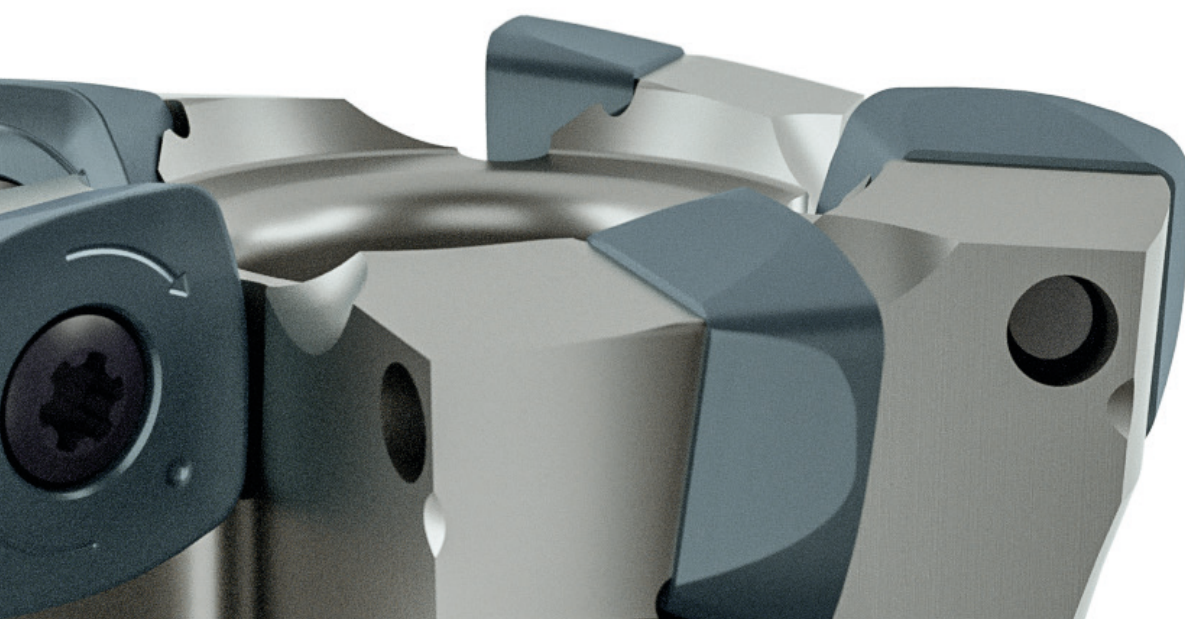

QUADWORX®
high feed cutters

made in Germany
KOKO™

QUADWORX® high feed cutters

High feed design – excellent economic efficiency for universal use



Properties

- universal use in high feed milling
- very high material removal rates and extremely easy cutting for more machine capacity
- 4 cutting flutes / cutting insert for highly economical - use
- torsion eliminated by positioning the cutting inserts over a second flank and 90° contact
- maximum process reliability in interrupted cuts thanks to secure positioning of the inserts
- with wiper edge and large radius, very good surface grades can be achieved even through roughing
- cutter bodies with the designation RF are equally divided and have a hook of 5°

Sizes	Page
M: Ø 22 - 52 mm	188
L: Ø 35 - 80 mm	191
XL: Ø 32 - 100 mm	194

Practical video
QUADWORX® M
in 1.2312 /
40CrMnMoS8-6



Machining types

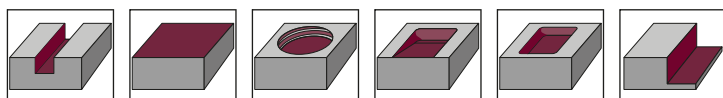

Connection types

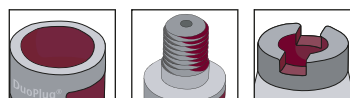

Cutting materials

Size	ISO application						Application data (mm)		Length (mm)	bull end to be programmed (mm)	Quality / coating
	P	M	K	N	S	H	f _z	a _p	l	r _p	
M	▽	▽	▽	–	▽	▽	0.3 - 2.0	0.2 - 1.2	9.0	1.5	P25 PVTi P40 PVTi P40 PVGO M40 PVST K10 PVTi
L	▽	▽	▽	–	▽	▽	0.3 - 2.5	0.25 - 1.5	10.0	2.3	P25 PVTi P40 PVTi P40 PVGO M40 PVST K10 PVTi
XL	▽	▽	▽	–	▽	–	0.3 - 2.0	0.2 - 2.2	13	3.3	P25 PVTi P40 PVTi P40 PVGO M40 PVST K10 PVTi

QUADWORX®

Size M - Ø 22 - 52 mm



Characteristics:



Milling Cutter Bodies	Part no.	d_1	l	r_p^*	l_3	l_2	l_1	d_2	d_3	z
-----------------------	----------	-------	-----	---------	-------	-------	-------	-------	-------	-----

DuoPlug®

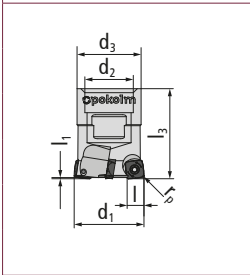

2 22 248 SG	22	9	1.5*	35.5	1.5	–	M 12	18.5	2
3 25 248 SG	25	9	1.5*	40	1.5	–	M 16	23.5	3

Threaded shank end mill body

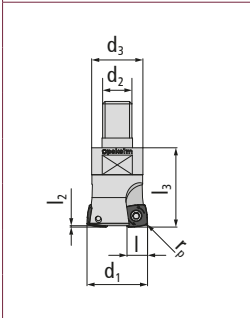

2 22 248	22	9	1.5*	29	1.5	–	M 10	18	2
3 25 248	25	9	1.5*	33	1.5	–	M 12	21	3
4 30 248	30	9	1.5*	42	1.5	–	M 16	29	4
4 32 248	32	9	1.5*	42	1.5	–	M 16	29	4
4 35 248	35	9	1.5*	42	1.5	–	M 16	29	4
5 35 248	35	9	1.5*	42	1.5	–	M 16	29	5
5 42 248	42	9	1.5*	42	1.5	–	M 16	29	5

Shell-type milling cutter body

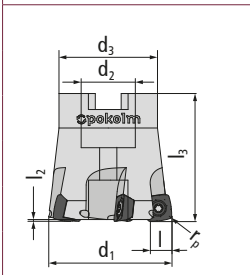

5 42 348	42	9	1.5*	42.5	1.5	–	16	35	5
6 52 348	52	9	1.5*	52.5	1.5	–	22	40	6

The accessories shown here must be used for all sizes!

Accessories

30 500	Torx screw	> Page 197
10 500	Torx wrench	> Page 198
SG25	TORQUE CliX-S grip	> Page 199
TG55	TORQUE CliX-T grip	> Page 199
DM15	Torque adapter 1.5 Nm	> Page 199
T10-R	6-pack bits (Torx)	> Page 200

* Bull end to be programmed

Indexable Inserts	Part no.	DIN designation	Quality	Coating	l	s	r	M
	03 48 842	SDMX 09T307 SN	P40	PVTi	9	3.5	0.7	M 3
	03 48 846	SDMX 09T307 SN	P40	PVGO	9	3.5	0.7	M 3
	03 48 850	SDHX 09T307 SN	P25	PVTi	9	3.5	0.7	M 3
	03 48 852	SDMX 09T307 SN	P25	PVTi	9	3.5	0.7	M 3
	03 48 8035	SDHX 09T307 SN	K10	PVTi	9	3.5	0.7	M 3
	03 48 848	SDMT 09T307 SN	P40	PVGO	9	3.5	0.7	M 3
	03 48 896	SDMT 09T307 SN	M40	PVST	9	3.5	0.7	M 3

Application data (fz / ap)

Material							
Coating grade	Feed rate/ Depth of cut	Steel	Stainless steel	Cast iron	NF metal and non-metals	High-temperature resistant alloys	Hardened materials
P40 PVTi	f _z (mm) a _p (mm)	0.5-2 0.3-1	-	-	-	-	-
P40 PVGO	f _z (mm) a _p (mm)	0.5-2 0.3-1	-	-	-	-	-
P25 PVTi	f _z (mm) a _p (mm)	0.5-2 0.3-1	-	-	-	-	-
K10 PVTi	f _z (mm) a _p (mm)	-	-	0.5-2.2 0.3-1.2	-	-	0.1-1.2 0.1-0.5
M40 PVST	f _z (mm) a _p (mm)	-	0.2-1.2 0.2-0.9	-	-	0.25-0.9 0.2-0.7	-

Spindle speed (Vc in m/min)

Material							
Coating grade	Application	Steel	Stainless steel	Cast iron	NF metal and non-metals	High-temperature resistant alloys	Hardened materials
P40 PVTi	Roughing Semi-Finish Finish	▼100 160 220 ▽100 175 250 -	-	-	-	-	-
P40 PVGO	Roughing Semi-Finish Finish	▼100 150 200 ▽100 150 200 -	-	-	-	-	-
P25 PVTi	Roughing Semi-Finish Finish	▼100 200 300 ▽100 125 150 -	-	-	-	-	-
K10 PVTi	Roughing Semi-Finish Finish	-	-	▼150 175 200 ▽150 175 200 -	-	-	▼100 175 250 ▽35 108 180 -
M40 PVST	Roughing Semi-Finish Finish	-	▼80 130 180 ▽100 155 210 ▽120 185 250	-	-	▼30 55 80 ▽40 65 90 ▽60 90 120	-

Expanded application data

Full axial plunge

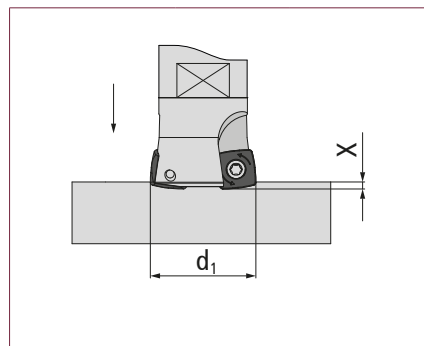

Arbor Ø d1	d_p	X_{max} mm
22	7.1	1.5
25	9.8	1.5
30	14.7	1.5
32	16.7	1.5
35	19.7	1.5
42	26.5	1.5
52	36.5	1.5

Full oblique plunge

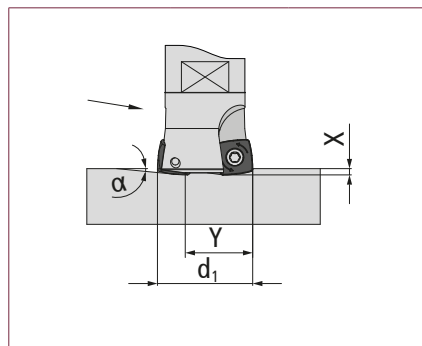

Arbor Ø d1	α°	y mm
22	<13.7	6
25	<9.2	9
30	<5.8	14
32	<4.9	16
35	<4.3	19
42	<3.1	26
52	<2.1	36

Circular milling

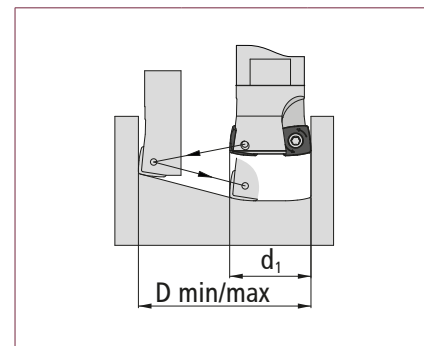

Arbor Ø d1	D_{min} mm	D_{max} mm
22	28.5	44
25	34.5	50
30	44.5	60
32	48.5	64
35	54.5	70
42	68.5	84
52	88.5	104

Technical information

When **CAD/CAM programming** the tool geometry, a milling cutter with theoretical **bull end (r_p) of 1.5 mm** must be used. The unmachined area of **remaining material (t)** is 0.65 mm. The **tool length is measured** on the flat diameter " d_p ".

QUADWORX®

Size L - Ø 35 - 80 mm

Characteristics:

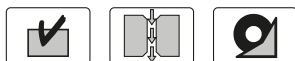

Milling Cutter Bodies	Part no.	d_1	l	r_p^*	l_3	l_2	l_1	d_2	d_3	z
-----------------------	----------	-------	-----	---------	-------	-------	-------	-------	-------	-----

Threaded shank end mill body

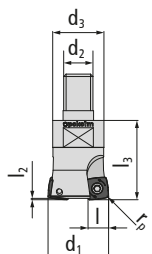

3 35 249	35	10	2.3*	42	2.5	–	M 16	29	3	
Accessories	40 505 K	Torx screw						> Page 197		
	15 500	Torx wrench						> Page 198		
4 42 249	42	10	2.3*	42	2.5	–	M 16	29	4	
Accessories	40 505 K	Torx screw						> Page 197		
	15 500	Torx wrench						> Page 198		

Shell-type milling cutter body

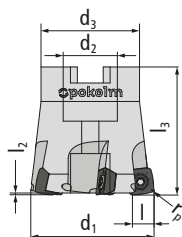

4 42 349	42	10	2.3*	42	2.5	–	16	35	4	
Accessories	40 505 P	Torx screw						> Page 197		
	15 500 P	Torx wrench (Torx Plus)						> Page 198		
5 52 349	52	10	2.3*	52	2.5	–	22	40	5	
Accessories	40 505 P	Torx screw						> Page 197		
	15 500 P	Torx wrench (Torx Plus)						> Page 198		
7 66 349	66	10	2.3*	52	2.5	–	27	48	7	
Accessories	40 505 P	Torx screw						> Page 197		
	15 500 P	Torx wrench (Torx Plus)						> Page 198		
8 80 349	80	10	2.3*	52	2.5	–	27	60	8	
Accessories	40 505 P	Torx screw						> Page 197		
	15 500 P	Torx wrench (Torx Plus)						> Page 198		

The accessories shown here must be used for all sizes

Accessories

SG25	TORQUE CliX-S grip	> Page 199
TG55	TORQUE CliX-T grip	> Page 199
DM38	Torque adapter 3.8 Nm	> Page 199
TP15-R	6-pack bits (Torx Plus)	> Page 200

* Bull end to be programmed

QUADWORX® HIGH FEED CUTTERS (HSC)

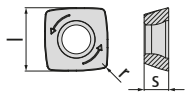
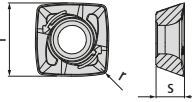
Indexable Inserts	Part no.	DIN designation	Quality	Coating	l	s	r	M
	04 49 842	SDMX 100510 SN	P40	PVTi	10	5	1	M 4
	04 49 846	SDMX 100510 SN	P40	PVGO	10	5	1	M 4
	04 49 852	SDMX 100510 SN	P25	PVTi	10	5	1	M 4
	04 49 860	SDHX 100510 SN	K10	PVTi	10	5	1	M 4
	04 49 896	SDMT 100510 SN	M40	PVST	10	5	1	M 4

Application data (fz / ap)

Material							
Coating grade	Feed rate/ Depth of cut	Steel	Stainless steel	Cast iron	NF metal and non-metals	High-temperature resistant alloys	Hardened materials
P40 PVTi	f _z (mm) a _p (mm)	0.5-2.5 0.3-1.5	–	–	–	–	–
P40 PVGO	f _z (mm) a _p (mm)	0.5-2.5 0.3-1.5	–	–	–	–	–
P25 PVTi	f _z (mm) a _p (mm)	0.5-2.5 0.3-1.5	–	–	–	–	–
K10 PVTi	fz (mm) ap (mm)	–	–	0.5-2.5 0.3-1.7	–	–	0.3-1.5 0.3-0.8
M40 PVST	f _z (mm) a _p (mm)	–	0.3-1.5 0.25-1.3	–	–	0.3-1 0.25-0.9	–

Spindle speed (Vc in m/min)

Material							
Coating grade	Application	Steel	Stainless steel	Cast iron	NF metal and non-metals	High-temperature resistant alloys	Hardened materials
P40 PVTi	Roughing Semi-Finish Finish	▼100 160 220 ▽100 175 250 –	–	–	–	–	–
P40 PVGO	Roughing Semi-Finish Finish	▼100 150 200 ▽100 150 200 –	–	–	–	–	–
P25 PVTi	Roughing Semi-Finish Finish	▼100 200 300 ▽100 125 150 –	–	–	–	–	–
K10 PVTi	Roughing Semi-Finish Finish	–	–	▼150 175 200 ▽150 175 200 –	–	–	▼100 175 250 ▽120 150 180
M40 PVST	Roughing Semi-Finish Finish	–	▼80 130 180 ▼100 155 210 ▽120 185 250	–	–	▼30 55 80 ▼40 65 90 ▽60 90 120	–

Expanded application data

Full axial plunge			Full oblique plunge			Circular milling		
Arbor \varnothing d1	d_p	X_{max} mm	Arbor \varnothing d1	α°	y mm	Arbor \varnothing d1	D_{min} mm	D_{max} mm
35	17.7	2.5	35	<8.3	17	35	52	70
42	24.7	2.5	42	<5.9	24	42	66	84
52	34.7	2.5	52	<4.2	34	52	86	104
66	48.7	2.5	66	<2.9	48	66	114	132
80	62.7	2.5	80	<2.3	62	80	142	160

Technical information

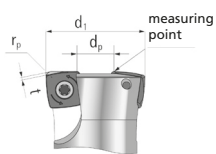

When **CAD/CAM programming** the tool geometry, a milling cutter with theoretical **bull end (r_p) of 2.3 mm** must be used. The unmachined area of **remaining material (t)** is 0.83 mm. The **tool length is measured** on the flat diameter " d_p ".

QUADWORX®

Size XL - Ø 32 - 100 mm



Milling Cutter Bodies	Part no.	d_1	l	r_p^*	l_3	l_2	l_1	d_2	d_3	z
-----------------------	----------	-------	-----	---------	-------	-------	-------	-------	-------	-----

Threaded shank end mill body

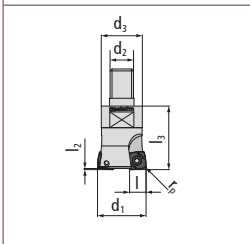

2 32 251	32	13	3.3*	42	1.5	-	M 16	29	2
3 35 251	35	13	3.3*	42	1.5	-	M 16	29	3

Shell-type milling cutter body

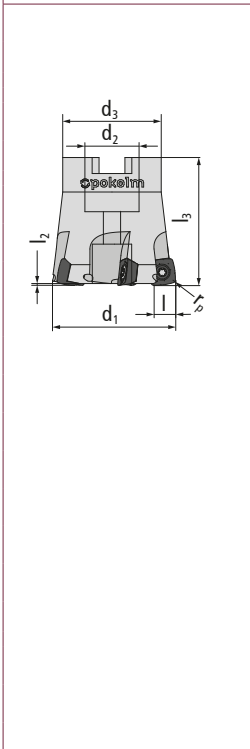

4 40 351	40	13	3.3*	42.5	2.5	-	16	35	4	
Accessories	GWSTPS8ISK		Setscrew with hexagon socket				> Page 198			
4 42 351	42	13	3.3*	42.5	2.5	-	16	35	4	
Accessories	GWSTPS8ISK		Setscrew with hexagon socket				> Page 198			
4 50 351	50	13	3.3*	50	2.5	-	22	40	4	
5 50 351	50	13	3.3*	50	2.5	-	22	40	5	
5 50 351 RF	50	13	3.3*	50	2.5	-	22	40	5	
5 52 351	52	13	3.3*	50	2.5	-	22	48	5	
5 52 351 RF	52	13	3.3*	50	2.5	-	22	48	5	
6 63 351	63	13	3.3*	53	2.5	-	27	48	6	
6 63 351 RF	63	13	3.3*	53	2.5	-	27	48	6	
6 66 351	66	13	3.3*	53	2.5	-	27	48	6	
6 66 351 RF	66	13	3.3*	53	2.5	-	27	48	6	
6 80 351	80	13	3.3*	53	2.5	-	27	60	6	
7 100 351	100	13	3.3*	53	2.5	-	32	70	7	
Accessories	M16X35		Cheese-head screw hexagon socket low head				> Page 197			
8 80 351	80	13	3.3*	53	2.5	-	27	60	8	
9 100 351	100	13	3.3*	53	2.5	-	32	70	9	
Accessories	M16X35		Cheese-head screw hexagon socket low head				> Page 197			

The accessories shown here must be used for all sizes

Accessories	Part no.	Description	Page
	40 505 K	Torx screw	> Page 197
	15 500 P	Torx wrench (Torx Plus)	> Page 198
	SG25	TORQUE CliX-S grip	> Page 199
	TG55	TORQUE CliX-T grip	> Page 199
	DM38	Torque adapter 3.8 Nm	> Page 199
	TP15-R	6-pack bits (Torx Plus)	> Page 200

Indexable Inserts	Part no.	DIN designation	Quality	Coating	l	s	r	M
	05 51 852 HF	SDMW 135020 SN	P25	PVTi	13	5	2	M 4
	05 51 860 HF	SDHX 135020 SN	K10	PVTi	13	5	2	M 4
	05 51 862 HF	SDMW 135020 SN	K10	PVTi	13	5	2	M 4
	05 51 8242 HF	SDMW 135020 SN	P40	PATM	13	5	2	M 4
	05 51 848 HF	SDMT 135020 SN	P40	PVGO	13	5	2	M 4
	05 51 858 HF	SDMT 135020 SN	P25	PVGO	13	5	2	M 4
	05 51 868 HF	SDMT 135020 SN	K10	PVGO	13	5	2	M 4
	05 51 896 HF	SDMT 135020 EN	M40	PVST	13	5	2	M 4

Application data (fz / ap)

Material							
Coating grade	Feed rate/ Depth of cut	Steel	Stainless steel	Cast iron	NF metal and non-metals	High-temperature resistant alloys	Hardened materials
P25 PVTi	f _z (mm) a _p (mm)	0.6-2.8 0.5-2	–	0.6-2.5 0.6-2.2	–	–	–
K10 PVTi	f _z (mm) a _p (mm)	0.6-2.8 0.5-2	–	0.6-2.5 0.6-2.2	–	–	–
P40 PVGO	f _z (mm) a _p (mm)	0.5-2.5 0.4-2	–	0.6-2.5 0.5-2.2	–	–	–
P40 PATM	f _z (mm) a _p (mm)	0.6-2.8 0.5-2	–	0.6-2.5 0.6-2.2	–	–	–
P25 PVGO	f _z (mm) a _p (mm)	0.5-2.5 0.4-2	–	0.6-2.5 0.5-2.2	–	–	–
K10 PVGO	f _z (mm) a _p (mm)	0.5-2.5 0.4-2	–	0.6-2.5 0.5-2.2	–	–	–
M40 PVST	f _z (mm) a _p (mm)	–	0.3-1.7 0.5-1.5	–	–	0.3-1.2 0.4-1.5	–

Technical information

When **CAD/CAM programming** the tool geometry, a milling cutter with theoretical **bull end (r_p) of 3.3 mm** must be used. The unmachined area of **remaining material (t)** is 0.86 mm. The **tool length is measured** on the flat diameter "**d_p**".

Spindle speed (Vc in m/min)

Material							
Coating grade	Application	Steel	Stainless steel	Cast iron	NF metal and non-metals	High-temperature resistant alloys	Hardened materials
P25 PVTi	Roughing Semi-Finish Finish	▽100 200 300 ▽100 125 150 –	–	▽130 155 180 ▽100 135 170 –	–	–	–
K10 PVTi	Roughing Semi-Finish Finish	▽130 170 210 ▽150 185 220 –	–	▽150 175 200 ▽150 175 200 –	–	–	–
P40 PVGO	Roughing Semi-Finish Finish	▽100 150 200 ▽100 150 200 –	–	▽110 130 150 ▽110 130 150 –	–	–	–
P40 PATM	Roughing Semi-Finish Finish	▽130 190 250 ▽150 225 300 –	–	▽120 170 220 ▽150 200 250 –	–	–	–
P25 PVGO	Roughing Semi-Finish Finish	▽110 165 220 ▽120 185 250 –	–	▽120 145 170 ▽130 150 170 –	–	–	–
K10 PVGO	Roughing Semi-Finish Finish	▽130 170 210 ▽150 185 220 –	–	▽110 155 200 ▽150 175 200 –	–	–	–
M40 PVST	Roughing Semi-Finish Finish	–	▽80 130 180 ▽100 155 210 –	–	–	▽30 55 80 ▽40 65 90 –	–

Expanded application data

Full axial plunge		
Arbor Ø d1	d _p	X _{max} mm
32	11.8	1.5
35	14.8	1.5
40	19.8	2.5
42	21.8	2.5
50	29.8	2.5
52	31.8	2.5
63	42.8	2.5
66	45.8	2.5
80	59.8	2.5
100	79.8	2.5





Full oblique plunge		
Arbor Ø d1	α°	y mm
32	<9	8.8
35	<7.0	11.8
40	<6.5	16.8
42	<5.8	18.8
50	<4.1	26.8
52	<3.7	28.8
63	<2.6	39.8
66	<2.4	42.8
80	<1.8	56.8
100	<1.2	72.8

Circular milling		
Arbor Ø d1	D _{min} mm	D _{max} mm
32	40.8	62
35	46.8	68
40	56.8	78
42	60.8	82
50	76.8	98
52	80.8	102
63	102.8	124
66	108.8	130
80	136.8	158
100	176.8	198

Pokolm original accessories

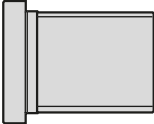
Accessories	Part no.	Designation	Dimensions			
Torx®screws Torx®screws						
	18 500	Torx screw M 1.8 L 3.7 T 6 0.28 Nm	M 1,8	L 3,7	T 6	0,28 Nm
	21 500	Torx screw M 2.0 L 4 T 6 0.43 Nm	M 2,0	L 4	T 6	0,43 Nm
	21 500 P	Torx screw M 2.0 L 4 T 6 Plus 0.5 Nm	M 2,0	L 4	T 6 Plus	0,5 Nm
	22 500 P	Torx screw M 2,2 L 5,2 T 7 Plus 0,65 Nm	M 2,2	L 5,2	T 7 Plus	0,65 Nm
	25 500	Torx screw M 2.5 L 5.0 T 7 0.9 Nm	M 2,5	L 5,0	T 7	0,9 Nm
	25 550	Torx screw M 2.5 L 5.4 T 8 0.9 Nm	M 2,5	L 5,4	T 8	0,9 Nm
	25 500 K	Torx screw M 2.5 L 4.5 T 7 0.75 Nm	M 2,5	L 4,5	T 7	0,75 Nm
	25 500 K-1	Torx screw M 2,5 L 4,2 T 7 0,9 Nm	M 2,5	L 4,2	T 7	0,9 Nm
	25 505 KP	Screw for Slotworx M Ø16;20;25 M 2.5 L 5.3 T 8 Plus 1.0 Nm	M 2,5	L 5,3	T 8 Plus	1,0 Nm
	25 505 P	Screw for Slotworx M Ø 32; 42; 52 M 2.5 L 7.3 T 8 Plus 1.0 Nm	M 2,5	L 7,3	T 8 Plus	1,0 Nm
	30 500	Torx screw M 3,0 L 7,0 T 10 1,5 Nm	M 3,0	L 7,0	T 10	1,5 Nm
	35 500	Torx screw M 3.5 L 11 T 15 2,4 Nm	M 3,5	L 7,5	T 15	2,4 Nm
	35 500 L	Torx screw M 3.5 L 11 T 15 2,4 Nm	M 3,5	L 11	T 15	2,4 Nm
	35 505 P	Torx screw M 3,5 L 9 T 10 Plus 2,4 Nm	M 3,5	L 9	T 10 Plus	2,4 Nm
	40 505 K	Torx screw M 4,0 L 9,35 T 15 Plus 3,6 Nm	M 4,0	L 9,35	T 15 Plus	3,6 Nm
	40 505 P	Torx screw M 4,0 L 10,58 T 15 Plus 3,6 Nm	M 4,0	L 10,58	T 15 Plus	3,6 Nm
45 500	Torx screw M 4,5 L 10,0 T 20 4,3 Nm	M 4,5	L 10,0	T 20	4,3 Nm	
45 500 L	Torx screw M 4,5 L 14,5 T 20 4,3 Nm	M 4,5	L 14,5	T 20	4,3 Nm	
Torx®screws Torx®screws for ball nose insert						
	25 505	Torx screw for ball nose insert M 2.5 L 6.36 T 8 Plus 1.0 Nm	M 2,5	L 6,36	T 8 Plus	1,0 Nm
	30 505	Torx screw for ball nose insert M 3.0 L 7.25 T 9 Plus 1.5 Nm	M 3,0	L 7,25	T 9 Plus	1,5 Nm
	40 505	Torx screw M 4,0 L 10,58 T 15 3,6 Nm	M 4,0	L 10,58	T 15	3,6 Nm
Torx®screws Locating screws						
	30 530	Locating screw M 3.0 L 6.9 T 8 1.5 Nm	M 3,0	L 5,35	T 8	1,5 Nm
	30 522	Locating screw M 3.0 L 6.9 T 8 1.5 Nm	M 3,0	L 6,9	T 8	1,5 Nm
	35 520	Locating screw M 3.5 L 7.6 T 10 2.4 Nm	M 3,5	L 7,6	T 10	2,4 Nm
	35 530	Locating screw M 3.5 L 7.6 T 10 2.4 Nm	M 3,5	L 7,6	T 10	2,4 Nm
	40 520	Locating screw M 4.0 L 10.2 T 15 3.6 Nm	M 4,0	L 10,2	T 15	3,6 Nm
	50 520	Locating screw M 5.0 L 13.5 T 20 5.5 Nm	M 5,0	L 13,5	T 20	5,5 Nm
	50 530	Locating screw M 5.0 L 13.5 T 20 5.5 Nm	M 5,0	L 9,2	T 20	5,5 Nm
Torx®screws Locking screws						
	35 510	Locking screws M 3.5 T 15	M 3,5	–	T 15	–
	35 511	Locking screws M 3.5 T 10	M 3,5	–	T 10	–
Cheese-head screws with hexagon socket for shell-type and threaded adapters						
	M16X35	Zylinderschraube Innensechskant niedriger Kopf	M 16	L 35	DIN 7984	–
	M20X35	Zylinderschraube Innensechskant niedriger Kopf	M 20	L 35	DIN 7984	–

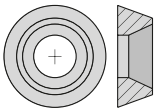
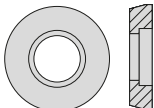
Pokolm original accessories

Accessories	Part no.	Designation	Dimensions			
Other screws and washers threaded bush						
	35 500 I	Threaded bush interior M3.5 exterior M5x0.5 hexa. 3.5	interior M3.5	exterior M5x0.5	hexa. size 3.5	–
	45 500 I	Threaded bush interior M4.5 exterior M6x0.75 hexa. 4.5	interior M4.5	exterior M6x0.75	hexa. size 4.5	–
Other screws and washers power screw						
	GWSTPS8ISK	Setscrew with hexagon socket M8x1.25 M8x0.75 hexa. 4	M8x1.25	M8x0.75	hexa. size 2.5	–
	GWSTPS10ISK	Setscrew with hexagon socket M10x1.5 M10x1 hexa. 5	M10x1.5	M10x1	hexa. size 2.5	–
Other screws and washers locking washers						
	10 510	Locking washer Ø 11 for M 4.5	Diameter 11	for M 4.5	–	–
Other screws and washers shim						
	09 511	Shim for RDHX 12T3 Ø 10	Diameter 10	–	–	–
	10 511	Shim for RDHX 1604 Ø 14	Diameter 14	–	–	–
Wrenches Torx wrench						
	06 500	Torx wrench T 6	T 6	–	–	–
	06 500 P	Torx wrench (Torx Plus) T 6 IP	T 6 IP	–	–	–
	07 500	Torx wrench T 7	T 7	–	–	–
	07 500 P	Torx wrench (Torx-Plus) T 7 IP	T 7 IP	–	–	–
	08 500	Torx wrench T 8	T 8	–	–	–
	08 500 P	Torx wrench (Torx Plus) T 8 IP	T 8 IP	–	–	–
	09 500	Torx wrench T 9	T 9	–	–	–
	10 500	Torx wrench T 10	T 10	–	–	–
	10 500 P	Torx wrench (Torx Plus) T 10 IP	T 10 IP	–	–	–
	15 500	Torx wrench T 15	T 15	–	–	–
	15 500 P	Torx wrench (Torx Plus) T 15 IP	T 15 IP	–	–	–
	20 500	Torx wrench T 20	T 20	–	–	–



Accessories	Part no.	Designation	Dimensions			
-------------	----------	-------------	------------	--	--	--

Wrenches Allen key						
	ALLEN 3.5 W	Allen wrench size 3.5 angle	Angle	-	-	-
	ALLEN 4.5 W	Allen wrench size 4.5 angle	Angle	-	-	-

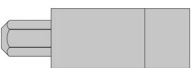
Torque screwdrivers and accessories Grips						
	SG25	TORQUE CLiX S-grip	-	-	-	-
	TG55	TORQUE CLiX T-grip	-	-	-	-

Torque screwdriver and accessories Torque adapters						
	DM04	Torque adapter 0.4 Nm	-	-	0.4 Nm	-
	DM06	Torque adapter 0.6 Nm	-	-	0.6 Nm	-
	DM09	Torque adapter 0.9 Nm	-	-	0.9 Nm	-
	DM10	Torque adapter 1.0 Nm	-	-	1.0 Nm	-
	DM15	Torque adapter 1.5 Nm	-	-	1.5 Nm	-
	DM22	Torque adapter 2.2 Nm	-	-	2.2 Nm	-
	DM25	Torque adapter 2.5 Nm	-	-	2.5 Nm	-
	DM38	Torque adapter 3.8 Nm	-	-	3.8 Nm	-
	DM55	Torque adapter 5.5 Nm	-	-	5.5 Nm	-

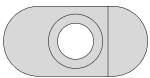
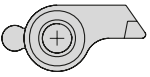
Pokolm original accessories

Accessories	Part no.	Designation	Dimensions			
Torque screwdriver and accessories Torx bits						
	T06-R	6-pack bits (Torx)	T06	–	–	–
	TP06-R	6-pack bits (Torx Plus)	T06 IP	–	–	–
	T07-R	6-pack bits (Torx)	T07	–	–	–
	TP07-R	6-pack bits (Torx Plus)	T07 IP	–	–	–
	T08-R	6-pack bits (Torx)	T08	–	–	–
	TP08-R	6-pack bits (Torx Plus)	T08 IP	–	–	–
	T09-R	6-pack bits (Torx)	T09	–	–	–
	TP09-R	6-pack bits (Torx Plus)	T09 IP	–	–	–
	T10-R	6-pack bits (Torx)	T10	–	–	–
	T15-R	6-pack bits (Torx)	T15	–	–	–
	T20-R	6-pack bits (Torx)	T20	–	–	–
	Clamping claws					
	12 510	Clamping claws for Trigaworx® S for M 2.5	for M 2.5	–	–	–
Clamping finger						
	10 514	Clamp finger for CBN with screw M 4.0 T 15	–	T 15	–	–
Cleaning / copper paste						
	Z 00043	HTC ceramic paste WS 600 005 5 gr tube	5 gr tube	–	–	–



High-frequency spindles

Modern spindle systems for effective milling performance.

Many milling machines – both newer machines and older models – have a relatively low maximum speed. A low maximum speed, of course, delivers advantages in roughing, but is the biggest brake on achieving effective feed rates. Low speeds likewise greatly restrict the advantages of modern CNC applications. The consequence are significantly longer machining times, and a loss of profitable capacity.

Pokolm offers impressive solutions for just this problem: modern spindle systems for effective milling results.

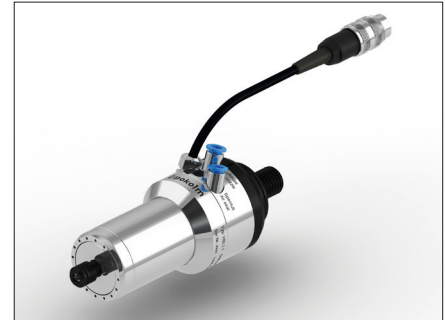

Better surfaces and significant time savings.

The advantages are impressive: higher speeds and utilizing the maximum feed rate – even for the smallest cutters. For improved surfaces and significant reduction in eroding work. This results in significantly shorter machining times and full utilization of the advantages of CNC.

Get the maximum speed from your machines with Pokolm spindles and save time as a result.

Ask about our spindle service, including:

- Replacement parts
- Repairs
- Inspection
- Maintenance
- Swivel devices
- CNC machine connection

Get in touch with us!

Shrinking technology

First shrink, then mill

More and more users are switching to shrinking technology, thanks to the advantages it offers over common clamping methods. The biggest of these is extremely good concentricity, which guarantees the highest precision with significantly longer tool lives.

In addition, shrinking technology creates an optimal frictional connection between the tool and arbor, ensuring high torque transmission. And suitability for maximum speed is the best prerequisite for achieving an ideal surface grade thereby avoiding expensive ultrafine machining processes.

In comparison to traditional tool arbors, shrink fit arbors have a slimmer design, making it possible to use even the smallest tools at the greatest depths, something impossible with a collet chuck.

Pokolm offers a comprehensive range of shrinking technology products: a high-quality, well-engineered induction shrinking device, shrink fit arbors for all common machine connections, and the patented Pokolm DuoPlug® connection system.

More information on Pokolm DuoPlug® is available on pages 18 and 19.

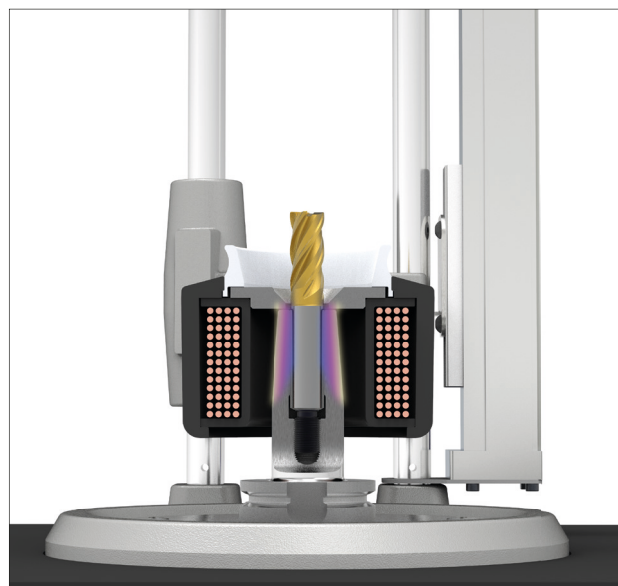

The latest addition to our portfolio: Gravfix

In many manufacturing companies, demanding tasks are part of day-to-day operations. Solutions are needed that ensure efficient production. In certain process steps, more and more industries are adopting reliable marking methods for the marking of electrodes, tools, workpieces and series components as well as entire component assemblies.

Gravfix is a dot peen marker that has been developed for a wide range of applications. This versatile tool performs precise engravings at high speed and is suitable for various different materials and marking tasks.

Discover even more advantages
of Gravfix: pokolm.com/en/products/gravfix.



www.pokolm.com/gravfix



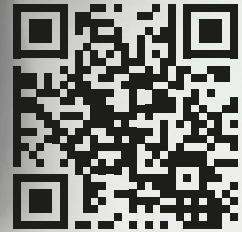

www.qrco.de/spotfix-en

Spotfix

Boost productivity

Spotfix allows lubricant to be applied precisely and accurately to core holes. In the production process, the noncontact lubrication system enables threads to be milled, drilled, or formed automatically. When threads are milled or drilled, an automated process increases safety and reduces costs. However, the lubricating effect of the machine's own cooling lubricant is often insufficient for drilling threads in high-alloy steels, for example. If thread milling is not an option, the program must be stopped to manually lubricate the core hole. This is where Spotfix supports automation. Clamped into a tool holder, the lubrication system applies lubricant precisely to the core hole without interrupting the ongoing manufacturing process.

Learn more about Spotfix at www.qrco.de/spotfix-en.



Material overview with comparison table

M No.	DIN	European standard	France AFNOR	Great Britain BS	Japan JIS	Italy UNI	Sweden SS	Spain U.N.E./I.H.A	USA AISI/SAE
Steel									
Unalloyed steel/structural steel									
1.0037	St37-2	S235JR	E34-2	37/23 HR	SN 400 B	Fe 360 B FU	1311	AE 235 B	1015
1.0044	St44-2	S275JR	E28-2	43/25 HR	SN 400 B	Fe 430 B FN	1412	AE 275 B	1020
1.0050	St50-2G	E295	A50-2	4360	SS 490	Fe 490	1550/2172	A 490	–
1.0070	St70-2G	E360	A70-2	4360	–	Fe 690	1655	A 690	–
1.0570	St52-3	S355J2G3	E36-3	50/35 HR	SM490 A;B;C;YA;YB	Fe 510/Fe52B FN/Fe52 CFN	2132/2134	AE 355 D	1024
1.1141	Ck15	C15E	XC 18	080 M 15	S15C	C16	1370	C15K	1015 / 1017
1.1191	Ck45	C45E	XC 45	080 M 46	S45C	C45	1672	C45E	1042 / 1045
1.1730	C45W	C45U	Y3 42 / Y3 48	EN 43 B	–	–	1672	F.114	1045
1.7131	16MnCr5	16MnCr5	16 MC 5	527 M 17	–	16MnCr5	2173/2511	F.1516	5115 / 5117
Steel									
Normal tool steels/cast steel									
1.2067	100Cr6	102Cr6	Y100C6	BL 3	SUJ 2	–	–	100Cr6	L3
1.2162	21MnCr5	21MnCr5	–	–	–	–	–	–	–
1.2307	29CrMoV9	29CrMoV9	–	–	–	–	–	–	–
1.2311	–	35CrMo 8	–	–	–	35CrMo8KU	–	F.5263	P20
1.2312	40CrMn MoS8-6	–	–	–	–	–	–	X210CrW12	P20+S
1.2323	48Cr MoV6-7	–	–	–	–	–	–	–	–
1.2341	6CrMo15-5	5CrMo16	–	–	–	–	–	–	P4
1.2343	–	–	Z38CDV5	BH 11	SKD 6	X37Cr MoV51KU	X37CrMo V5-1	X37Cr MoV5-1	H11
1.2344	–	X40 CrMoV5-1	Z40CDV5	BH 13	SKD 61	X40CrMo V511KU	2242	X40Cr MoV5-1	H13
1.2842	90MnCrV8	90MnCrV8	90MV 8	BO 2	–	90 MnCrV 8 KU	–	F.5229	O2
Steel									
Tool steels, difficult to machine/cast steel, difficult to machine									
1.2080	X210Cr12	X210Cr12	Z200C12	BD 3	SKD 1	–	X210Cr12	X210Cr12	D3
1.2363	X100 CrMoV5	X100CrMoV5	Z100CDV5	BA 2	SKD 12	X205 Cr12KU	2260	X100CrMoV5	A2
1.2369	81MoCr V42-16	–	–	–	–	X100Cr MoV5 1KU	–	–	613
1.2379	X153 CrMoV12	X153 CrMoV12	Z 160 CDV 12	BD 2	SKD10/ SKD11	X155CrV Mo121KU	2310	X153 CrMoV12	D2
1.2567	30WCr V17-2	X30WCrV53	–	–	SKD 4	–	–	–	–
1.2708	54NiCr MoS 6	–	–	–	–	–	–	–	–
1.2713	55Ni CrMoV6	55 Ni CrMoV 7	–	–	(SKT4)	–	–	F.520.5	L6

M No.	DIN	European standard	France AFNOR	Great Britain BS	Japan JIS	Italy UNI	Sweden SS	Spain U.N.E./I.H.A	USA AISI/SAE
-------	-----	-------------------	--------------	------------------	-----------	-----------	-----------	--------------------	--------------

Steel
Tool steels, difficult to machine

1.2738	40CrMnNi Mo8-6-4	40CrMnNi Mo8-6-4	-	-	-	-	-	-	-
1.2767	45NiCrMo16	45NiCrMo16	-	-	SKT 6	40NiCrMo V16KU	-	-	-
1.6358	XNiCo Mo18-9-5	-	-	-	-	-	-	-	-

High-temperature resistant alloys
Heat-resistant alloys

1.3401	X120Mn12	-	Z120M12	BW 10	SCMnH 1	G-X120Mn12	2183	F.8251	-
1.4865	GX40NiCr Si38-19	GX40NiCr Si38-19	GX40NiCr Si38-19	3330 C 11 / 331 C 40	SCH 15	GX40NiCr Si38-19	GX40NiCr Si38-19	GX40NiCr Si38-19	-
2.4375	NiCu30Al (Monel K-500)	-	(NU30AT)	NA 18	-	-	-	-	Monel K-500
2.4610	NiMo16Cr16Ti (Almenit 4610)	-	-	NA 45	-	-	-	-	Hastelloy C-4
2.4619	NiCr22Mo7Cu (Coralloy 4619)	-	-	-	-	-	-	-	Hastelloy G-3
2.4631	NiCr20TiAl (Nimonic 80A)	Ni-P95-HAT (AECMA)	NC 20 TA	(2HR201; HR401,601)	NCF 80 A	-	-	-	Nimonic 80 A; HEV 5
2.4636	NiCo15Cr15Mo AlTi (Dux 4636)	-	-	HR 4	-	-	-	-	Nimonic 115
2.4648	EL-NiCr19Nb (FoxNibas 70/20)	-	-	-	-	-	-	-	-
2.4668	NiCr19NbMo (Inconel 718)	NiCr19Fe19 Nb5Mo3	NC19FeNb	NiCr19Fe19 Nb5Mo3	NCF 718	NiCr19Fe19 Nb5Mo3	NiCr19Fe19 Nb5Mo3	NiCr19Fe19 Nb5Mo3	Inconel 718 XEV-I
2.4856	NiCr22Mo9Nb (Inconel 625)	NiCr22MO9Nb	NC22FeDNb	NA 43/Na 21	NCF 625	NiCr22M-09Nb	NiCr22MO9Nb	NiCr22MO9Nb	Inconel 625

High-temperature resistant alloys
Titanium alloys

-	Ti99.5 HB 30-200	-	-	-	-	-	-	-	-
-	Ti99.6 HB 30-170	-	-	-	-	-	-	-	-
-	Ti99.7 HB 30-150	-	-	-	-	-	-	-	-
-	Ti99.8 HB 30-120	-	-	-	-	-	-	-	-
-	TiAl6V4ELI	-	-	TA11	-	-	-	-	AMS R56401
-	TiAl5Sn2.5	-	T-A5E	TA14/17	-	-	-	-	AMS 54520
3.7025	Ti 1	-	-	2 TA 1	-	-	-	-	AMS R50250
3.7124	TiCu2	-	-	2 TA21-24	-	-	-	-	-
3.7145	TiAl6Sn2 Zr4Mo2Si	-	-	-	-	-	-	-	AMS R54620
3.7165	TiAl6V4	-	T-A6V	TA10-13 / TA28	-	-	-	-	AMS R56400
3.7175	TiAl6V6Sn2	-	-	-	-	-	-	-	-
3.7184	TiAl4Mo4Sn2	-	-	-	-	-	-	-	-
3.7185	TiAl4Mo4Sn2	-	-	TA 45-51; TA57	-	-	-	-	-
3.7225	Ti 1 Pd	-	-	TP1	-	-	-	-	AMS 52250

Material overview with comparison table

M No.	DIN	European standard	France AFNOR	Great Britain BS	Japan JIS	Italy UNI	Sweden SS	Spain U.N.E./I.H.A	USA AISI/SAE
Stainless steel									
All types									
1.2316	X36CrMo17	X38CrMo16	Z38CD16-01	X38CrMo16	–	X38CrMo16	–	F.5267	–
1.2367	X38CrMo V5-3	X38CrMoV5-3	Z38CDV5-3	X38CrMoV5-3	–	X38CrMoV5-3	X38CrMoV5-3	X38CrMoV5-3	–
1.3543	X102Cr Mo17	X108CrMo17	Z100CD17	X108CrMo17	SUS 440C	X105CrMo17	X108CrMo17	F.3425	440 C
1.4059	GX22CrNi17	–	Z20CN 17.2M	ANC 2	–	–	–	–	–
1.4122	GX35CrMo17	X39CrMo17-1	Z38CD 16.1CI	X39CrMo17-1	–	X39CrMo17-1	X39CrMo17-1	X39CrMo17-1	–
1.4301	X5CrNi18-10	X5CrNi18-10	Z6CN18.09	304 S 15	SUS 304	X5CrNi1810	2332	F.3504	304
1.4305	X12Cr NiS18-8	X8CrNiS18-9	Z8CNF18-09	303 S 31	SUS 303	X10CrNiS18-9	2346	F.310.C	303
1.4340	GX40Cr Ni27-4	–	–	–	–	G X 35 CrNi 28 05	–	–	–
1.4401	X5CrNiMo 12-17-2	X5CrNiMo 12-17-2	Z7CND 11-17-02	316 S 33	SUS 316	X5CrNiMo 17 12	2347	F.3534	316
1.4462	X2CrNiMoN 5-22-3	X2CrNiMoN 5-22-3	Z2CND 06-22-03	318 S 13	SUS 329J3L	X2CrNiMoN 5-22-3	2377	X2CrNiMoN 5-22-3	S31803/ S32205
1.4541	X10CrNi-Ti18-9	X6CrNiTi18-10	Z6CNT 18-10	321 S 31	SUS 321	X6CrNiTi18-10	2337	F.3523	321
1.4551	X10CrNi 1 8-9	X5CrNiNb 20 10 KE	Z6CNNb 20-10	–	SUS Y 374	–	–	–	–
1.4571	X10CrNiMo Ti18-10	X6CrNiMo Ti17-12-2	Z6 CNDT 17-12	320 S 31	SUS 316Ti	X6CrNiMo Ti17-12	2350	F.3535	316Ti
1.4712	X10CrSi6	–	–	–	–	–	–	–	–
1.4742	X10CrAl18	X10CrSi18	Z10CAS18	430 S 15	SUS 430	X8Cr17	–	F.3113	430
Cast iron									
Gray cast iron									
0.6010	GG10	EN-GJL-100	Ft10D	GRADE100	FC 10	G10	0110-00	FG 10	NO 20 B
0.6020	GG20	EN-GJL-200	Ft20D	GRADE200	FC 20	G20	0120-00	FG 20	No 30 B
0.6030	GG30	EN-GJL-300	Ft30D	GRADE300	FC 30	G30	0130-00	FG 30	No 45 B
0.6040	GG40	EN-GJL-350	Ft35D	GRADE350	FC 35	G35	0135-00	FG 35	–
Cast iron									
Spheroidal graphite cast iron									
0.7040	GGG-40	EN-GJS-400-15	FGS 400-12	SNG 420/12	FCD 400	GS 400/12	07 17-02	FGE 38-17	40-60-18
0.7050	GGG-50	EN-GJS-500-7	FGS 500-7	SNG 500/7	FCD 500	GS 500/7	07 27-02	FGD 50-7	45-65-12
0.7060	GGG-60	EN-GJS-600-3	FGS 600-7	SNG 600/3	FCD 600	GS 600/3	07 32-03	FGE 60-2	55-80-06
0.7070	GGG-70	EN-GJS-700-2U	FGS 700-2	SNG 700/2	FCD 700	GS 700/2	07 37-01	FGS 70-2	70-100-03
0.7080	GGG-80	E8N-GJS-800-2	FGS 800-2	SNG 800/2	FCD 800	GS 800/2	–	–	90-120-02
Cast iron									
Hardened cast metal									
GTS 35-10	EN-GJMB-350-10	MN 35-10	B 340/12	–	–	08 15	–	32510	–
GTS 45-06	EN-GJMB-450-6	–	P 440/7	–	–	08 52	–	40010	–
GTS 55-04	EN-GJMB-550-4	MP 50-5	P 510/4	–	–	08 54	–	50005	–
GTS 65-02	EN-GJMB-650-2	MP 60-3	P 570/3	–	–	08 85	–	70003	–

M No.	DIN	European standard	France AFNOR	Great Britain BS	Japan JIS	Italy UNI	Sweden SS	Spain U.N.E./I.H.A	USA AISI/SAE
-------	-----	-------------------	--------------	------------------	-----------	-----------	-----------	--------------------	--------------

NF metals/non-metals
Aluminum

3.0255	Al99.5	EN-AW-1050A	A59050C	L31/L34/L36	-	-	-	-	1000
3.1325	AlCuMg1	EN-AW-2017A	-	-	-	-	-	-	-
3.2163	G-AlSi9Cu3	EN-AC-46200	-	-	-	-	-	-	-
3.2315	AlMgSi1	EN-AW-6082	-	-	-	-	-	-	-
3.2383	G-AlSi10Mg	-	-	LM 9	-	-	4253	-	A 360.2
3.2581	G-AlSi12	EN-AW-2017A	-	LM 6	-	-	4261	-	A 413.2
3.3535	AlMg3	EN-AW-5754	-	-	-	-	-	-	-
3.4345	AlZnMgCu0.5	EN-AW-7022	AZ4GU/9051	L 86	-	-	-	-	7050
3.5105	GMgZn4 SE1Zr1	-	G-Z4TR	MAG 5	-	-	-	-	ZE 41
3.5812	G-MgAl8Zn1	-	G-A9	MAG 1	-	-	-	-	AZ 81

NF metals/non-metals
Copper

-	CuMn5F36	-	-	-	-	-	-	-	-
-	CuSi2MnF34	-	-	-	-	-	-	-	-
-	E-Cu57	-	-	-	-	-	-	-	-
-	CuZn15	-	CuZn 15	CZ 102	-	-	-	-	C 23000
-	CuZn30	-	CuZn 30	CZ 106	-	-	-	-	C 26000
-	CuZn37	-	CuZn 37	CZ 108	-	C2720	-	-	C 27700
-	CuZn36Pb3	-	-	-	-	-	-	-	-
-	G-CuZn34Al2	-	U-Z36N 3	HTB 1	-	-	-	-	C 86200
-	G-CuSn5ZnPb	-	U-E5Pb5Z5	LG 2	-	-	-	-	C 83600
-	G-CuPb10Sn	-	U-E10Pb10	LB 2	-	-	-	-	C 93700
-	CuCrZr	-	U-Cr 0.8 Zr	CC 102	-	-	-	-	C 18200

NF metals/non-metals
Graphite

-	ISO-63	-	-	-	-	-	-	-	-
-	ISO-90	-	-	-	-	-	-	-	-
-	ISO-93	-	-	-	-	-	-	-	-
-	ISO-95	-	-	-	-	-	-	-	-

NF metals/non-metals
Plastics

-	Ureol® 5211 A/B	-	-	-	-	-	-	-	-
-	Ureol® 5212 A/B	-	-	-	-	-	-	-	-
-	Ureol® 5213 A/B	-	-	-	-	-	-	-	-
-	Ureol® 5214 A/B	-	-	-	-	-	-	-	-
-	Ureol® 5215 A/B	-	-	-	-	-	-	-	-
-	Ureol® 5216 A/B	-	-	-	-	-	-	-	-
-	Ureol® 5217 A/B	-	-	-	-	-	-	-	-
-	Ureol® 5218 A/B	-	-	-	-	-	-	-	-
-	Ureol® 5219 A/B	-	-	-	-	-	-	-	-

Material overview with comparison table

M No.	DIN	European standard	France AFNOR	Great Britain BS	Japan JIS	Italy UNI	Sweden SS	Spain U.N.E./I.H.A	USA AISI/SAE
Hardened materials									
up to 48HRC									
1.2311	40Cr MnMo7	35CrMo 8	–	–	–	35CrMo 8 KU	–	–	–
1.2312	40Cr MnMoS8-6	–	–	–	–	–	–	–	–
1.2323	48Cr MoV6-7	–	–	–	–	–	–	–	–
1.2343	X38Cr MoV5-1	X37CrMoV5-1	Z38CDV 5	BH 11	SKD 6	X37CrMo V51 KUa	X37CrMoV5-1	F.520.G	H 11
1.2344	X40Cr MoV51	X40CrMoV5-1	Z40CDV 5	BH 13	SKD 61	X40CrMo V 5 1 1 KU	2242	X40CrMo V 5-1	H 13
1.2842	90MnCrV8	90MnCrV8	90Mv8	BO 2	–	90MnVCr 8 KU	90MnCrV8	F.5229	O 2
Hardened materials									
up to 48HRC									
1.2080	X210Cr12	X210Cr12	Z200C12	BD 3	SKD 1	X210Cr12	X210Cr12	F.521	D 3
1.2323	48CrMoV6-7	–	–	–	–	–	–	–	–
1.2344	X40Cr MoV5-1	X40CrMoV5-1	Z40CDV5	BH 13	SKD 61	X40CrMoV5-1	2242	X40CrMoV5-1	H 13
1.2363	X100Cr MoV51	X100CrMoV5	Z100CDV5	BA 2	SKD 12	X100CrMoV5	2260	X100CrMoV5	A 2
1.2369	81MoCrV 42-16	–	–	–	–	–	–	–	613
1.2379	X155CrV Mo12-1	X153CrMoV12	Z160CDV12	BD 2	SKD 11	X153CrMoV12	2310	X153CrMoV12	D 2
1.2567	30WCrV17-2	X30WCrV53	–	–	SKD 4	–	–	–	–
1.2708	54NiCrMoS6	–	–	–	–	–	–	–	–
1.2713	55NiCrMoV6	55NiCrMoV7	55NCDV7	–	SKT 4	–	–	F.520.S	L 6
1.2738	40CrMnNi Mo8-6-4	40CrMnNi Mo8-6-4	40CrMnNi Mo8-6-4	40CrMnNi Mo8-6-4	40CrMnNi Mo8-6-4	40CrMnNi Mo8-6-4	40CrMnNi Mo8-6-4	40CrMnNi Mo8-6-4	40CrMnNi Mo8-6-4
1.2767	X45NiCrMo4	45NiCrMo16	45NiCrMo16	45NiCrMo16	SKT 6	45NiCrMo16	45NiCrMo16	45NiCrMo16	–
1.2842	90MnCrV8	90MnCrV8	90MnCrV8	BO 2	–	90MnCrV8	90MnCrV8	90MnCrV8	O 2
Hardened materials									
up to 55HRC									
1.2080	X210Cr12	X210Cr12	Z200C12	BD 3	SKD 1	X210Cr12	X210Cr12	X210Cr12	D 3
1.2363	X100Cr MoV5	X100CrMoV5	Z100CDV5	BA 2	SKD 12	X100CrMoV5	2260	X100CrMoV5	A 2
1.2369	81MoCrV 42-16	–	–	–	–	–	–	–	613
1.2379	X153Cr MoV12	X153CrMoV12	Z160CDV12	BD 2	SKD 10	X153CrMoC12	2310	X153CrMoC12	D 2
1.2767	45NiCr Mo16	45NiCrMo16	45NiCrMo16	45NiCrMo16	SKT 6	45NiCrMo16	45NiCrMo16	45NiCrMo16	–
1.2842	90MnCrV8	90MnCrV8	90MnCrV8	BO 2	–	90MnCrV8	90MnCrV8	90MnCrV8	O 2

Hardness comparison table

Tensile strength, Vickers, Brinell and Rockwell hardness

Tensile strength R_m N/mm ²	Vickers hardness HV10	Brinell hardness HB	Rockwell hardness HRC
255	80	76.0	–
270	85	80.7	–
285	90	85.5	–
305	95	90.2	–
320	100	95.0	–
335	105	99.8	–
350	110	105	–
370	115	109	–
385	120	114	–
400	125	119	–
415	130	124	–
430	135	128	–
450	140	133	–
465	145	138	–
480	150	143	–
495	155	147	–
510	160	152	–
530	165	156	–
545	170	162	–
560	175	166	–
575	180	171	–
595	185	176	–
610	190	181	–
625	195	185	–
640	200	190	–
660	205	195	–
675	210	199	–
690	215	204	–
705	220	209	–
720	225	214	–
740	230	219	–
755	235	223	–
770	240	228	20.3
785	245	233	21.3
800	250	238	22.2
820	255	242	23.1
835	260	247	24.0
850	265	252	24.8
865	270	257	25.6
880	275	261	26.4
900	280	266	27.1
915	285	271	27.8
930	290	276	28.5
950	295	280	29.2
965	300	285	29.8
995	310	295	31.0
1030	320	304	32.2
1060	330	314	33.3
1095	340	323	34.4
1125	350	333	35.5

Tensile strength R_m N/mm ²	Vickers hardness HV10	Brinell hardness HB	Rockwell hardness HRC
1155	360	342	36.6
1190	370	352	37.7
1220	380	361	38.8
1255	390	371	39.8
1290	400	380	40.8
1320	410	390	41.8
1350	420	399	42.7
1385	430	409	43.6
1420	440	418	44.5
1455	450	428	45.3
1485	460	437	46.1
1520	470	447	46.9
1555	480	456	47.7
1595	490	466	48.4
1630	500	475	49.1
1665	510	485	49.8
1700	520	494	50.5
1740	530	504	51.1
1775	540	513	51.7
1810	550	523	52.3
1845	560	532	53.0
1880	570	542	53.6
1920	580	551	54.1
1955	590	561	54.7
1995	600	570	55.2
2030	610	580	55.7
2070	620	589	56.3
2105	630	599	56.8
2145	640	608	57.3
2180	650	618	57.8
–	660	–	58.3
–	670	–	58.8
–	680	–	59.2
–	690	–	59.7
–	700	–	60.1
–	720	–	61.0
–	740	–	61.8
–	760	–	62.5
–	780	–	63.3
–	800	–	64.0
–	820	–	64.7
–	840	–	65.3
–	860	–	65.9
–	880	–	66.4
–	900	–	67.0
–	920	–	67.5
–	940	–	68.0

Classification of cutting material types indexable insert milling

by material group / key application under ISO 513

Type designation	Application area											Material group:					
	1	5	10	15	20	25	30	35	40	45	50	P Steel	M Stainless	K Cast iron	N Non-ferrous metals	S High-temperature resistant	H Hardened materials
Standard designation																	
CBN steel																	
BN-K10			■														●
CBN cast iron																	
BN-K20					■												●
HSC 05 PVTi																	
HC-P10			■	■								●					
HC-K05	■	■	■	■										○			
HSC 05 PVFN																	
HC-P10			■	■								●					
HC-K05	■	■	■	■										○			●
K 10																	
HW-M15			■	■									○				
HW-K10			■	■									●				
K10 PVTi																	
HC-M15			■	■									○		○		
HC-K10	■	■	■	■										●			○
P25 PVGO																	
HC-P25					■	■	■	■				○					
HC-M25					■	■	■	■				●			●		
P25 PVTi																	
HC-P25					■	■	■	■				●					
HC-K20					■	■	■	■						○			
P40 PVTi																	
HC-P40								■	■			●					
P40 PVGO																	
HC-P35								■	■	■		●					
HC-M35								■	■	■		○					
HC-K30								■	■	■				●			
P40 PVSR																	
HC-P30								■	■	■		●					
HC-K25								■	■	■				○			○
P40 PVML																	
HC-P35								■	■	■		●					
HC-M35								■	■	■		○					
M40 PVST																	
HC-P40								■	■	■		○					
HC-M40								■	■	■		●			●		
P40 PCSR																	
HC-P35								■	■	■		●					
HC-K30								■	■	■				○			
M35 PCTC																	
HC-M35								■	■	■		○					
HC-S30								■	■	■				●			
K10 PPTi																	
HC-K10			■	■													●
HC-P10			■	■								●		○			●

- Primary application
- Secondary application

Filled in circles indicate the main application area, and are color coded by material classification. The peak of the pentagon shows the main inclination, while lines falling to the right and left show the expanded range of application. Possible secondary applications for the cutting material types are described by colored rings.

Diagram

To divide the main types of milling by wear resistance / toughness

This diagram shows the relationship between wear resistance and toughness in primary types of milling. It illustrates the expanded work area, and shows where the cutting material types complement one another, or indicates when another main type can be used in different wear cases.

In addition, it makes clear the diversity of available options.

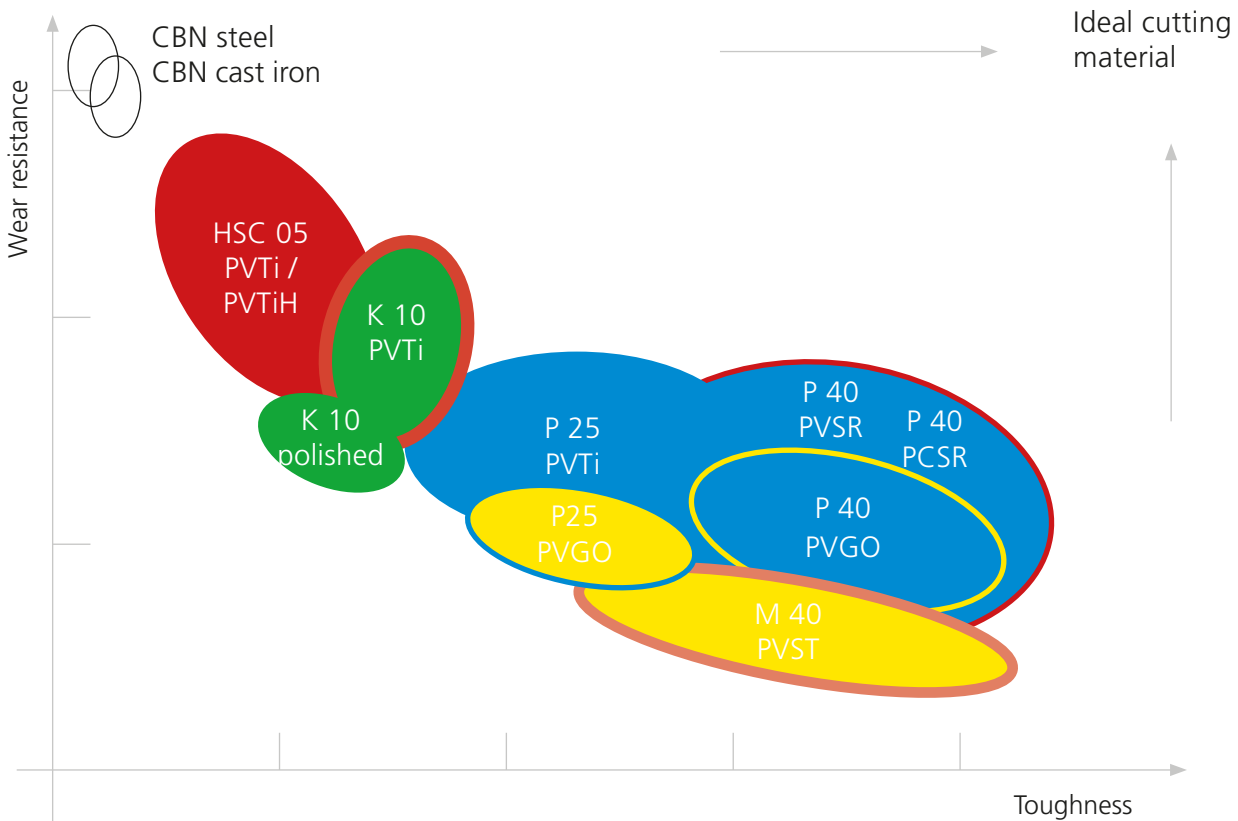

Designations in accordance with ISO 1832

Indexable Inserts

One example according to DIN ISO 1832¹ is composed as follows:

R

1

Indexable insert shape

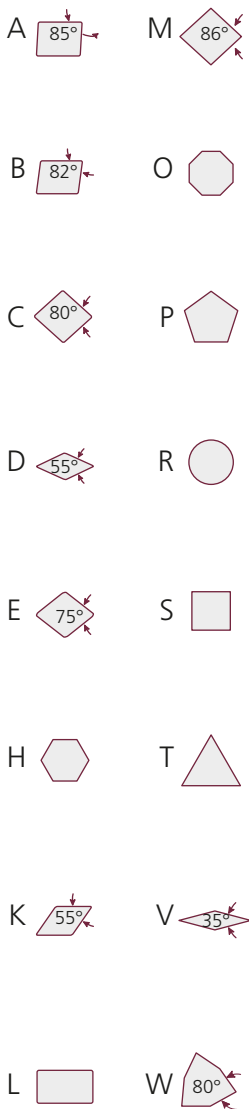

D

2

Clearance angle

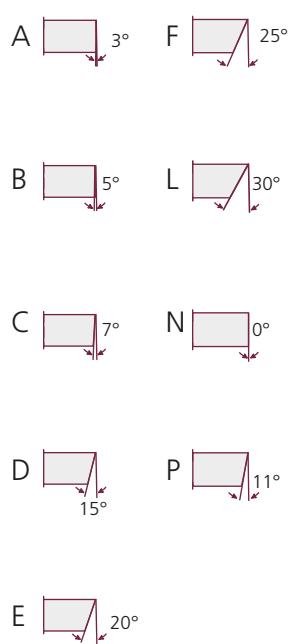

0 For other relief that requires more detailed information

H

3

Tolerances

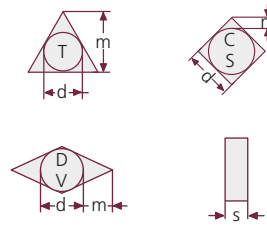

	d	m	s
A	± 0.025	± 0.005	± 0.025
C	± 0.025	± 0.013	± 0.025
E	± 0.025	± 0.025	± 0.025
F	± 0.013	± 0.005	± 0.025
L	± 0.025	± 0.025	± 0.05-0.13
H	± 0.013	± 0.013	± 0.025
J1	± 0.05-0.15 ²	± 0.005	± 0.025
K1	± 0.05-0.15 ²	± 0.013	± 0.025
L1	± 0.05-0.15 ²	± 0.025	± 0.025
M	± 0.05-0.15 ²	± 0.02-0.08 ²	± 0.05-0.13
N	± 0.05-0.15 ²	± 0.02-0.08 ²	± 0.025
U	± 0.08-0.15 ²	± 0.13-0.38 ²	± 0.13

¹ Inserts with ground wiper edge

² Depending on insert size (see ISO standard 1832)

X

4

Machining and fastening characteristics

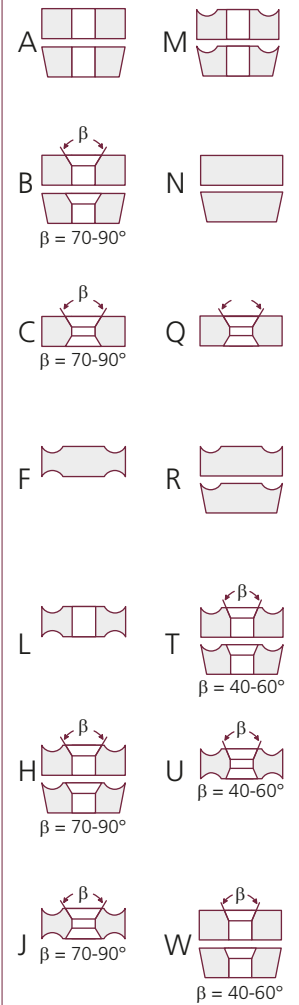

X With dimensions or features that require detailed information

16 04 M0 T N -

5

Cutting flute length

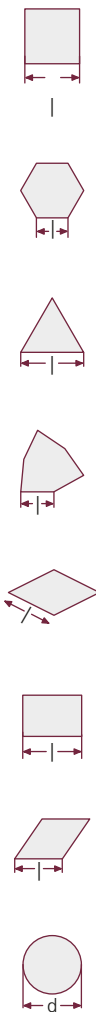

6

Insert thickness

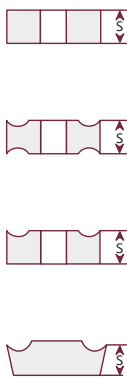

- s = 1.59 01
- s = 1.98 T1
- s = 2.38 02
- s = 2.78 T2
- s = 3.18 03
- s = 3.97 T3
- s = 4.76 04
- s = 5.56 05
- s = 6.35 06
- s = 7.94 07
- s = 9.52 09

7

Wear land, relief, radius

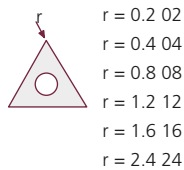

Relief on the wiper edge

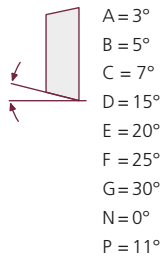

Z = other relief



00 For diameter with inch dimensions converted to mm

M0 For diameter in metric measurements.

Entering angle χ_r

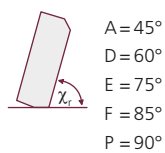

Z = Other entering angle

8

Cutting flute design

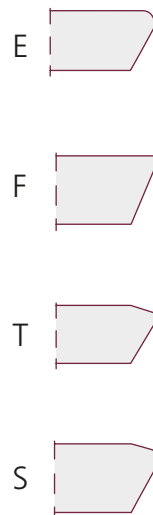

9

Feed direction

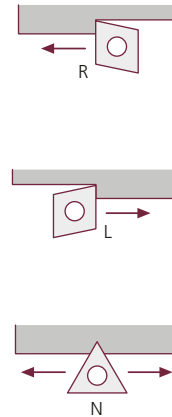

10

Manuf. information

One or two character symbol to be freely assigned (numbers or letters) at the discretion of the manufacturer. Must be separated from the previous symbols by a dash (-).

regarding
regarding

5 + 6
8 + 9

digits behind the comma are not taken into consideration. A "zero" is added first for single digit codes (such as 04 for 4.76 mm).
the symbols 8 and/or 9 are only used as needed.

Coating overview

Indexable Inserts

Coating designation		Color	Vickers microhardness HV	Operating temperature in degrees	Coating type	Coating thickness in μm
PVTi	TiAlN	blue/gray	3600	up to 850°	PVD	2 to 4
PVDiaN	Diamond coating	matte/gray	10000	up to 600°	CVD	6 to 8
PVSR	–	black	1420 HV30	up to 1000°	CVD	4 to 6.5
PVGM	–	gold	1280 HV30	up to 650°	CVD	2 to 3.5
PVML	TiAlSiN	gold	3300	800° to 850°	PVD	2.5 to 5
PVFN	PVFN	blue/gray	3300	up to 950°	PVD	2 to 4
PVGO	TiAlN + TiN	yellow/gold	3150	900°	PVD	2 to 4.5
PVTiH	TiAlN Multilayer	purple/brown	3600	up to 1100°	PVD	4 to 5
PVST	AlTiN	blue/gray	3300	up to 950°	PVD	2 to 4
PCSR	–	black	1450 HV 30	up to 900°	CVD	8 to 10
PCTC	–	silver	1530 HV 30	up to 1000°	CVD	6 to 7
PPTi	nc-TiAlN	black/gray	3600	up to 900°	PVD	3 to 5
PATM	AlTiN Multilayer	black/gray	3500	up to 1100°	CDC	6
PATG	AlTiN Multilayer	gold	3600	up to 900°	PVD	2 to 4

Cutting material overview

Cutting material	Coatings	Steel	High-temperature resistant alloys	Stainless steel	Cast iron	Non-ferrous metals	Hardened materials	
P40	PVTi		-	-	-	-	-	Coated, very tough standard type for roughing of steel at moderate speed, for even longer service lives
P40	PVGO		-			-	-	Coated, very tough standard type for pre-finishing and roughing steel. To be used at moderate to high speeds, in some cases also suitable for machining cast iron and stainless steels.
P40	PVSR		-	-		-		High-durability specialized type for pre-finishing and roughing steel at moderate speed and extremely high feed per tooth
P40	PVGM				-	-	-	Coated, very tough specialized type for medium and rough machining of stainless, high-temperature resistant steels and titanium
P40	PVML		-			-		Coated, tough specialized type for pre-finishing and roughing steel, at moderate to high speeds, in some cases also suitable for finishing and machining cast iron and stainless materials
P25	PVTi		-	--		-	-	Coated, tough standard type for finishing and pre-finishing steel at moderate speed, for even longer service lives
K10	polished							Uncoated standard type for pre-finishing cast iron, NF metals, graphite
K10	PVTi							Coated standard type for finishing steel at moderate speed
K10	PVDiaN	-	-	-	-		-	Diamond coated basic type specially for finishing aluminum and graphite in the HSC area
K05	PVTi							Coated standard type for finishing steel, hardened steel and cast iron in the top speed range
HSC05	PVTi PVTiH		-					Coated, optimized specialized type for machining steel, hardened steel and cast iron in the HSC area, as well as graphite and plastics
HSC05	PVFN		-	-		-		Extremely wear-resistant, coated specialized type for machining steel, hardened steel, and cast iron at high to very high speeds.
CBN C	-	-	-	-		-	-	CBN type specially designed for finishing cast iron in HSC
CBN S	-	-	-	-	-	-		CBN type specially designed for finishing hardened steel above 48 HRC in the HSC area
PKD	-	-	-	-	-		-	Universal PKD type for finishing non-ferrous metals and plastics in HSC
P40	PCSR		-	-	-	-	-	Specialized type optimized for toughness with thick CVD coating. Specially designed for high speeds and high feed per tooth
M35	PCTC	-			-	-	-	Cemented carbide with high temperature stability and customized CVD coating. Developed for dry machining of stainless materials, as well as wet cutting of superalloys like titanium and Inconel.
K10	PPTi	-	-	-	-		-	Ultrafine grain type for high-speed machining with low engagement. Novel, extra-smooth PVD coating for cutting steel, cast iron, and hardened materials. Can be used wet and dry

Formulas and example calculations

Formulas

Calculation of spindle revolutions in [min⁻¹]:*

$$n = \frac{V_c \cdot 1000}{\pi \cdot D_{c/eff}}$$

Calculation of speed in [m/min]:*

$$V_c = \frac{\pi \cdot D_{c/eff} \cdot n}{1000}$$

* Please note that on flat contours, the effective tool diameter must be used for the calculation (see the surface grade section).

Calculation of feed per tooth in [mm/min]:

$$f_z = \frac{V_f}{n \cdot z}$$

Calculation of feed per revolution in [mm/r]:

$$f_n = z \cdot f_z$$

$$f_n = \frac{V_f}{n}$$

Calculation of feed rate in [mm/min]:

$$V_f = n \cdot z \cdot f_z$$

Calculation of machining time in [min]:

$$T = \frac{l_f}{V_f}$$

Calculation of required machine power in [kW]:

$$P = \frac{a_e \cdot a_p \cdot V_f}{18000}$$

Calculation of chip volume in [cm³/min]:

$$Q = \frac{a_e \cdot a_p \cdot V_f}{1000}$$

* Please note: This formula is used to calculate machine performance when machining steel.

Definition of terms

a_e Width of cut in (mm)
 a_p Depth of cut in (mm)
 D_c Cutter diameter in (mm)

D_{eff} Effective tool diameter
 f_z Feed per tooth in (mm/tooth)
 l_f Total milling length in (mm)
 f_n Feed per revolution in (mm/r)

n Spindle revolutions in [rpm]
 P (Required) machine power in [kW]
 Q Chip volume in [cm³/min]
 T Machining time in [min]

V_c Speed in (m/min)
 V_f Feed rate in (mm/min)
 z Effective no. of teeth

Formulas for calculating the effective tool diameter are available in the surface grade section.

Example calculation

Cutters:	35 200
Selected indexable insert: (acc. to table)	03 12 8242k (P40, PATM coated)
Indexable insert size:	Ø 12 x 3.97 mm
Cutter diameter:	35 mm
Effective no. of teeth:	3
Depth of cut: (acc. to table)	1.5 mm
Width of cut:	25 mm
Material to be machined:	1.1730, roughing
Selected speed: (acc. to cutting parameter table)	$V_c = 250$ m/min
Selected feed per tooth: (acc. to cutting parameter table)	$f_z = 0.6$ mm

Calculation of speed:

$$n = \frac{250 \cdot 1000}{\pi \cdot 35} = 2275 \text{ U/min}$$

Calculation of feed rate:

$$V_f = 2275 \cdot 3 \cdot 0,6 = 4095 \text{ mm/min}$$

Calculation of chip volume:

$$Q = \frac{(25 \cdot 1,5 \cdot 4095)}{1000} = 154 \text{ cm}^3/\text{min}$$

Calculation of required machine power:

$$P = \frac{(25 \cdot 1,5 \cdot 4095)}{18000} = 8,5 \text{ kW}$$

Assembly instructions

Pokolm DuoPlug®

To ensure optimal, secure fit of the DuoPlug® system, please observe the following instructions.

Assembly:

Preparations

Keep accessory tools (wrench, protective glasses, gloves) ready before warming up the work station.

Step 1

Remove the indexable inserts and their fastening screws.

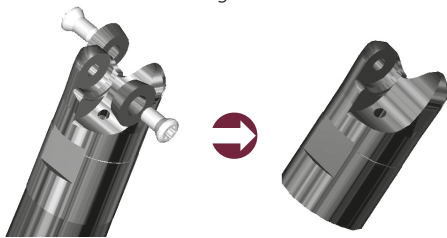

Step 2

Warning! The fit surfaces of the tool and arbor system must be absolutely free from dirt or grease. The DuoPlug® milling body must be screwed into the fit zone manually.

Do not use tools!



Step 3

Inductive heating with Pokolm induction shrinking unit for 6 to 15 seconds depending on the diameter. Then, start immediately with step 4.

Caution! Arbor and tool will be very hot afterwards!

Danger of burning!

Always wear gloves!



Step 4

The fitted bore of the tool will expand when heated. Only then can the tool be tightened to the stop surface of the adapter using an appropriate wrench. It should be possible to complete this step without excess force. If not, heat the DuoPlug®-mill body once again for a few seconds.



Step 5

Ensure that the tool and arbor are flat against one another. There may be no remaining gap.

Only complete these steps with moderate force.



Step 6

The shrink fit tool adapter unit may not be quenched, but should be cooled evenly using the cooling unit on the shrinking unit. Cooling the tool will cause the DuoPlug® milling body to draw back together. A frictional and positive-locking connection will be formed.



Step 7

Now, fit the tool with the desired indexable inserts. After measuring, you can start machining.



Disassembly:

Preparations

Keep accessory tools (wrench, protective glasses, gloves) ready before warming up the work station.

Always wear safety glasses during disassembly, since there is a risk of spray when coolant and lubricant residues are heated up.

Step 1

First, remove the indexable inserts and their fastening screws again.

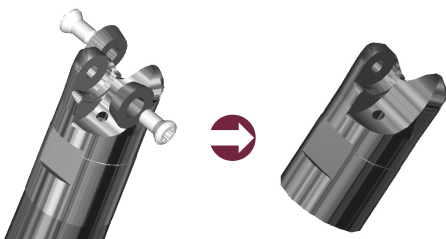

Step 2

Inductive heating with Pokolm induction shrinking unit for 6 to 15 seconds depending on the diameter.

Caution! Arbor and tool will be very hot afterwards!

Danger of burning!

Always wear gloves!



Of course, we are also happy to assist you with further questions on the DuoPlug® system.

Step 3

Inductive heating will cause the fitted bore of the tool to expand. **Only then** can the milling body be unscrewed from the adapter with an appropriate screw. It should be possible to complete this step without excess **force**. If not, heat the **DuoPlug®**-mill body once again for a few seconds.



Step 4

The unshrunk components may not be quenched. Instead, cool them down slowly using the cooling device on the shrinking unit, or use the storage station.

Caution! Arbor and tool will still be very hot!

Danger of burning!

Always wear gloves!



Recommendation

For shrink gripping, we recommend our convenient TS111000WK induction shrinking station, with a variety of innovative properties. Optimally designed to work with POKOLM products, the shrinking and liquid-supported cooling process is carried out semi-automatically in one position on the device. The operating concept is very user-friendly.

For further information, please request the brochure from Pokolm shrink grip technology. It is also available in the download area of our website, or simply scan the QR code:



Assembly instructions

for round insert cutters with shim

To ensure optimal and secure fit of the tool please observe the following instructions during assembly.

Assembling indexable inserts: Exchanging the shim:

Step 1.1

Remove the Torx screw (5) using the Torx wrench (7) and check the threaded bush (3) using the included Allen wrench (4).

Step 1.2

If the threaded bush (3) can be tightened further, then tighten it manually using the Allen wrench (4). Ensure that the collar of the threaded bush (3) sinks into the sink of the shim (2).

Step 1.3

Use the Torx wrench (7) to first install the indexable insert, then fix it in place using the locking screw (6).

Step 2.1

To exchange the shim, please have the relevant Torx wrench (7) and the Allen wrench included in the delivery (4) ready.

Step 2.2

Loosen the locking screw using a Torx wrench (7), then remove the Torx screws (5) using the Torx wrench (7).

Step 2.3

Now, use the Allen wrench (4) to loosen and remove the threaded bush (3). You can now remove the shim (2) from the tool. Before inserting the new shim (2), please clean the insert seat and ensure it is free from chips and oil.

Step 2.4

Insert the shim (2) into the insert seat and fasten it using the threaded bush (3) and Allen wrench (4); to do so, please use the copper paste available from Pokolm. Ensure that the collar of the threaded bush (3) sinks into the sink of the shim (2).

Step 2.5

Now, you can insert the indexable inserts (8) as usual and fasten them using the Torx screw (5) and Torx wrench (7). Then, tighten the locking screw (6) to ensure the indexable insert fits securely.

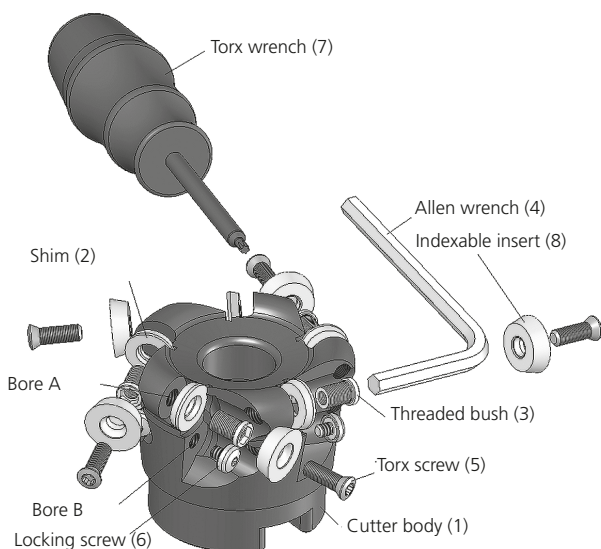

Assembly instructions

Setscrew for various shell-type milling cutters Ø 40 to 52 mm

To ensure optimal and secure fit of the tool please observe the following instructions during assembly of the setscrew (Art. No. GWSTPS8ISK).

Setscrew assembly

Step 1

Screw the setscrew into the milling body to the stop. This is secured at the Pokolm factory. However, in rare and exceptional cases, the setscrew can come loose during transportation, and will need to be readjusted.

Step 2

Set the milling body on the milling arbor for assembly. Ensure that there is a gap of approx. 4 mm between the tool and arbor. (This is ensured when using Pokolm arbors).

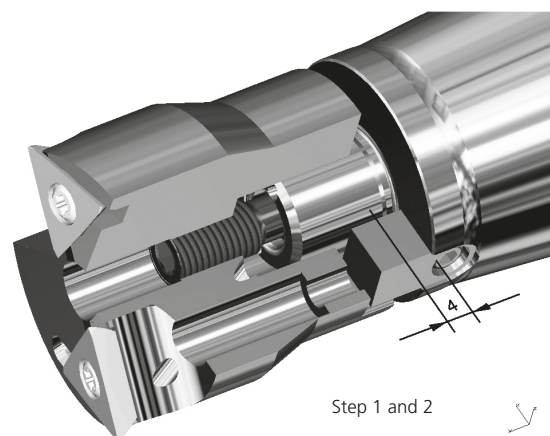

Step 3

Now, screw the setscrew evenly into the arbor. You will need an Allen wrench of nominal size SW 4 mm to do so. The setscrew must be screwed in until there is no longer a visible gap between the arbor and the milling body.

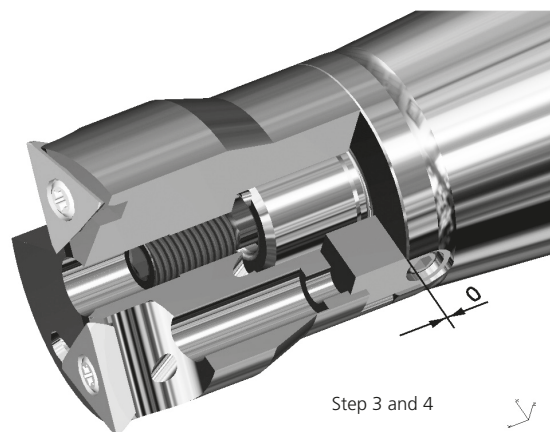

Step 4

If a visible gap remains, contrary to expectations, then the setscrew must be readjusted in the cutter body to correct this. To do so, please loosen the cutter body from the milling arbor completely, and unscrew the setscrew approx. a ½ turn from the milling tool. Continue with step 1.2

Please note:

Maximum tightening torque = 10 Nm

Of course, we are happy to assist you with further questions regarding setscrew systems.

Assembly instructions

for SPINWORX® cutting inserts

To ensure optimal and secure fit of the tool please observe the following instructions during assembly.

Step 1: Inserting the cutting insert

Insert the cutting insert in the provided insert seat. Apply the included paste, article no. "Z 00043" to the thread of the pin and make sure no paste gets onto the contact surface. Remove any excess before using the tool.

Step 2: Assembling the pin

Insert the pin into the screw fitting from behind and use the torque wrench to tighten according to the specified tightening torque. We recommend using our pre-set torque wrench to do so.

Tightening torques

Insert	Torx size	Torque adapter
DR07-8	T6	DM04
DR10-8 DR12-8	T10	DM10
DR16-8 DR20-8	T20	DM22

Please note:

Simple handling thanks to a convenient tool: We recommend our torque wrench with pre-set tightening torque as a convenient and safe alternative to conventional Torx or torque wrenches.

For optimal results with the SPINWORX® tool system, we recommend using an internal coolant supply, air, emulsion, or MMS in the tool for chip removal.

Order form

Your faxed order

Please copy first, then fill out!

Please fax to: Pokolm
0800 0765656 (free call)

You are also always welcome to place an order with your sales representative.

Item number	Article designation	Order quantity	Unit price	Total price
Total				

Billing address and delivery address:

Delivery address, if different:

Company: _____

Customer number: _____

Company: _____

Department: _____

Street _____

Street _____

Contact person: _____

Zip code, City _____

Zip code, City _____

Item number index

Part no.	0	Page	Part no.	0	Page	Part no.	0	Page
01 07 8035		85	02 11 860		138	03 48 842		189
01 07 8042		85	02 11 860		140	03 48 846		189
01 07 831 P		85	02 11 860 D		138	03 48 848		189
01 07 880		85	02 11 860 D		140	03 48 850		189
01 07 880 D		85	02 66 820 R20		169	03 48 852		189
02 07 8035		88	02 66 835 R08		37	03 48 8035		189
02 07 8042		88	02 66 835 R08 D		37	03 48 896		189
02 07 8099		88	02 66 835 R20		169	03 83 835		30
02 07 831P		88	02 66 835 R20 D		169	03 83 836		30
02 07 846		88	02 66 836 R20		169	03 85 835		125
02 07 848		88	02 66 860 R20		169	03 85 835 D		125
02 07 880		88	02 66 890 R20		169	03 85 836		125
02 07 880 D		88	02 79 8035		128	03 85 892		125
02 07 892		88	02 79 831P		128	03 85 894		125
02 07 896		88	02 79 835 R2		131	04 16 8035		113
02 07 897		88	02 79 880		128	04 16 8035		113
02 10 8035		92	02 79 880 D		128	04 16 8035		116
02 10 8035		97	02 79 892		128	04 16 8042		113
02 10 8042		92	02 79 894		128	04 16 8042		116
02 10 8042		97	03 12 8035K		104	04 16 8099		113
02 10 8099		92	03 12 8035K		108	04 16 8099		116
02 10 8099		97	03 12 8042K		104	04 16 8242		113
02 10 831P		92	03 12 8042K		108	04 16 8242		116
02 10 831P		97	03 12 8099K		104	04 16 831P		113
02 10 844		92	03 12 8099K		108	04 16 831P		116
02 10 844		97	03 12 8242K		104	04 16 844		113
02 10 846		92	03 12 8242K		108	04 16 844		116
02 10 846		97	03 12 831P		104	04 16 848		113
02 10 848		92	03 12 831P		108	04 16 848		116
02 10 848		97	03 12 837K		104	04 16 852		113
02 10 852		92	03 12 837K		108	04 16 852		116
02 10 852		97	03 12 846K		104	04 16 880		113
02 10 860		97	03 12 846K		108	04 16 880		116
02 10 880		92	03 12 848K		104	04 16 896		113
02 10 880		97	03 12 848K		108	04 16 896		116
02 10 880 D		92	03 12 852K		104	04 16 897		113
02 10 880 D		97	03 12 852K		108	04 16 897		116
02 10 892		92	03 12 860K		108	04 20 850		150
02 10 892		97	03 12 880		104	04 49 842		192
02 10 893		92	03 12 880		108	04 49 846		192
02 10 893		97	03 12 880 D		104	04 49 852		192
02 10 896		92	03 12 880 D		108	04 49 860		192
02 10 896		97	03 12 896K		104	04 49 896		192
02 10 897		92	03 12 896K		108	04 67 8099 HF		177
02 10 897		97	03 12 897K		104	04 67 8099 R08		39
02 11 820		138	03 12 897K		108	04 67 820		39
02 11 820		140	03 16 850		150	04 67 820 R04		39

Part no.	0	Page
04 67 820 R08		39
04 67 820 R20		39
04 67 820 R30		39
04 67 820 R40		39
04 67 835 HF		177
04 67 836 HF		177
04 67 837		39
04 67 837 R08		39
04 67 844		39
04 67 848		39
04 67 848 HF		177
04 67 848 R08		39
04 67 860		39
04 67 860 D		39
04 67 862 HF		177
04 67 894		39
04 67 896		39
04 67 896 HF		177
04 67 896 R08		39
04 67 896 R20		39
04 67 896 R30		39
04 67 896 R40		39
04 79 835		133
04 84 835		32
04 84 835 EC		32
05 22 820		144
05 22 820		146
05 22 860		144
05 22 860		146
05 22 860 D		144
05 22 860 D		146
05 25 850		150
05 31 8096		26
05 31 842		26
05 31 862		26
05 51 8242 HF		195
05 51 848		48
05 51 848 HF		195
05 51 852 HF		195
05 51 858		48
05 51 858 HF		195
05 51 860 HF		195
05 51 862 HF		195
05 51 868 HF		195
05 51 896		48
05 51 896 HF		195
05 68 820		43

Part no.	0	Page
05 68 820 R20		43
05 68 820 R30		43
05 68 820 R40		43
05 68 820 R50		43
05 68 848		43
05 68 862		43
05 68 896		43
05 68 896 R20		43
05 68 896 R30		43
05 68 896 R40		43
05 68 896 R50		43
06 20 831P		120
06 20 835		120
06 20 840		120
06 20 850		120
06 20 860		120
06 20 880		120
06 32 850		150
08 093 V R3		156
08 214		154
08 214 M6		154
08 835 V		156
08 835 V R3		156
08 836 V		156
08 836 V R3		156

Part no.	1	Page
1 16 283		30
1 16 283 SG		30
10 093 V R4		156
10 100 331		26
10 214 M6		154
10 214 SG		154
10 214 SV		154
10 215 M6		160
10 215 M6		163
10 215 SG		160
10 215 SG		155
10 835 V		156
10 835 V R4		156
10 836 V		156
10 836 V R4		156

Part no.	1	Page
100 15 100		87
100 20 100		91
100 300		115
100 300/7		115
100 300/7 HL		112
100 340/7		119
100 360		146
12 093 V R5		156
12 125 331		26
12 200		84
12 200 M6		84
12 214 M6		154
12 214 SG		154
12 214 SV		154
12 215 M6		160
12 215 M6		163
12 215 SG		160
12 215 SG		163
12 835 V		156
12 835 V R5		156
12 836 V		156
12 836 V R5		156
120 20 100		91
125 300/7		115
125 340/7		19
125 360		146
14 160 331		26
15 10 8060 HF		164
15 10 8060 R05		161
15 12 8060 HF		164
15 12 8060 R05		161
15 16 8060 HF		164
15 16 8060 R10		161
15 20 8060 HF		164
15 20 8060 R10		161
15 200		87
15 261		138
15 261-3		140
16 093 V R7		156
16 200 331		26
16 214		155
16 214 SG		154
16 214 SV		155
16 215		160
16 215		163
16 215 SG		160
16 215 SG		163

Item number index

Part no.	1	Page	Part no.	2	Page	Part no.	3	Page
16 261		138	2 30 283		30	3 12 266 M6		36
16 261 SG		138	2 32 16 167 G		38	3 12 266 M6		168
16 261-3		140	2 32 16 167 G		176	3 12 266 SG		36
16 261-3 SG		140	2 32 16 185 G		124	3 12 266 SG		168
16 275		150	2 32 251		48	3 15 235		84
16 281		128	2 32 251		194	3 15 235 SG		84
16 281 SG		128	2 32 283		30	3 16 200		87
16 282		131	2 35 283		30	3 16 200 SG		87
16 282 SG		131	2 42 384		32	3 20 267		38
16 835 V		156	2 52 384		32	3 20 267		176
16 835 V R7		156	2 66 384		32	3 20 285		124
16 836 V		156	2 80 384		32	3 20 285 SG		124
16 836 V-1		156	20 093 V R8		156	3 25 200		91
16 836 V R7		156	20 200		91	3 25 200 SG		91
160 300/7		115	20 200 SG		91	3 25 200/7		96
160 340/7		119	20 214		155	3 25 248		188
			20 214 SG		154	3 25 248 SG		188
			20 214 SV		155	3 25 267		38
			20 215		160	3 25 267		176
			20 215		163	3 25 267 SG		38
			20 215 SG		160	3 25 267 SG		176
			20 215 SG		163	3 25 294 SG		101
			20 250 331		26	3 30 291		133
			20 261		138	3 32 268		42
			20 261 SG		138	3 35 200/7		107
			20 261-3		140	3 35 249		191
			20 261-3 SG		140	3 35 251		48
			20 275		150	3 35 251		194
			20 281		128	3 35 291		133
			20 281 SG		128	3 36 12 166 G		36
			20 282		131	3 36 12 166 G		168
			20 282 SG		131	3 40 20 167 G		38
			20 294		101	3 40 20 167 G		176
			20 835 V		156	3 40 20 185 G		124
			20 836 V		156	3 50 25 167 G		38
			20 836 V R8		156	3 50 25 167 G		176
			24 200		107	30 10 114		155
			25 261		138	30 12 100		84
			25 261 SG		138	30 15 100		77
			25 261-3		140	30 281		129
			25 261-3 SG		140	30 282		131
			25 275		150	30 294		101
			25 281		128	32 200		115
			25 281 SG		128	32 260		146
			25 282		131	32 260-90		144
			25 282 SG		131	32 261		138
			25 294		101	32 261-3		140

Part no.	3	Page
32 275		150
35 200		107
35 201		115
35 281		128
35 282		131
35 294		101

Part no.	4	Page
4 16 266		36
4 16 266		168
4 16 266 SG		36
4 16 266 SG		168
4 20 200		87
4 20 200 SG		87
4 20 235		84
4 25 200		91
4 25 267		38
4 25 267		176
4 25 285		124
4 25 285 SG		124
4 30 200		91
4 30 201		91
4 30 248		188
4 30 285		124
4 32 248		188
4 32 267		38
4 32 267		176
4 35 200		107
4 35 200/7		107
4 35 248		188
4 40 268		42
4 40 331		26
4 40 351		48
4 40 351		194
4 40 368		42
4 42 249		191
4 42 268		42
4 42 291		133
4 42 310		107
4 42 349		191
4 42 351		48
4 42 351 RF		194
4 42 368		42

Part no.	4	Page
4 48 16 166 G		36
4 48 16 166 G		168
4 50 25 167 G		38
4 50 25 167 G		176
4 50 351		48
4 50 351		194
40 10 115 G		161
40 10 115 G		164
40 12 100		85
40 15 100		87
40 20 100		91
40 200		119
42 200		107
42 260		146
42 260-90		144
42 261		138
42 261-3		140
42 281		128
42 310/7 HL		103
42 360		146
42 360-90		144
48 12 115 G		161
48 12 115 G		164

Part no.	5	Page
5 20 266		36
5 20 266		168
5 20 266 SG		36
5 20 266 SG		168
5 25 200		87
5 25 200 SG		87
5 25 235		84
5 25 235 SG		84
5 25 266		36
5 25 266		168
5 25 266 SG		36
5 25 266 SG		168
5 30 200		87
5 32 267		38
5 32 267		176
5 32 285		124
5 35 200		91

Part no.	5	Page
5 35 200/7		96
5 35 248		188
5 35 285		124
5 42 200		107
5 42 248		188
5 42 267		38
5 42 267		176
5 42 310		107
5 42 310/7		108
5 42 348		188
5 42 367		39
5 42 367		177
5 50 331		26
5 50 351		48
5 50 351		194
5 50 351 RF		48
5 50 351 RF		194
5 50 368		42
5 52 300/7		115
5 52 300/7 VD		115
5 52 349		191
5 52 351		48
5 52 351		194
5 52 351 RF		48
5 52 351 RF		194
5 52 368		42
5 52 391		133
5 66 340/7		119
50 08 114		155
50 12 114		155
52 300		115
52 300/7 HL		112
52 310		107
52 310/7		108
52 310/7 HL		103
52 360		146
52 360-90		144

Item number index

Part no.	6	Page
----------	---	------

6 35 200		87
6 42 200		91
6 42 200/7		96
6 42 285		124
6 42 310		92
6 42 310/7		96
6 42 310/7 VD		96
6 52 348		188
6 52 367		39
6 52 367		177
6 63 331		26
6 63 351		48
6 63 351		194
6 63 351 RF		48
6 63 351 RF		194
6 63 368		42
6 66 300/7		115
6 66 351		48
6 66 351		194
6 66 351 RF		48
6 66 351 RF		194
6 66 368		42
6 66 391		133
6 80 351		48
6 80 351		194
6 80 351 RF		194
60 12 100		85
60 15 100		87
60 16 114		155
60 20 100		91
64 16 115 G		161
64 16 115 G		164
66 300		115
66 300/7		115
66 300/7 HL		112
66 300/7 VD		115
66 310/7		108
66 310/7 HL		103
66 360		146
66 360-90		144

Part no.	7	Page
----------	---	------

7 100 351		48
7 100 351		194
7 32 266		36
7 32 266		168
7 42 200		87
7 52 310/7		96
7 52 310/7 VD		96
7 66 349		191
7 80 368		42
7 80 391		133

Part no.	8	Page
----------	---	------

8 80 331		26
8 80 349		191
8 80 351		48
8 80 351		194
8 80 351 RF		194
80 12 100		85
80 15 100		87
80 20 100		91
80 20 114		155
80 20 115 G		161
80 20 115 G		164
80 300		115
80 300/7		115
80 300/7 HL		112
80 300/7 VD		115
80 310/7		108
80 310/7 HL		103
80 340/7		119
80 360		146
80 360-90		144

Part no.	9	Page
----------	---	------

9 100 351		48
9 100 351		194
9 100 368		42

Part no.	A-Z	Page
----------	-----	------

DR07-016-E08-02		65
DR07-020-E10-05		65
DR07-025-E12-06		65
DR07-030-E12-07		65
DR07-035-E16-08		65
DR07-8B3		66
DR07-8B7		66
DR07-8C4		66
DR07-8E4		66
DR07-8F4		66
DR1 6-8E4		77
DR10-020-E10-02		68
DR10-025-E12-03		68
DR10-025-E12-04		68
DR10-030-E12-04		68
DR10-030-E16-04		68
DR10-032-E16-04		68
DR10-032-E16-05		68
DR10-035-E16-05		68
DR10-035-E16-06		68
DR10-040-A16-05		68
DR10-042-A16-05		68
DR10-042-A16-06		68
DR10-042-E16-06		68
DR10-050-A22-07		68
DR10-052-A22-07		68

Part no.	A-Z	Page	Part no.	A-Z	Page	Part no.	A-Z	Page
DR10-052-A22-08		68	DR16-100-A32-08		76	N 5 42 200		91
DR10-80B7		69	DR16-125-A40-09		76	SQ09-016-E10-03-45		58
DR10-8B3		69	DR16-8B3		77	SQ09-016-Z16-03-32-45		58
DR10-8B7		69	DR16-8B7		77	SQ09-020-E12-03-45		58
DR10-8C4		69	DR16-8C4		77	SQ09-020-Z20-03-40-45		58
DR10-8E4		69	DR16-8E4		77	SQ09-025-E12-04-45		58
DR10-8F4		69	DR16-8F4		77	SQ09-025-Z25-04-50-45		58
DR12-024-E12-02		72	DR20-100-A32-07-L		80	SQ09-025-Z25-03-50-90		57
DR12-032-E16-04		72	DR20-125-A40-08-L		80	SQ09-025-E12-03-90		57
DR12-035-E16-03		72	DR20-160-A40-10-L		80	SQ09-032-E16-04-90		57
DR12-035-E16-04		72	DR20-8C4-L		80	SQ09-035-E16-04-90		57
DR12-035-E16-05		72	DR20-8F4-L		80	SQ09-035-E16-05-45		58
DR12-040-A16-05		72	FR05-016-D10-03		182	SQ09-040-E16-05-90		57
DR12-040-A16-06		72	FR05-016-E08-02		182	SQ09-040-A16-05-90		57
DR12-042-A16-05		72	FR05-016-E08-03		182	SQ09-040-A16-06-45		58
DR12-050-A22-06		72	FR05-016-Z16-03-32		182	SQ09-042-E16-05-90		57
DR12-050-A22-07		72	FR05-020-D12-04		182	SQ09-042-A16-05-90		57
DR12-052-A22-06		72	FR05-020-E10-04		182	SQ09-050-A22-06-90		57
DR12-052-A22-07		72	FR05-020-Z20-04-40		182	SQ09-050-A22-07-45		58
DR12-063-A27-06		72	FR05-025-D16-05		182	SQ09-052-A22-06-90		57
DR12-066-A27-07		72	FR05-025-E12-05		182	SQ09-063-A27-07-90		57
DR12-066-A27-08		72	FR05-032-E16-05		182	SQ09-063-A27-08-45		58
DR12-066-A27-09		72	FR05-035-E16-06		182	SQ09-066-A27-07-90		57
DR12-080-A27-08		72	FR05-042-E16-06		182	SQ09-8020-R08-MN		59
DR12-080-A27-09		72	FR05-8242-HF-MP		183	SQ09-8048-R08-MP		59
DR12-080-A27-10		72	FR05-8242-HF-RP		183	SQ09-8062-R08-MK		59
DR12-100-A32-10		72	FR05-8048-HF-RP		183	SQ09-8096-R08-MM		59
DR12-80B7		73	FR05-8062-HF-RK		183	SQ09-8099-R08-MS		59
DR12-8B3		73	FR05-8096-HF-MM		183	VF09-016-D10-02-R+		52
DR12-8B7		73	HP06-016-E08-02		172	VF09-016-E08-02-R+		52
DR12-8C4		73	HP06-020-E10-03		172	VF09-020-D12-03-R+		52
DR12-8E4		73	HP06-025-E12-03		172	VF09-020-E10-03-R+		52
DR12-8F4		73	HP06-025-E12-04		172	VF09-025-D16-04-R+		52
DR16-032-E16-02		76	HP06-032-E16-04		172	VF09-025-E12-04-R+		52
DR16-040-E16-04		76	HP06-032-E16-05		172	VF09-032-E16-05-R+		52
DR16-052-A22-05		76	HP06-035-E16-05		172	VF09-035-E16-06-R+		52
DR16-052-A22-06		76	HP06-042-A16-05		172	VF09-042-E16-07-R+		52
DR16-063-A27-06		76	HP06-042-A16-07		172	VF09-8035-R08-LH-2		52
DR16-066-A27-06		76	HP06-052-A22-05		172	VF09-8035-R20-LH-2		52
DR16-080-A27-07		76	HP06-052-A22-07		172			

Notes

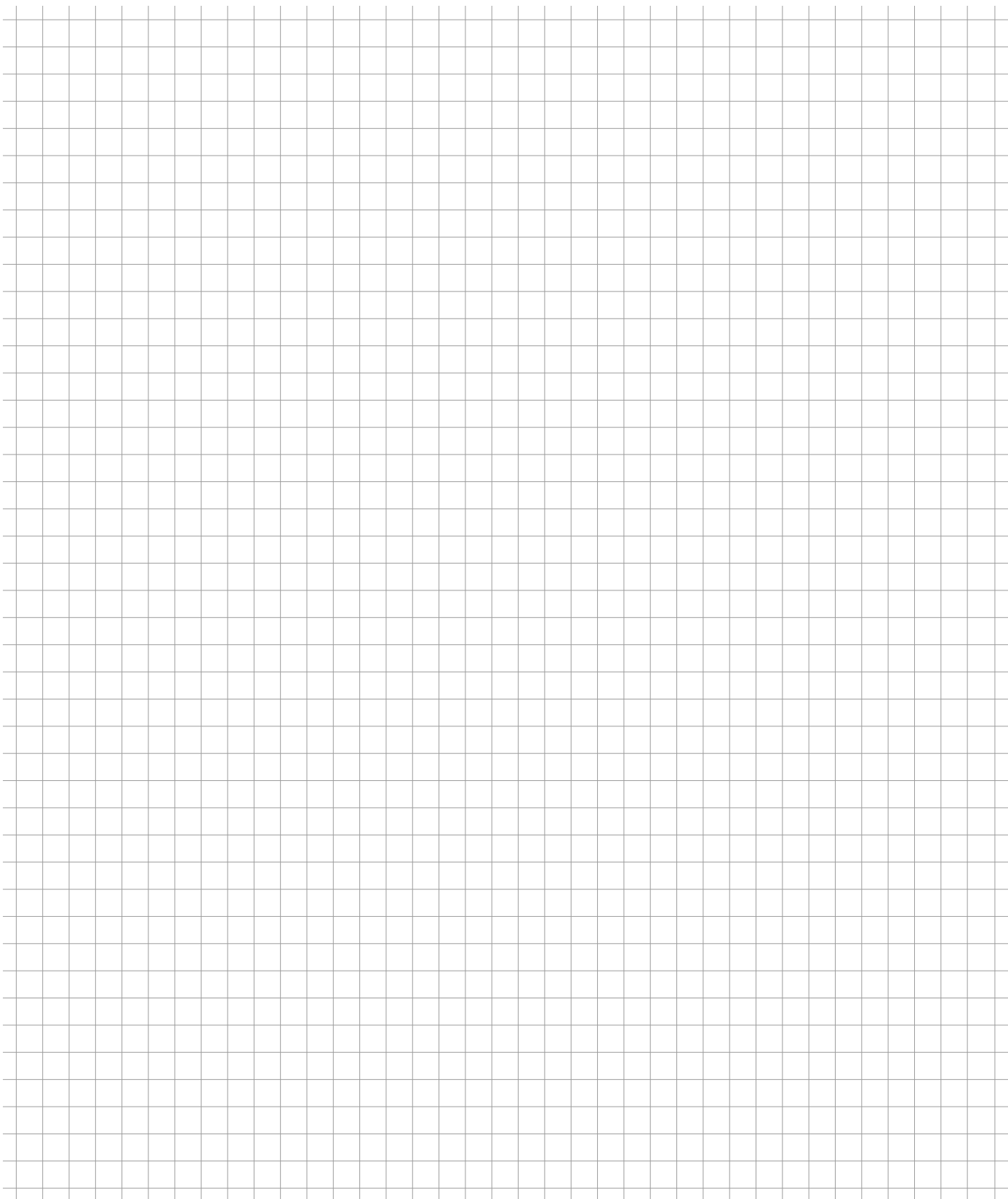
A large grid of graph paper for taking notes, consisting of 20 columns and 30 rows of small squares.

Notes

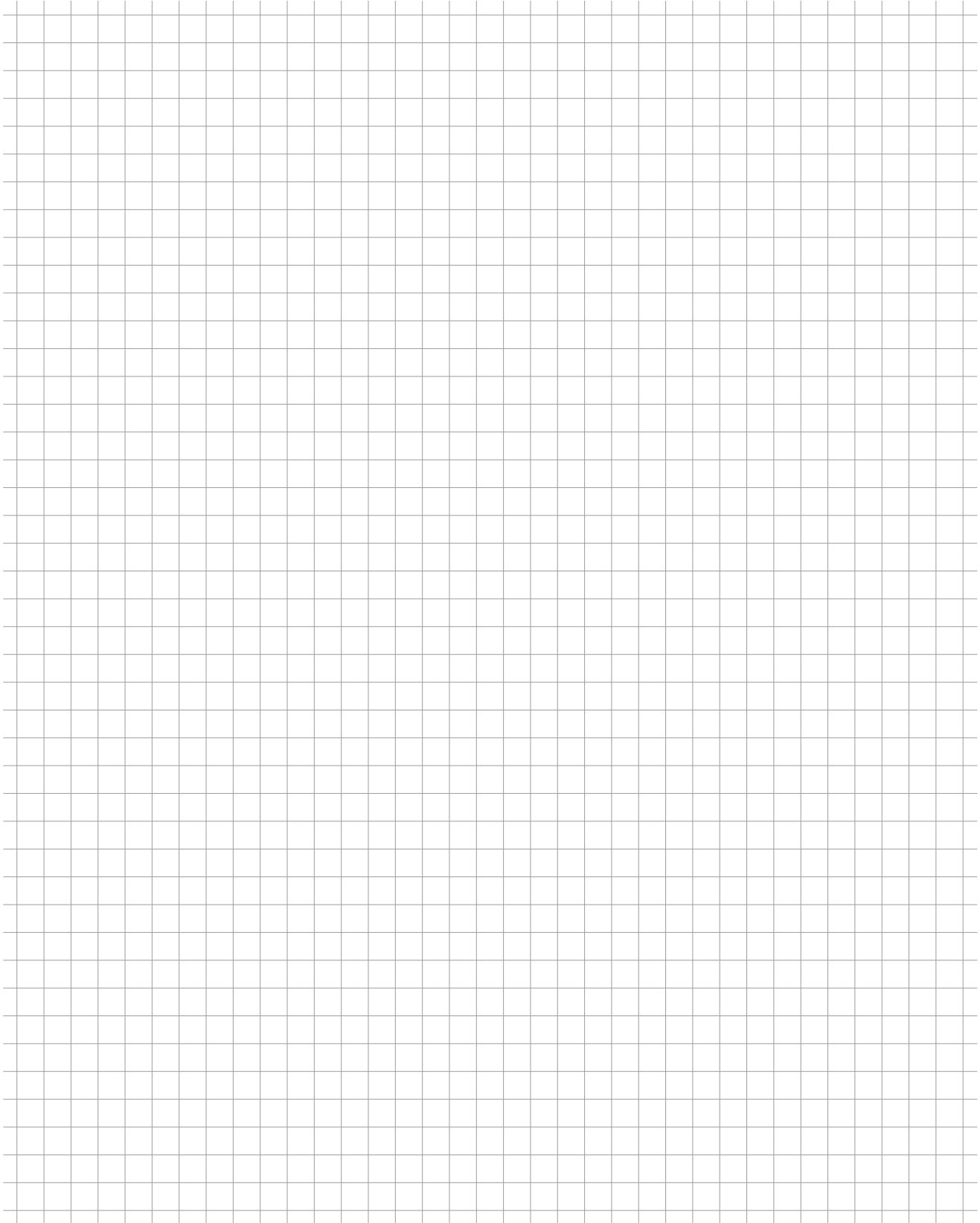

Notes

A large grid of graph paper for taking notes, consisting of 20 columns and 30 rows of small squares.

Notes

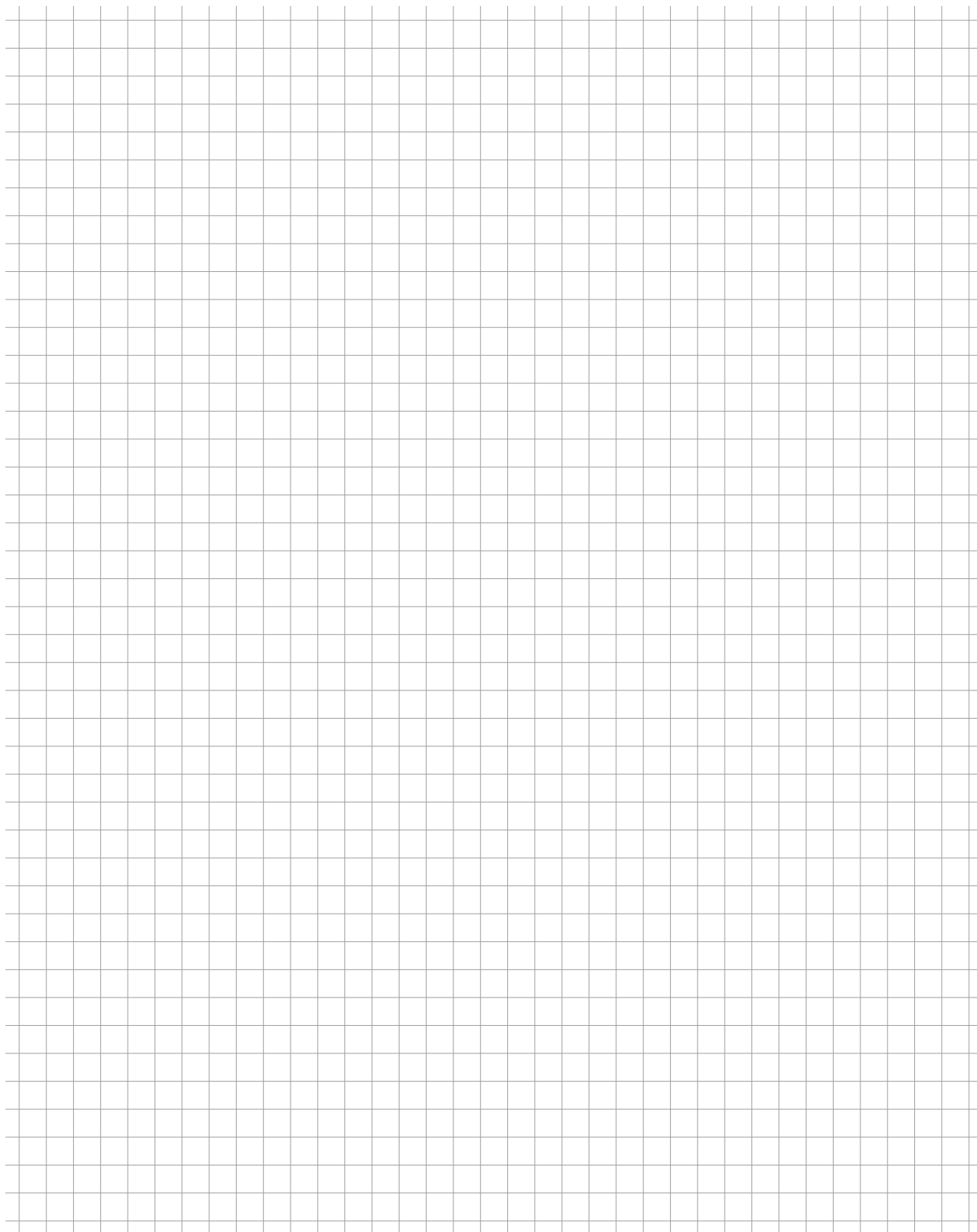

Quick finder

Fit dimensions for threaded shank end mills

Thread	M 5	M 6	M 8	M 10	M 12	M 16
Fit dimension diameter in mm	5.5	6.5	8.5	10.5	12.5	17.0
Tightening torque in Nm	7	10	15	30	50	100

Thread sizes of arbors for shell type milling cutters:

Pilot diameter in mm	16	22	27	32	40
Fastening screw	M 8	M 10	M 12	M 16	M 20

Remarks on dimensions d_4 and l_3 for arbors

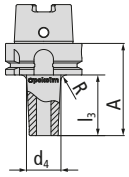

Dimensions d_4 and l_3 for arbors (see left diagram) are calculated up to the theoretical intersection between the arbor cone and arbor collar.

Please take the transition radius R (5-8 mm depending on arbor type) into account for the practical application.

Theoretical usable length with solid carbide shanks*:

	Shank diameter (DIN 6535) $d_2 h_5$	2 - 5	6 + 8	10	12 + 14	16 + 18
	DIN length of shank (DIN 6535) l_{2-0}^{+2}	28	36	40	45	48
	Shank diameter (DIN 6535) $d_2 h_5$	20	25	32 + 36-	-	-
	DIN length of shank (DIN 6535) l_{2-0}^{+2}	50	56	60	-	-
<p>* The usable length is determined from the total length l_1 (see catalog) of the solid carbide cutter/solid carbide arbor minus the DIN length of shank (l_2 according to DIN 6535) pursuant to the table above.</p>						

At a glance

Product features



available from stock

DIN
1835 A

DIN 1835 A

DIN
1835 B

DIN 1835 B

DIN
1830

DIN 1830

DIN
2079

DIN 2079

DIN
228 A

DIN 228 A

DIN
6499-B

DIN 6499-B

DIN
69871 AD

DIN 69871 AD

DIN
69893

DIN 69893



DuoPlug®



Embedded indexable insert

Form
A

Form A

Form
BT

Form BT

Form
E

Form E

Form
E + C

Form E+C



Suitable for HSC processing



3° positively inclined



7° positively inclined



Backing

At a glance

Product features



Internal coolant supply

JIS B
6339 AD

JIS B 6339 A



Max. speed 7000



Max. speed 6000



Zero length mount



Flange contact surface



Point cutting



Heavy metal



Toric tool

SOLID
CARBIDE

Solid carbide



Wider tooth pitch

G 2,5
40.000

Balance quality G 2.5 40,000

G 2,5
30.000

Balance quality G 2.5 30,000

G 2,5
25.000

Balance quality G 2.5 25,000

G 6,3
15.000

Balance quality G 6.3 15,000

G 6,3
18.000

Balance quality G 6.3 18,000

G 6,3
12.000

Balance quality G 6.3 12,000

G 6,3
8.000

Balance quality G 6.3 8,000

G 16
8.000

Balance quality G 16 8,000

Imprint

© 2023 Pokolm Frästechnik GmbH & Co. KG

All rights reserved. Reproduction, modification, or duplication of any kind in whole or in part are prohibited without written consent. This documentation replaces all previous versions. Dimensions and designs contained in previous documentation in digital or printed form may have changed as a result of modified standards. We reserve the explicit right to make changes based on new standards or technical advancements. Product illustrations are for clarification purposes only, and do not always correspond in every case or every detail to the actual design. Items conforming to older standards are delivered until their stocks are no longer available. No liability is accepted for any errors.

We are here for you!

If you have questions or need individual advice, our technical support team will be happy to assist you.



Service Hotline: +49 5247 9361-0

For further information, request our other catalogues:

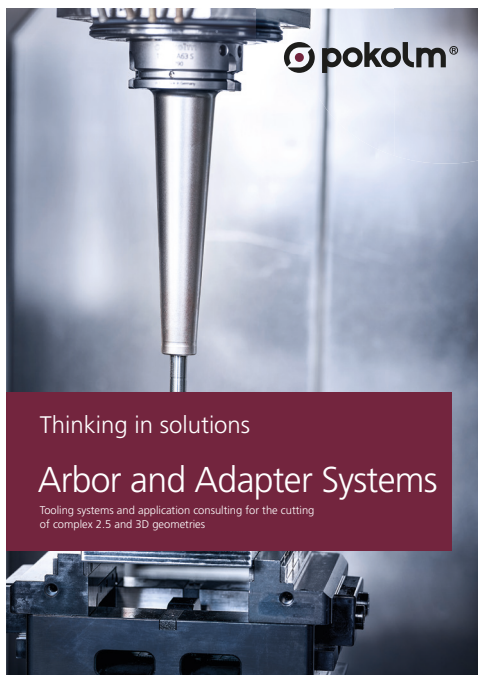

Arbor and Adapter Systems

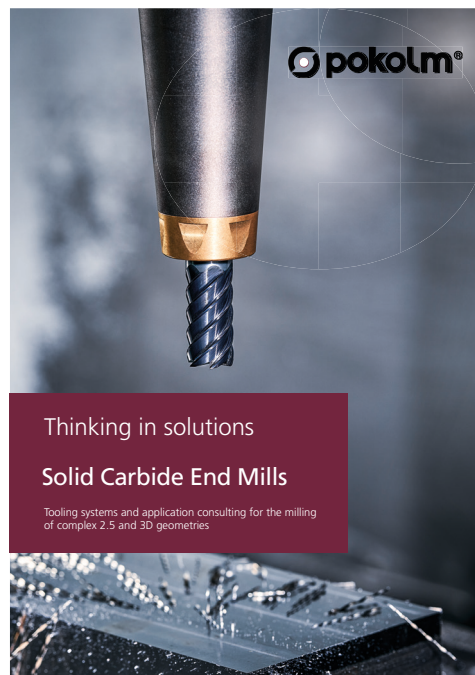

Solid Carbide End Mills

Pokolm Frästechnik GmbH & Co. KG

Adam-Opel-Straße 5
D-33428 Harsewinkel
Telephone: +49 5247 9361-0
Fax: +49 5247 9361-99

info@pokolm.de | www.pokolm.de/en



FL-344-EN



www.pokolm.de/en